

Habu 32 EDF ARF

Assembly Manual



Notice

All instructions, warranties and other collateral documents are subject to change at the sole discretion of Horizon Hobby, Inc. For up-to-date product literature, visit <http://www.horizonhobby.com> and click on the support tab for this product.

Meaning of Special Language

The following terms are used throughout the product literature to indicate various levels of potential harm when operating this product:

NOTICE: Procedures, which if not properly followed, create a possibility of physical property damage AND a little or no possibility of injury.

CAUTION: Procedures, which if not properly followed, create the probability of physical property damage AND a possibility of serious injury.

WARNING: Procedures, which if not properly followed, create the probability of property damage, collateral damage, and serious injury OR create a high probability of superficial injury.



WARNING: Read the ENTIRE instruction manual to become familiar with the features of the product before operating. Failure to operate the product correctly can result in damage to the product, personal property and cause serious injury.

This is a sophisticated hobby product and NOT a toy. It must be operated with caution and common sense and requires some basic mechanical ability. Failure to operate this Product in a safe and responsible manner could result in injury or damage to the product or other property. This product is not intended for use by children without direct adult supervision. Do not attempt disassembly, use with incompatible components or augment product in any way without the approval of Horizon Hobby, Inc. This manual contains instructions for safety, operation and maintenance. It is essential to read and follow all the instructions and warnings in the manual, prior to assembly, setup or use, in order to operate correctly and avoid damage or serious injury.



Warnings

Read and follow all instructions and safety precautions before use. Improper use can result in fire, serious injury and damage to property.

Age Recommendation: Only for advanced fliers 14 and up. This is not a toy.

COMPONENTS

Use only with compatible components. Should any compatibility questions exist please refer to the product instructions, the component instructions or contact Horizon Hobby, Inc.

FLIGHT

Fly only in open areas to ensure safety. It is recommended flying be done at AMA (Academy of Model Aeronautics) approved flying sites. Consult local laws and ordinances before choosing a location to fly your aircraft.

INTAKE/FAN

Keep loose items that can get entangled in the fan away from the intake and exhaust, including loose clothing, or other objects such as pencils and screwdrivers. Especially keep your hands away from the intake and exhaust as injury can occur.

BATTERIES



Notes on Lithium Polymer Batteries

When misused, lithium polymer batteries are significantly more volatile than alkaline or Ni-Cd/ Ni-MH batteries used in RC applications. Always follow the manufacturer's instructions when using and disposing of any batteries. Mishandling of Li-Po batteries can result in fire causing serious injury and damage.

SMALL PARTS

This kit includes small parts and should not be left unattended near children as choking and serious injury could result.

SAFETY PRECAUTIONS

- Check all control surfaces prior to each takeoff.
- Do not fly your model near spectators, parking areas or any other area that could result in injury to people or damage of property.
- Do not fly during adverse weather conditions. Poor visibility can cause disorientation and loss of control of your aircraft. Strong winds can cause similar problems.
- Do not take chances. If at any time during flight you observe any erratic or abnormal operation, land immediately and do not resume flight until the cause of the problem has been ascertained and corrected. Safety can never be taken lightly.
- Do not fly near power lines.

Table of Contents

Introduction	3
Important Information Regarding Warranty Information.....	3
Specifications.....	3
Using the Manual.....	3
Contents of Kit/Parts Layout.....	3
Covering Colors.....	4
Hardware/Accessory Sizes.....	4
Recommended Radio Equipment	4
Motor Setup.....	4
Optional Accessories.....	4
Optional Retracts	4
Optional Batteries	4
Required Tools and Adhesives.....	4
Control Horn Installation.....	5
Aileron Servo Installation.....	7
Flap Servo Installation	11
Wing Spar Installation.....	15
Main Landing Gear Installation - Fixed Gear	18
Main Landing Gear Installation - Retractable Gear	20
Optional Main Landing Gear Doors.....	24
Nose Gear Installation - Fixed Gear.....	26
Nose Gear Installation - Retracts.....	29
Rudder Servo Installation	33
Stabilizer Spar Installation	35
Elevator Servo Installation.....	38
Fan Installation.....	41
Exhaust Tube and Speed Control Installation	44
Receiver Installation - 6-channel Receiver.....	45
Receiver Installation - 8-channel Receiver.....	47
Motor Battery Installation.....	48
Canopy Assembly	49
Center of Gravity	50
Control Throws.....	50
Preflight.....	51
Flying Your Model.....	52
Range Test Your Radio.....	52
Daily Flight Checks.....	53
Warranty and Repair Policy.....	53
Warranty Services.....	54
Compliance Information for the European Union....	54
2010 Official Academy of Model Aeronautics Safety Code.....	55

Introduction

E-flite takes ARF ducted fan performance and engineering to new heights with the Habu 32 DF. Designed around the E-flite Delta-V® 32 80mm fan unit and 2150Kv DF32 brushless motor, its hyper-efficient intake and exhaust ducting allows this potent combo to produce large amounts of thrust when powered with an E-flite 6S 5000 30C Li-Po pack. And it does so without resorting to drag-inducing cheater holes. The result is a sport EDF with exhilarating speed that will give even experienced jet jockeys goose bumps.

As the first Platinum Series E-flite® ducted fan, the Habu 32 DF also boasts a level of fit and finish that is every bit as impressive as its performance. Its sleek fiberglass fuselage comes pre-painted and integrates the vertical stabilizer. The fully-sheeted wings and horizontal stabilizers are mounted with carbon blade spars and covered with genuine UltraCote® covering. The control surfaces are hinged for you. Just add the optional E-flite electric retracts (sold separately), and you've got a sport jet that truly stands out from the crowd.

Important Information Regarding Warranty Information

Please read our Warranty and Liability Limitations in the back of this manual before building this product. If you as the Purchaser or user are not prepared to accept the liability associated with the use of this Product, you are advised to return this Product immediately in new and unused condition to the place of purchase.

Specifications

Wingspan:	40.5 in (1030mm)
Wing Area:	392 sq in (25.3 sq dm)
Length:	49.3 in (1250mm)
Weight w/o Battery:	5.15–5.45 lb (2.35–2.50 kg)
Weight with Battery:	7.05–7.40 lb (3.20–3.35 kg)

Using the Manual

This manual is divided into sections to help make assembly easier to understand, and to provide breaks between each major section. In addition, check boxes have been placed next to each step to keep track of its completion. Steps with a single circle (○) are performed once, while steps with two or more circles (○○) indicate the step will require repeating, such as for a right or left wing panel, two servos, etc.

Remember to take your time and follow the directions.

Contents of Kit/Parts Layout

Replacement Parts

EFL807501	Fuselage with Hatches and Rudder
EFL807502	Main Wing Left
EFL807503	Main Wing Right
EFL807504	Horizontal Stabilizer Left and Right
EFL807505	Main Canopy Hatch
EFL807506	Plastic Accessories
EFL807507	Thrust Tube
EFL807508	Hardware
EFL807509	Pushrod Set
EFL807510	Decal Sheet
EFL807511	Landing Gear Struts
EFL807512	Fixed Gear Mounts Main
EFL807513	Fixed Nose Gear
EFLAW175	Aluminum Wheel Set 1 ³ / ₄ -inch (44.5mm) (3)



Covering Colors

HANU871	Deep Red
HANU881	Silver
HANU77	Pearl Charcoal

Hardware/Accessory Sizes

Main wheel diameter	1 ³ / ₄ -inch (44.5mm)
Nose wheel diameter	1 ³ / ₄ -inch (44.5mm)
Wing bolt	8-32 x 1/4-inch
Stabilizer bolt	3mm x 1.5mm

Recommended Radio Equipment

You will need a minimum 5-channel transmitter, receiver and eight servos. You can choose to purchase a complete radio system. If you are using an existing transmitter, just purchase the other required equipment separately. We recommend the crystal-free, interference-free Spektrum™ DX8 2.4GHz DSM® 8-channel system. If using your own transmitter, we recommend the following radio equipment.

If you own the Spektrum DX8 radio, or you are using a different DSM2 radio, just add the AR8000 DSM2™ 8-channel receiver and seven JR SPORT™ MC35 servos and one JR DS368 servo.

Complete Radio System

SPM8800	DX8 DSM2 8CH system
---------	---------------------

8-channel receiver installation:

SPMAR8000	AR8000 DSM2 8-Channel Full-Range Receiver
JSP20030	MC35 Servo (7)
JRPSDS368	DS368 Premium Digital Servo, rudder
SPMA3050	3-inch (76mm) Servo Extension (5)
SPMA3051	6-inch (152mm) Servo Extension
SPMA3052	9-inch (228mm) Servo Extension
SPMA3053	12-inch (305mm) Servo Extension
SPMA3004	18-inch (457mm) Servo Extension (3)
SPMA3058	Y-Harness (2)

Note: The extensions listed for the 8-channel operation (separate ailerons and nose gear) will require the use of mixing at the transmitter.

6-channel receiver installation:

SPMAR6200	AR6200 DSM2 6-Channel Full-Range Receiver
JSP20030	MC35 Servo (7)
JRPSDS368	DS368 Premium Digital Servo, Rudder
SPMA3050	3-inch (76mm) Servo Extension (5)
SPMA3051	6-inch (152mm) Servo Extension
SPMA3052	9-inch (228mm) Servo Extension
SPMA3053	12-inch (305mm) Servo Extension (2)
SPMA3004	18-inch (457mm) Servo Extension
SPMA3058	Y-Harness (3)
EFLRYH3	3-inch (76mm) Y-Harness, Lightweight

Note: The extensions listed for the 6-channel operation will require surfaces (flaps, ailerons and steering-to-rudder) to be Y-harnessed.

Motor Setup

EFLM3032DFA	DF32 Brushless Motor, 2150Kv
EFLDF32	Delta-V 32 80mm EDF
EFLA1080	80-Amp Pro SB Brushless ESC
EFLB50006S30	5000mAh 6S 22.2V 30C Li-Po, 10AWG EC5

Optional Accessories

EFLC3020	Celectra™ 200W DC Multi-Chemistry Battery Charger
EFLA110	Power Meter
EFLAEC312	Charge Lead with 12-inch Wire and Jacks, 16AWG
PKZ4414	Pilot

Optional Retracts

EFLG230	15-25 Tricycle Electric Retracts
---------	----------------------------------

Optional Batteries

EFLB50006S50C	5000mAh 6S 22.2V 50C Li-Po, 10AWG EC5
THP50006SP45	5000mAh 6-Cell/6S 22.2V G4 Pro Power 45C Li-Po

Required Tools and Adhesives

Tools & Equipment

Balancing stand	Clear tape
Drill	Epoxy brush
Felt-tipped pen	Flat file
Glass cleaner	Hemostats
Hobby scissors	Low-tack tape
Mixing cup	Mixing stick
Paper towels	Pencil
Petroleum jelly	Phillips screwdriver: #0, #1
Pin vise	Pliers
Rotary tool	Rubbing alcohol
Ruler	Sanding block
Sanding drum	Scissors
Side cutter	Square
String	Triangle
Trim seal tool	
Ball driver: 2.5mm, 9/64-inch	
Drill bit: 1/16-inch (1.5mm), 5/64-inch (2mm)	
Hex wrench: 1.5mm, 2.5mm	
Hobby knife with #11 blade	
Medium grit sandpaper	

Adhesives

5-minute epoxy	PAAPT38
15-minute epoxy	MEUEPX15MIN
CA accelerator	PAAPT715
Canopy glue	PAAPT56
Medium CA	PAAPT02
Thin CA	PAAPT08
Threadlock	PAAPT42

E-tips

During the course of building your model we suggest you use a soft base for the building surface.

Such things as a foam stand, large piece of bedding foam or a thick bath towel will work well and help protect the model from damage during assembly. This is not shown in the instructions to provide the greatest detail in the photos.

E-tips

When referencing directions (up, down, left, right top and bottom) these directions are in relationship to the pilot sitting in the cockpit of the aircraft unless noted otherwise.

Control Horn Installation

Required Parts

Fuselage Wing panel (right and left)
Stabilizer (right and left)
Fiberglass control horn (7)

Required Tools and Adhesives

Felt-tipped pen 5-minute epoxy
Mixing stick Mixing cup
Low-tack tape Medium grit sandpaper

E-tips

We used low-tack tape to tape the aileron at the tip and to tape the flap to the aileron so they don't move during the control horn installation.

- 1. Check the fit of the fiberglass control horn in the slot in the aileron. The hole in the control horn will align with the hinge line, and the horn will fit flush in the hole. Use a felt-tipped pen to mark the front and rear edge of the control horn on the aileron.

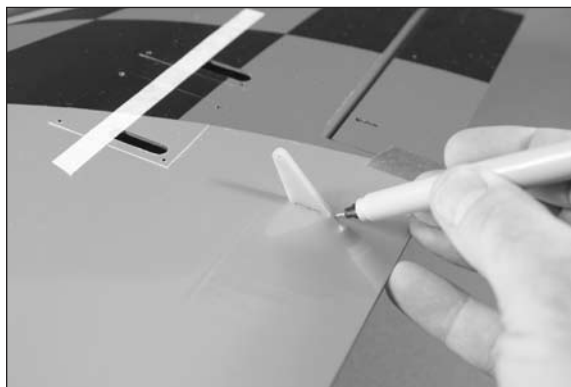

- 2. Apply low-tack tape around the opening for the flap and aileron control horn. Position the tape so it is 1/32-inch (1mm) away from the sides of the hole, as well as from the marks made in the previous step.

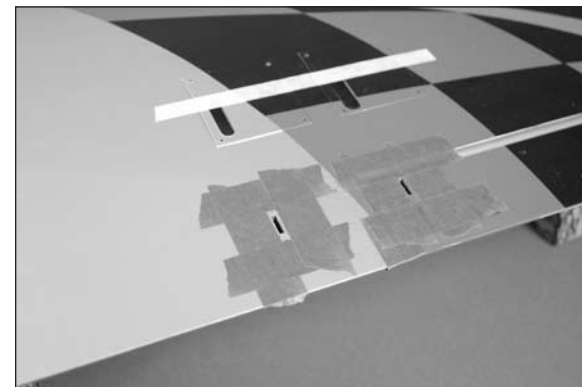

- 3. Use medium grit sandpaper to lightly sand the control horns where they fit into the openings in the flap and aileron.

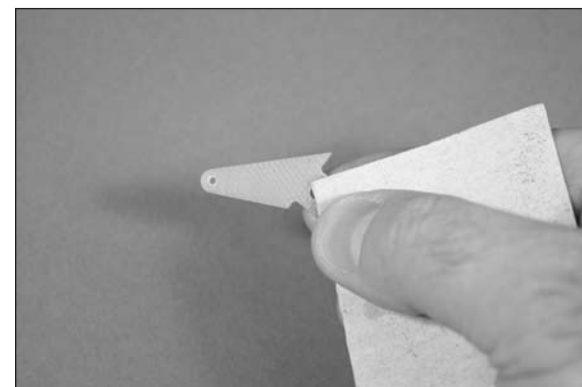

- ○ ○ ○ ○ ○ ○ ○ 4. Use 5-minute epoxy to glue the control horns into the holes for the flap and aileron. Use a square to make sure the control horn is perpendicular to the control surface. Also check again to make sure the hole in the control horn is directly over the hinge line.

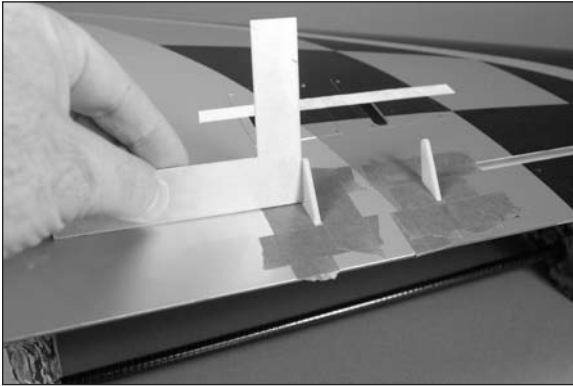

- ○ ○ ○ ○ ○ ○ ○ 5. After around 3 minutes, before the epoxy cures, carefully remove the tape from around the control horns. Pull the tape away from the horn, being careful not to disturb the position of the control horn. This will allow the epoxy to flow out slightly, leaving a fillet between the control horn and control surface.

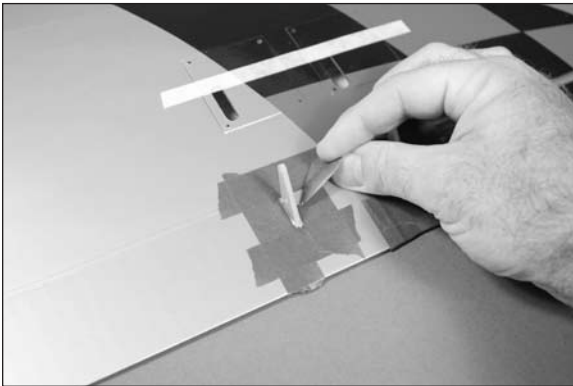

- ○ ○ ○ 6. Repeat Steps 1 through 5 to install the remaining aileron and flap control horn.

- ○ 7. Sand a slight angle on the fiberglass control horn for the elevator. This is so the top of the horn does not distort the covering on the top of the elevator. Test fit the fiberglass control horn in the slot in the elevator, making sure the horn does not distort the covering on the top of the elevator.

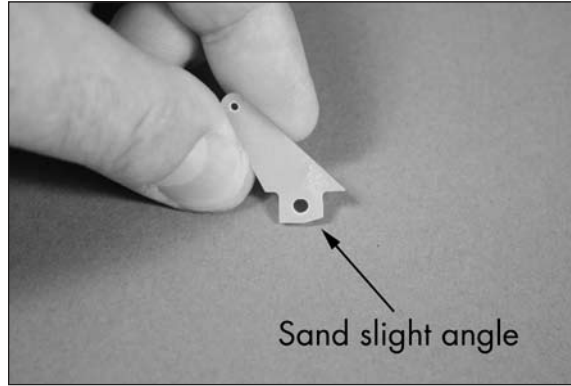

- 8. Repeat steps 1 through 5 to glue the control horns in both elevator halves.

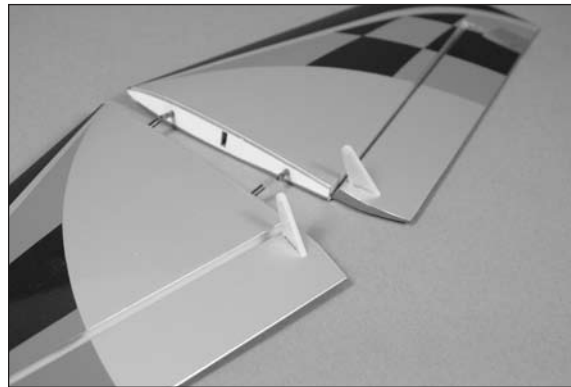

- 9. Repeat steps 1 through 5 to glue the control horn in the rudder.

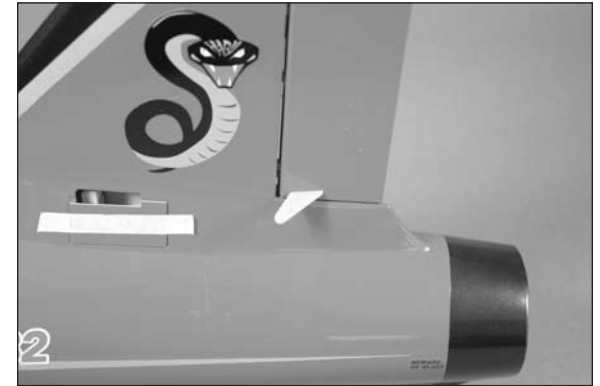

Aileron Servo Installation

Required Parts

Wing panel (right and left)	
Transmitter	Receiver
Receiver battery	Silicone tubing
Metal clevis (4)	2mm nut (4)
Servo with hardware (MC35) (2)	
Servo extension, 3-inch (76mm) (2)	
Threaded rod, 2mm x 25mm(2)	
Hardwood block, 13mm x 10mm x 7mm (4)	
2mm x 8mm self-tapping screw (8)	

Required Tools and Adhesives

Ruler	Phillips screwdriver: #1
Scissors	Hobby knife with #11 blade
String	Pencil
Thin CA	5-minute epoxy
Mixing cup	Mixing stick
Drill	Drill bit: 5/64-inch (2mm)
Rotary tool	Sanding drum
Medium grit sandpaper	

E-tips

Before starting the installation of the servos, we recommend centering the trims and sticks on your transmitter. If using a computer radio, make sure to reset a model memory and name it for this particular model. We also recommend binding the transmitter and receiver at this time following the instructions provided with your radio system.

1. Prepare the aileron servo by installing the rubber grommets and brass eyelets as shown in the radio or servo instructions. Center the aileron servo using the radio system. Use side cutters to remove any arms from the horn that may interfere with the operation of the servo.

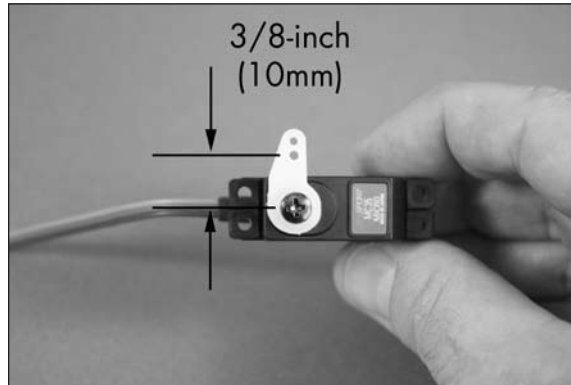

E-tips

The aileron linkage will be connected to the hole in the servo horn 3/8-inch (10mm) from the center of the arm as illustrated in the photo above.

2. Secure a 3-inch (76mm) servo extension to the aileron servo lead using string or a commercially available connector.

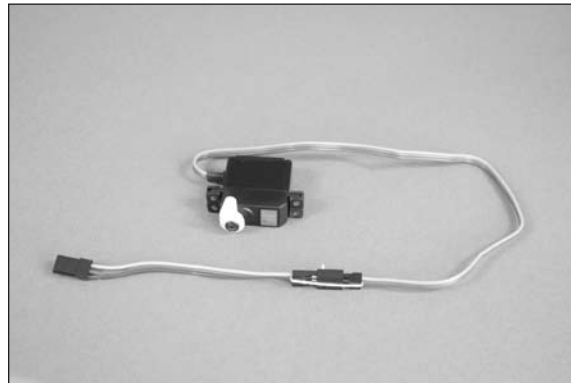

3. Repeat steps 1 and 2 to prepare a second aileron servo. Note the servos will be mirror images of each other.

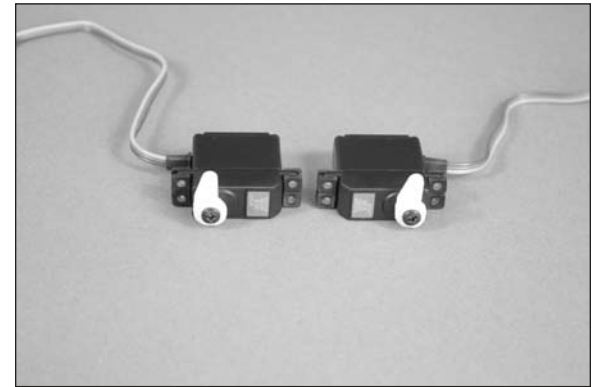

4. Remove the cover from the wing for the flap and aileron servos. Set the cover aside for the flap servo at this time.

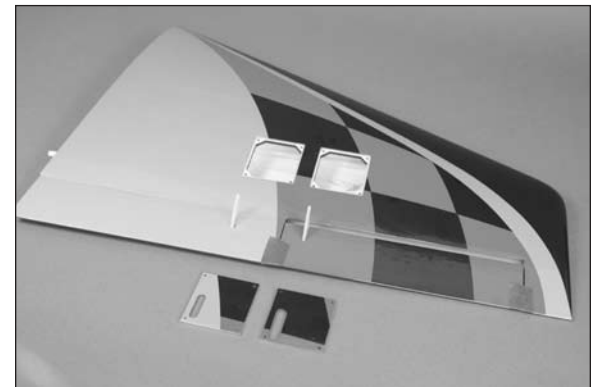

- 5. Use a pencil to draw two lines on the cover. The first line is along the bottom of the cover, $3/32$ -inch (2.5mm) from the edge. The second line is $7/8$ -inch (22mm) from the side of the cover as shown. This will center the servo horn in the slot when using the recommended servos.

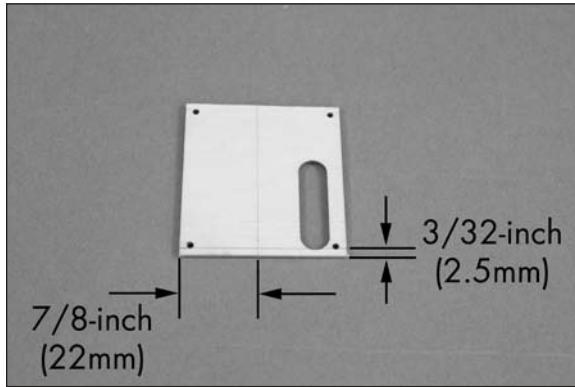

- 6. Sand the 10mm x 7mm end of the block using medium grit sandpaper. This will be the end glued to the plate in the next step.

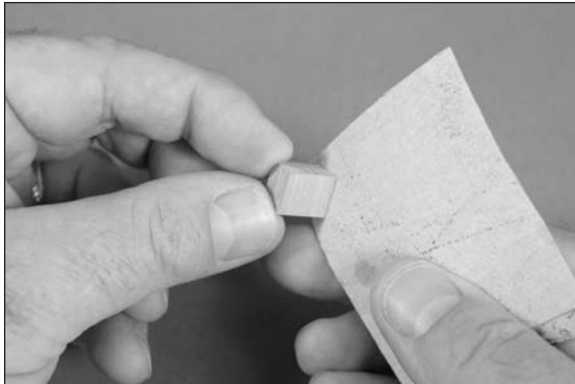

- 7. Use 5-minute epoxy to glue the 13mm x 10mm x 7mm hardwood block to the servo cover. Make sure to glue the 10mm x 7mm end to the surface of the plate. Allow the epoxy to fully cure before proceeding.

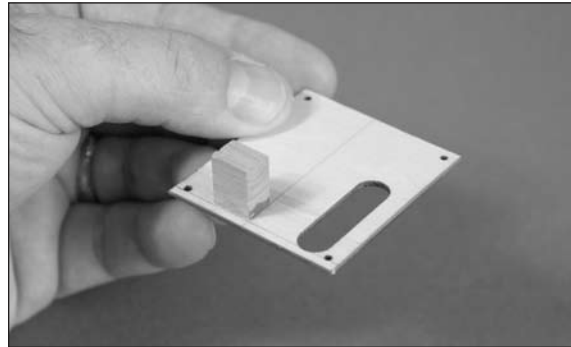

- 8. Use a rotary tool and small sanding drum to make a notch in the block for the servo lead. Check the fit of the servo to make sure the servo lead can clear the mounting block.

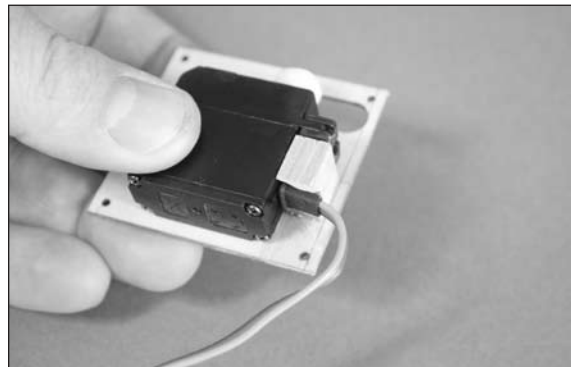
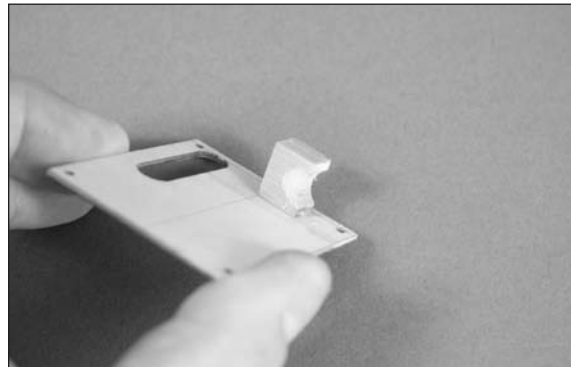

- 9. Position the aileron servo with the grommets resting on the first mounting block and the servo parallel to the line on the cover. Use a pencil to mark the location for the remaining servo mounting block.

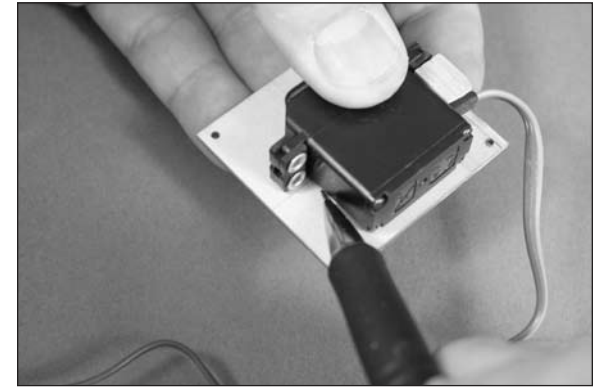

- 10. Use 5-minute epoxy to glue the remaining block to the cover. Don't forget to roughen the end of the block as shown in step 6.

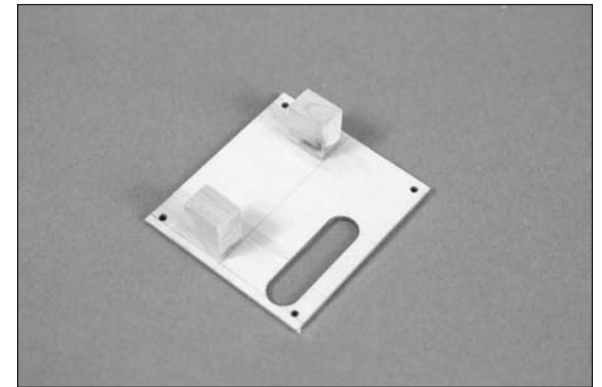

- 11. Position the servo between the two blocks. Leave a small gap between the servo and servo cover so vibrations from the airframe are not transferred directly into the servo. Use a pencil to mark the locations for the four servo mounting screws on the blocks.

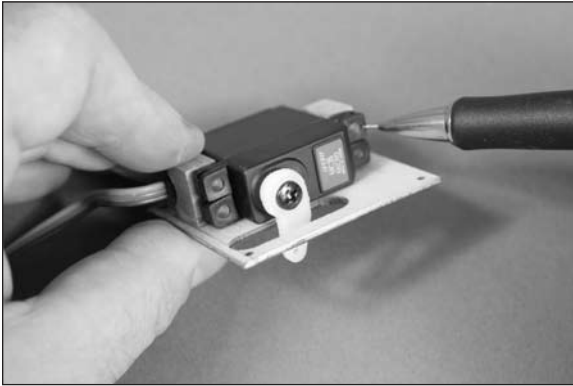

- 12. Use a drill and 5/64-inch (2mm) drill bit to drill the holes for the mounting screws. Use care not to enlarge the holes any larger than the drill bit.

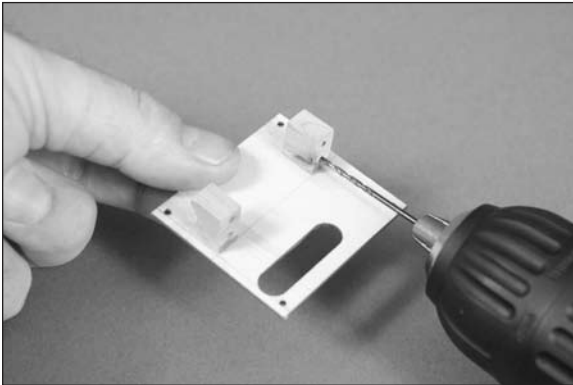

- 13. Apply 2–3 drops of thin CA in each hole drilled. Also saturate the front and rear of the block using thin CA to harden the block. This will help keep the block from splitting when the servo mounting screws are installed.

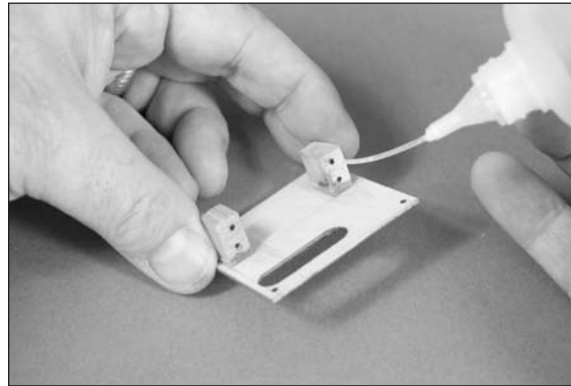
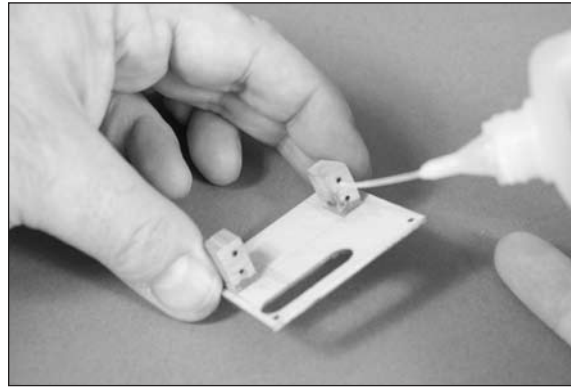

E-tips

Do not use a CA accelerator. Using an accelerator will not allow the CA to soak into the fibers of the wood, hardening the blocks.

- 14. Use the screws provided with the servo and a #1 Phillips screwdriver to attach the servo to the mounting blocks.

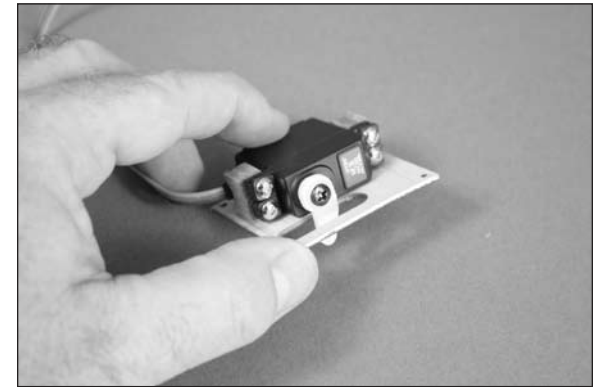

- 15. Apply 2–3 drops of thin CA in each of the aileron servo cover mounting holes. This will harden the surrounding wood, making the screws more secure when they are installed.

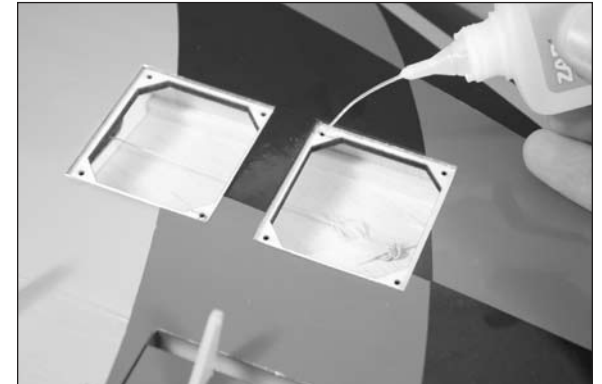

- ○ 16. Tie the end of the string around the end of the aileron servo lead. Use the string to pull the aileron servo lead into the flap servo bay.

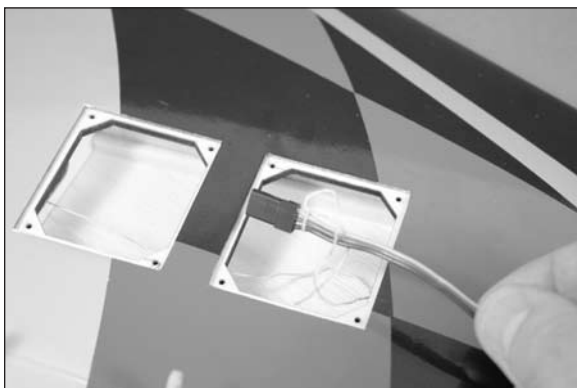

- ○ 17. Use four 2mm x 8mm self-tapping screws and a #1 Phillips screwdriver to secure the aileron servo cover to the wing.



- ○ 18. Use a hobby knife with a #11 blade to trim two 1/4-inch (6mm) pieces from the silicone tubing.



E-tips

Always use threadlock on metal-to-metal fasteners to prevent them from vibrating loose.

- ○ 19. Assemble the aileron linkage using the two pieces of tubing from the previous step, two 2mm nuts, two metal clevises and the 2mm x 25mm threaded rod. The length of the rod will be adjusted in the following steps.

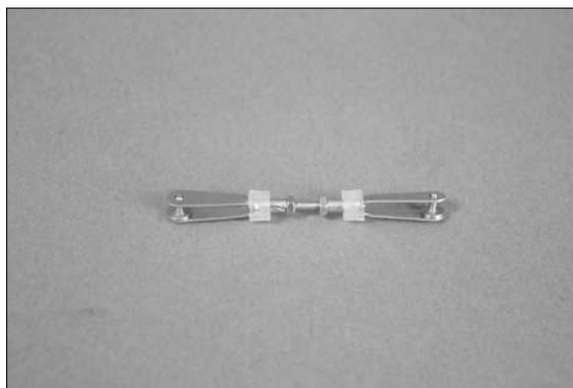

- ○ 20. Remove the tape holding the flap and aileron in position. Use the radio system to center the aileron servo. Connect the metal clevis to the inner hole of aileron servo horn. The remaining clevis connects to the aileron control horn. Adjust the length of the linkage so the aileron is centered when the servo is centered. Once the length of the linkage has been adjusted, slide the tubing over the forks of the clevises to keep them from accidentally opening in flight. Use needle nose pliers to tighten the nuts against the metal clevises.

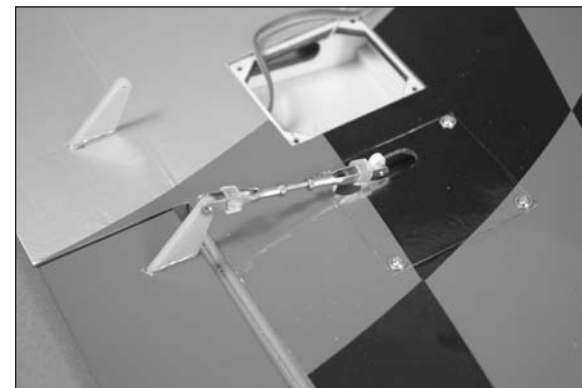

- ○ 21. Repeat steps 4 through 20 to install the remaining aileron servo and linkage.

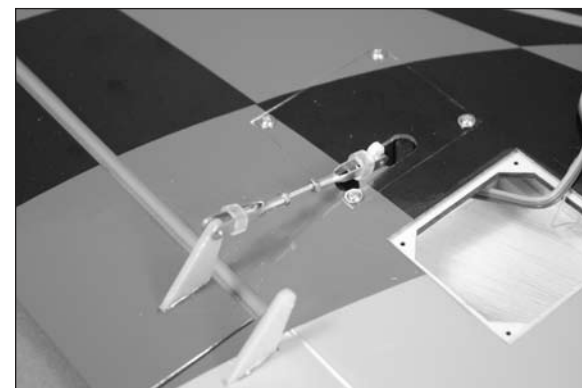

Flap Servo Installation

Required Parts

Wing panel (right and left)	
Transmitter	Receiver
Receiver battery	Silicone tubing
Metal clevis (4)	2mm nut (4)
Servo with hardware (MC35) (2)	
Threaded rod, 2mm x 25mm (2)	
Hardwood block, 13mm x 10mm x 7mm (4)	
2mm x 8mm self-tapping screw (8)	

Required Tools and Adhesives

Ruler	Phillips screwdriver: #1
Scissors	Hobby knife with #11 blade
String	Pencil
Thin CA	5-minute epoxy
Mixing cup	Mixing stick
Drill	Drill bit: 5/64-inch (2mm)
Low-tack tape	Rotary tool
Sanding drum	

E-tips

When centering the flap servo, begin by setting the throws at the transmitter to 0% for both the up and down flap positions. This is done for both 2- and 3-position flap switches.

- 1. Prepare the flap servo by installing the rubber grommets and brass eyelets as shown in the radio or servo instructions. Center the flap servo using the radio system. Use side cutters to remove any arms from the horn that may interfere with the operation of the servo.

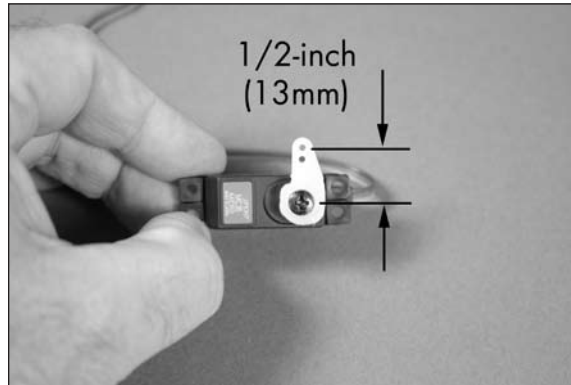

E-tips

The flap linkage will be connected to the hole in the servo horn 1/2-inch (13mm) from the center of the arm as illustrated in the photo above.

- 2. Repeat step 1 to prepare a second flap servo. Note the servos will be identical.

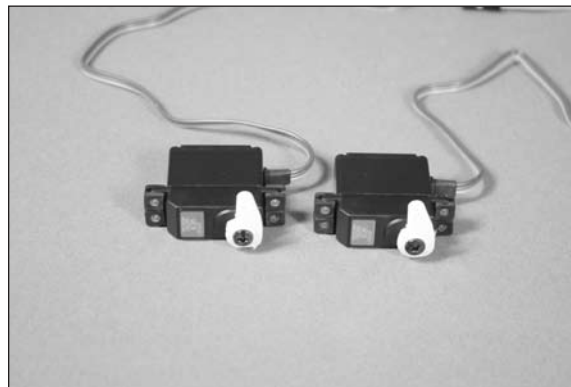

- 3. Use a pencil to draw two lines on the cover. The first line is along the bottom of the cover, 3/32-inch (2.5mm) from the edge. The second line is 7/8-inch (22mm) from the side of the cover as shown. This will center the servo horn in the slot when using the recommended servos.

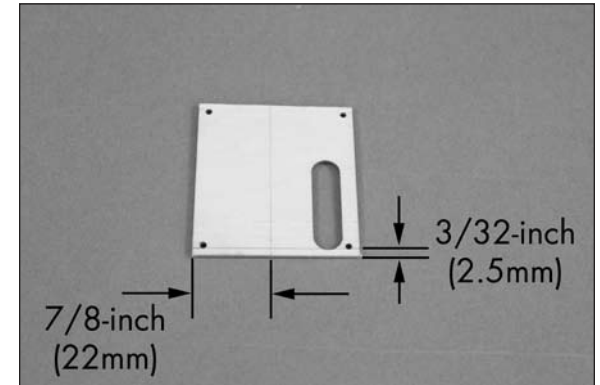

- 4. Sand the 10mm x 7mm end of the block using medium grit sandpaper. This will be the end glued to the plate in the following step.

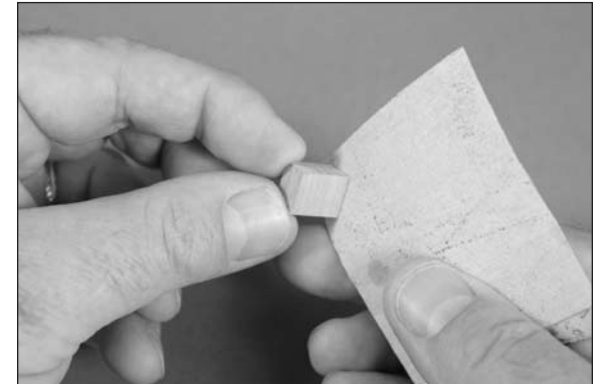

- ○ 5. Use 5-minute epoxy to glue the 13mm x 10mm x 7mm hardwood block to the servo cover. Make sure to glue the 10mm x 7mm end to the surface of the plate. Allow the epoxy to fully cure before proceeding.

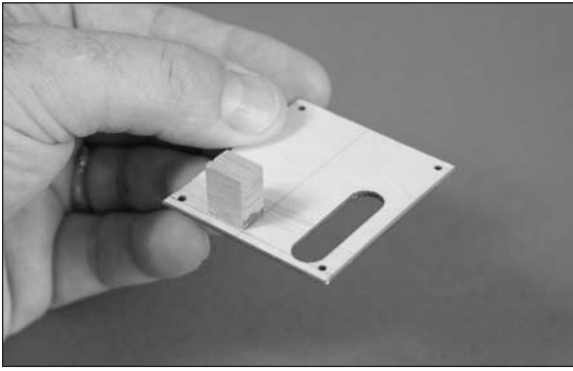

- ○ 6. Use a rotary tool and small sanding drum to make a notch in the block for the servo lead. Check the fit of the servo to make sure the servo lead can clear the mounting block.

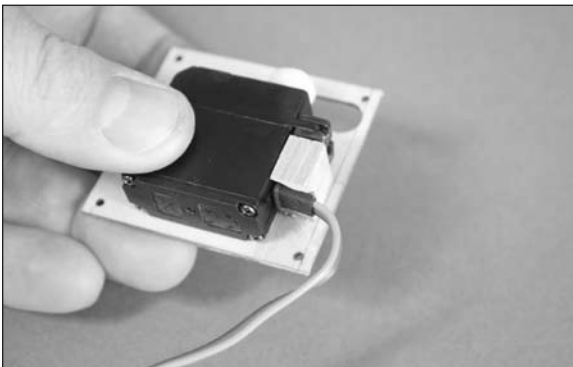

- ○ 7. Position the flap servo with the grommets resting on the first mounting block and the servo parallel to the line on the cover. Use a pencil to mark the location for the remaining servo mounting block.

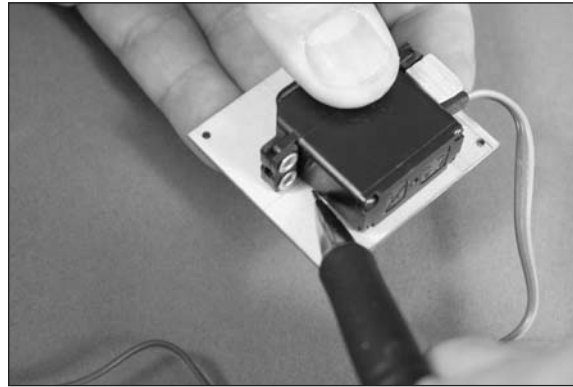

- ○ 8. Use 5-minute epoxy to glue the remaining block to the cover. Don't forget to roughen the end of the block as shown in step 6.

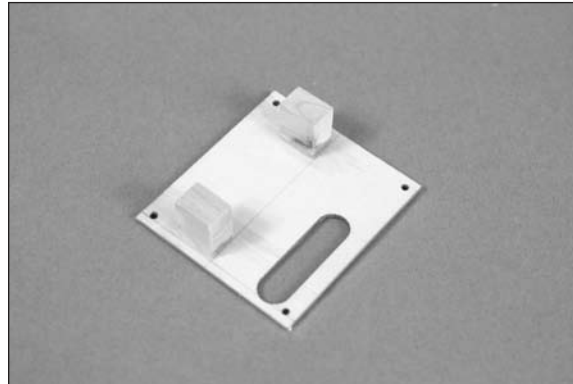

- ○ 9. Position the servo between the two blocks. Leave a small gap between the servo and servo cover so vibrations from the airframe are not transferred directly into the servo. Use a pencil to mark the locations for the four servo mounting screws on the blocks.

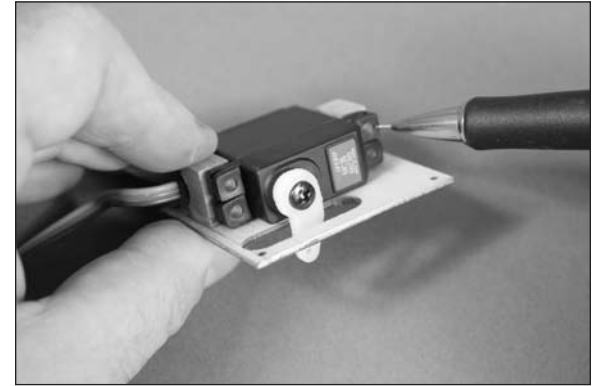

- ○ 10. Use a drill and 5/64-inch (2mm) drill bit to drill the holes for the mounting screws. Use care not to enlarge the holes any larger than the drill bit.



- 11. Apply 2–3 drops of thin CA in each hole drilled. Also saturate the front and rear of the block using thin CA to harden the block. This will help keep the block from splitting when the servo mounting screws are installed.

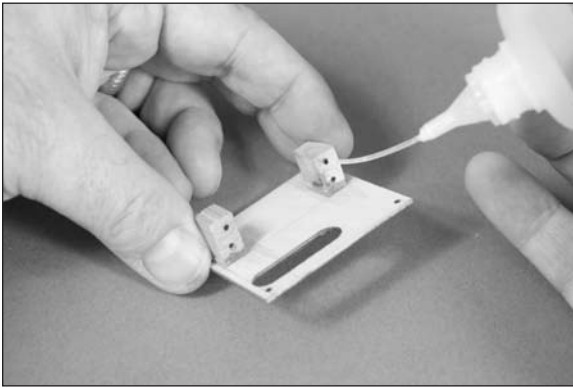
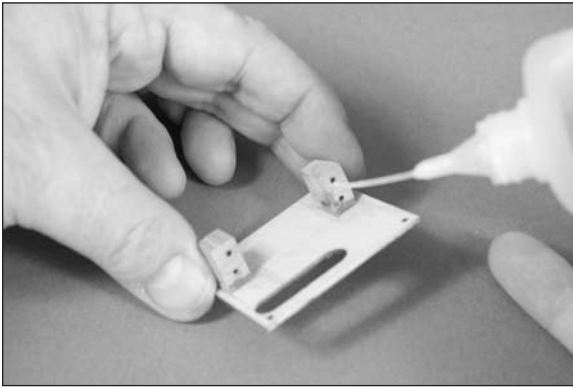

E-tips

Do not use a CA accelerator. Using an accelerator will not allow the CA to soak into the fibers of the wood, hardening the blocks.

- 12. Use the screws provided with the servo and a #1 Phillips screwdriver to attach the servo to the mounting blocks.

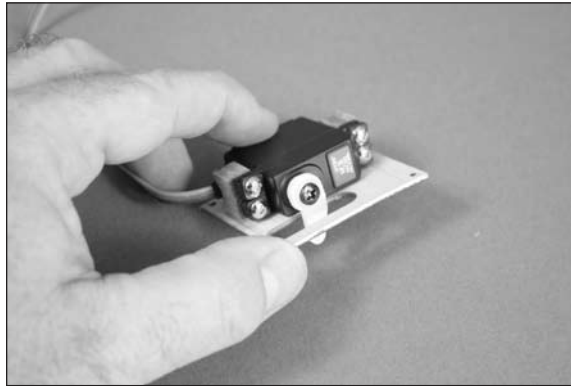

- 13. Apply 2–3 drops of thin CA in each of the flap servo cover mounting holes. This will harden the surrounding wood, making the screws more secure when they are installed.

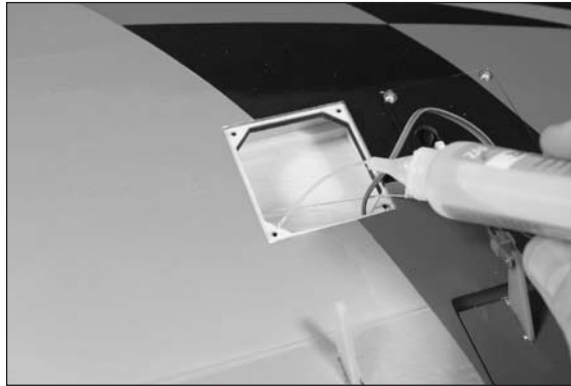

E-tips

Place a piece of low-tack tape on the flap servo lead so it can be identified easily from the aileron servo lead.

- 14. Tie the end of the string around the end of the flap and aileron servo leads. Use the string to pull the leads through the wing and out at the root rib as shown.

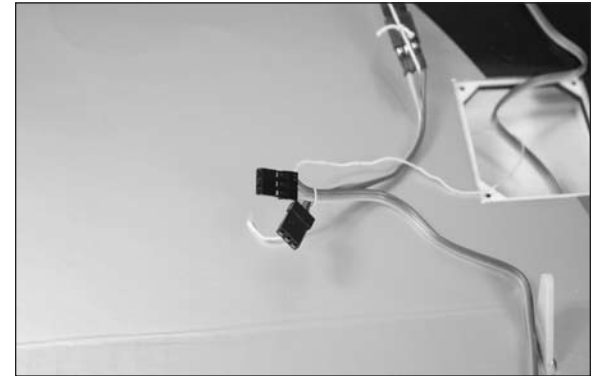

E-tips

Use low-tack tape to tape the flap and aileron servo connectors together. This will make them easier to pull through the wing.

- 15. Use four 2mm x 8mm self-tapping screws and a #1 Phillips screwdriver to secure the flap servo cover to the wing.

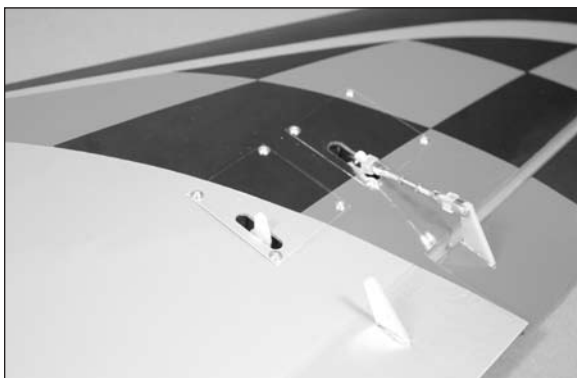

- 16. Use a hobby knife with a #11 blade to trim two 1/4-inch (6mm) pieces from the silicone tubing.

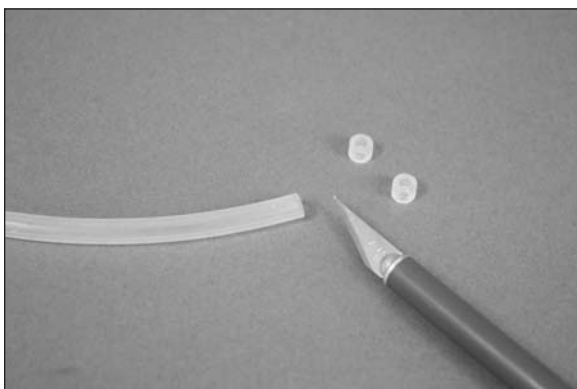

E-tips

Always use threadlock on metal-to-metal fasteners to prevent them from vibrating loose.

- 17. Assemble the flap linkage using the two pieces of tubing from the previous step, two 2mm nuts, two metal clevises and the 2mm x 25mm threaded rod. The length of the rod will be adjusted in the following steps.

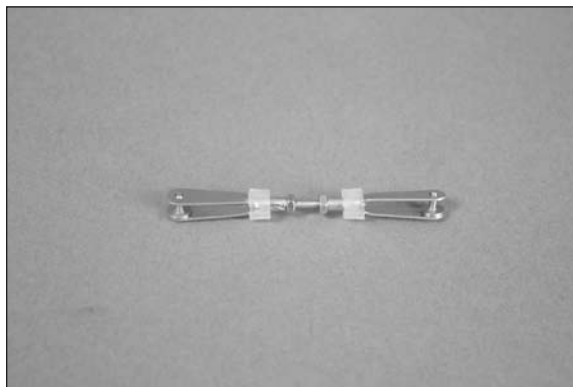

- 18. Use the radio system to center the flap servo. Connect the metal clevis to the outer hole of flap servo horn. The remaining clevis connects to the flap control horn. Adjust the length of the linkage so the flap is set to the mid/takeoff position of 11mm. Once the length of the linkage has been adjusted, slide the tubing over the forks of the clevises to keep them from accidentally opening in flight. Use needle nose pliers to tighten the nuts against the metal clevises.

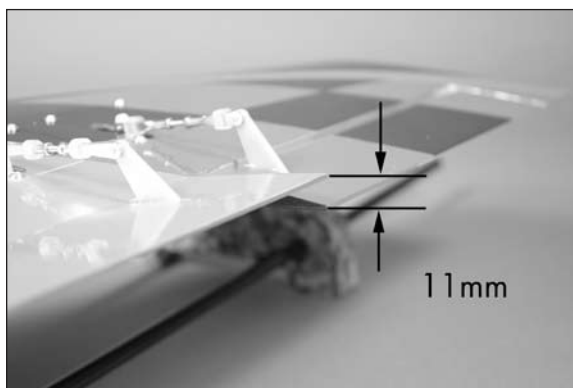

- 19. Set the switch at the transmitter to the UP flap position. Adjust the flap system values of the transmitter for the up position until the flap is aligned with the aileron. This will be the UP flap position.



- 20. Set the switch at the transmitter to the DOWN flap position. Adjust the ATV at the transmitter for the down position until the flap is 25mm below the aileron. This will be the DOWN flap position.

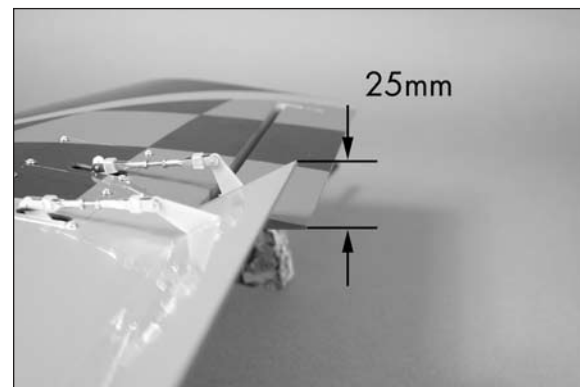

E-tips

Because there can be minor differences in control horn and servo positions, do not connect the linkage as described in steps 19 and 20 to the opposite flap until you have checked the throws. Doing so may cause the servo to bind in the UP position, which could cause damage to the flap servo.

- 21. Repeat steps 3 through 18 to install the remaining flap servo and assemble the flap linkage. Connect the flap linkage to the flap control horn ONLY at this time.

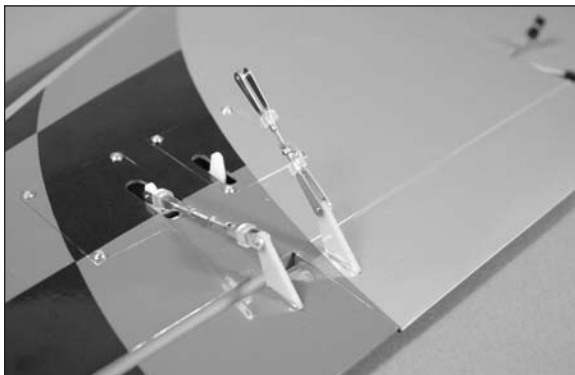

- 22. Set the flap switch to the UP flap position. Connect the linkage to the flap servo and adjust its length until the flap is aligned with the aileron. This will be the UP flap position.

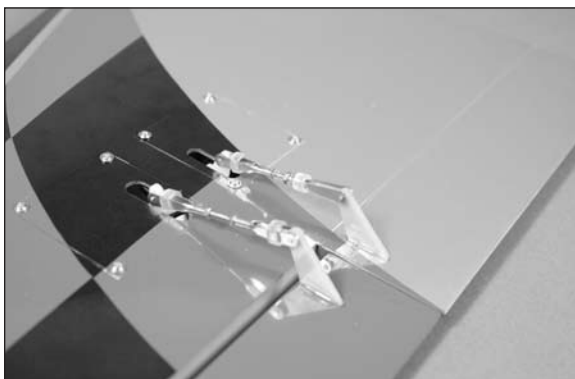

E-tips

You may have to fine-tune both flap linkages up or down so they align at all three positions: up, middle, and down. It is very important to use servo arms positioned at the same angle on the splines of the servo so the travel will match in all positions.

Wing Spar Installation

Required Parts

Fuselage Carbon wing spar (2)
8-32 x 1/4-inch socket head screw (4)
Wing panel assembly (right and left)

Required Tools and Adhesives

Low-tack tape Phillips screwdriver: #1
15-minute epoxy Mixing cup
Paper towels Mixing stick
Epoxy brush Rubbing alcohol
Ruler Medium grit sandpaper
Petroleum jelly Felt-tipped pen
Ball driver: 9/64-inch

- 1. Use a #1 Phillips screwdriver to remove the four 2mm x 8mm screws that hold the fan cover to the fuselage. Set the screws and cover aside in a safe location.

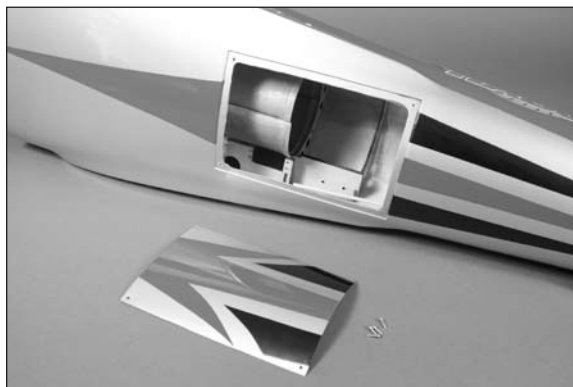

- 2. Slide the canopy hatch pin rearward and lift the canopy from the fuselage. The canopy is held in place with two pins at the front. Set the canopy aside so it doesn't get damaged.



- 3. Use a 9/64-inch ball driver to start the four 8-32 x 1/4-inch socket head bolts in the aluminum wing sockets inside the fuselage. Only thread the screws in a few turns at this time. Use care not to cross-thread the screws and damage the threads in the aluminum sockets.



- ○ 4. Locate the carbon wing spar. Use a straight edge or rest the joiner on a flat surface. The top of the joiner is flat, while the bottom will have a slight angle as shown in the drawing. This is necessary to conform to the dihedral built into the model.

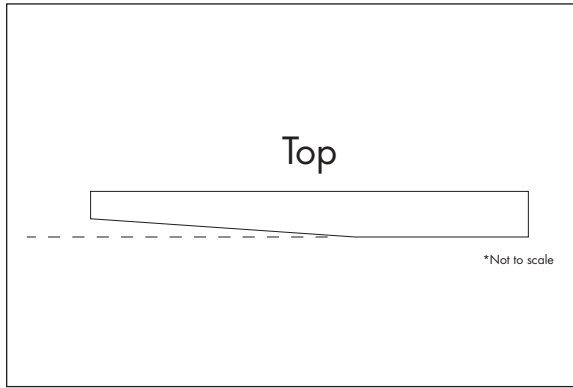

- ○ 5. Slide the carbon wing spar in the spar pocket of the wing, narrow end first. Make sure the top of the spar is to the top of the wing. The spar will slide in easily, so don't force it in any further than it will slide. Use a felt-tipped pen to mark the spar at the wing root.

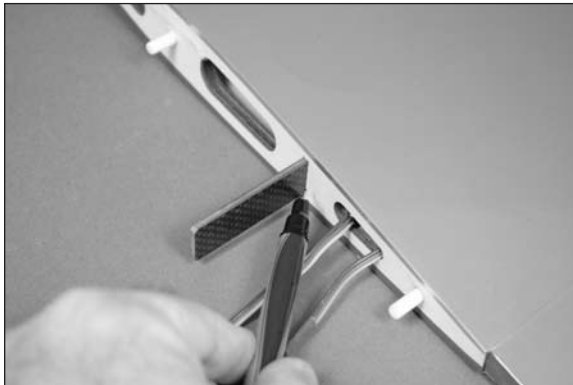

- ○ 6. Remove the spar from the spar pocket. Use medium grit sandpaper to lightly sand the spar where it fits into the wing. Sand both the front and back of the spar.

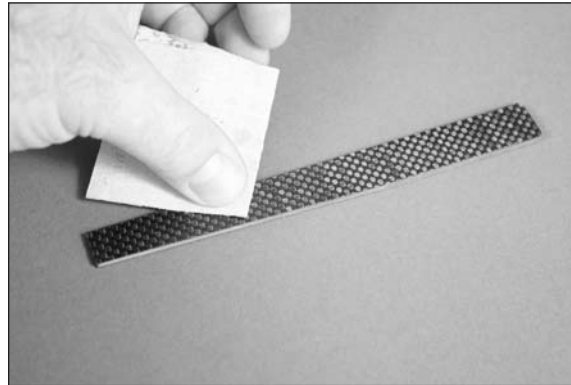

- ○ 7. Slide the spar into the spar pocket in the fuselage. It will easily slide into the pocket up to the line made in step 5. If not, the screws installed in step 3 may be in the way and will need to be loosened.

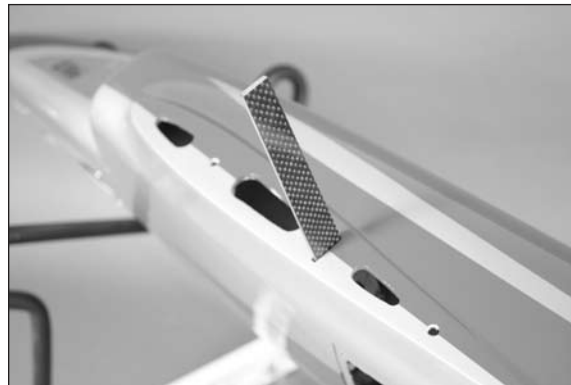

- ○ 8. Move the string used to pull the retract servo lead through the wing into the wing so it doesn't interfere with the fit of the wing to the fuselage.



- ○ 9. Check the fit of the wing on the fuselage. It must rest tightly against the fuselage. If the spar fits into the wing and fuselage spar pockets without any problems, the fit should be perfect. Make sure to guide the leads for the aileron and flap into the fuselage so they don't interfere with the fit.



- 10. Remove the wing and spar from the fuselage. Apply a thin coat of petroleum jelly to the fuselage around the wing socket. This will keep you from accidentally gluing the wing to the fuselage during the following procedure.

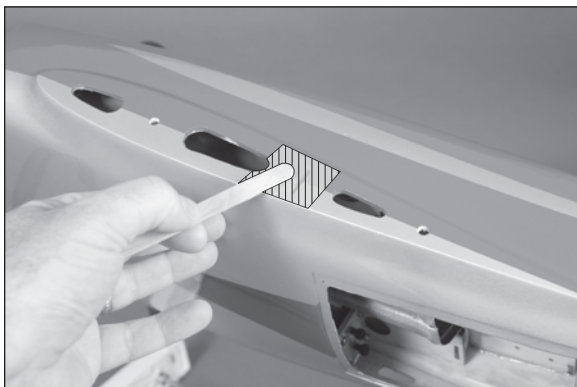

E-tips

Before mixing any epoxy, make sure to read through and understand the following steps. It is important to perform these steps before the epoxy fully cures.

- 11. Mix 1/2 ounce (15mL) of 15-minute epoxy. Apply the epoxy to the spar pocket of the wing using a mixing stick.



- 12. Use an epoxy brush to apply epoxy to the front, back, top and bottom of the spar where it fits into the wing.



- 13. Slide the spar into the spar pocket of the wing, making sure it is oriented correctly. Use a paper towel and rubbing alcohol to remove any excess epoxy from the wing and spar.



E-tips

Epoxy will ooze out from the spar pocket of the wing. If epoxy does not ooze out, not enough epoxy was used to glue the spar into the wing.

- 14. Before the epoxy cures, slide the wing into position against the fuselage. Keep the wing tight against the fuselage until the epoxy fully cures. You can use a 9/64-inch ball driver to lightly tighten the screws to secure the wing joiner in the fuselage, and low-tack tape to hold the wing in position until the epoxy has cured.



- 15. Once the epoxy has cured, remove the wing panel from the fuselage. Repeat steps 4 through 14 to install the remaining wing panel to the fuselage.
- 16. Once the epoxy has fully cured and both wing panels have spars, remove any petroleum jelly residue from the fuselage and wing using rubbing alcohol and a paper towel.

Main Landing Gear Installation - Fixed Gear

Required Parts

Wing panel assembly (right and left)
Aluminum wheel collar with setscrew, 3.5mm (2)
Aluminum wheel spacer, 3.5mm (2)
Wheel, 1³/₄-inch (44.5mm) (2)
Wheel axle adapter set (2)
Main landing gear strut (right and left)
Main fixed landing gear unit (2)
3mm x 14mm countersunk self-tapping screw (8)

Required Tools and Adhesives

Drill	Drill bit: 5/64-inch (2mm)
Threadlock	Hex wrench: 1.5mm
Thin CA	Phillips screwdriver: #1
Trim seal tool	Hobby knife with #11 blade
Triangle	Flat file

Note: If you are installing retracts, skip to the next section of this manual, Main Landing Gear Installation - Retractable Gear.

- 1. Use a hobby knife with a new #11 blade to remove the covering to access the landing gear mounts. Leave 1/32-inch (1mm) of covering around the inside edges. Use a trim seal tool to iron down the covering around the edges to finish the opening.



- 2. Place a main landing gear block in the wing. It may distort the covering slightly during its installation. Make sure it is resting flat on the landing gear rails.

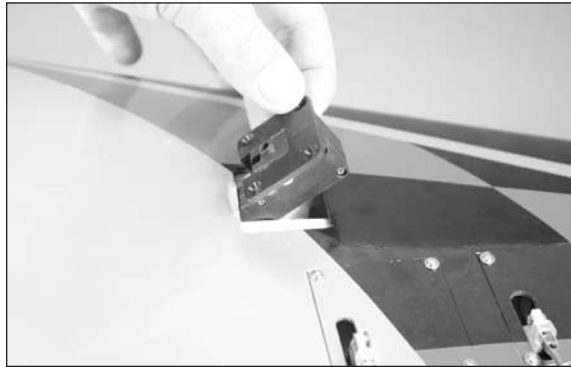

- 3. Prepare a 5/64-inch (2mm) drill bit by wrapping a piece of low-tack tape around the drill bit 5/8-inch (16mm) from the end of the bit. This will act as a marker so you don't accidentally drill through the top of the wing. Place the drill bit in a drill.



- 4. Use the drill and drill bit prepared in the previous step to drill the four holes for the landing gear block mounting screws.

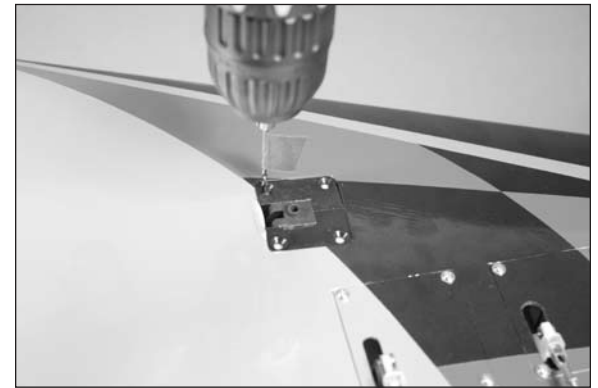

- 5. Remove the landing gear block from the wing. Use a #1 Phillips screwdriver to thread a 3mm x 14mm countersunk self-tapping screw in each hole to cut threads into the landing gear rails. Remove the screws after threading the holes.

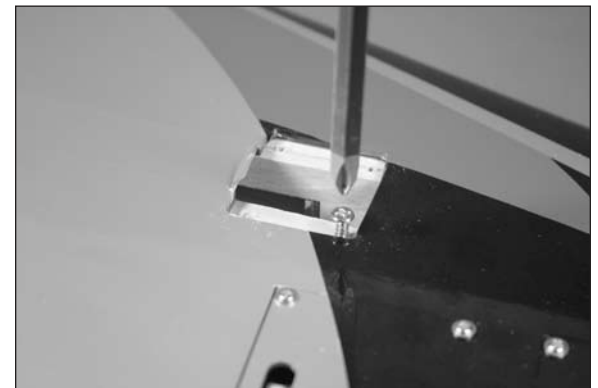

- 6. Place 2–3 drops of thin CA in each of the holes. This will harden the threads made by the screws making them more secure when the landing gear block is installed.

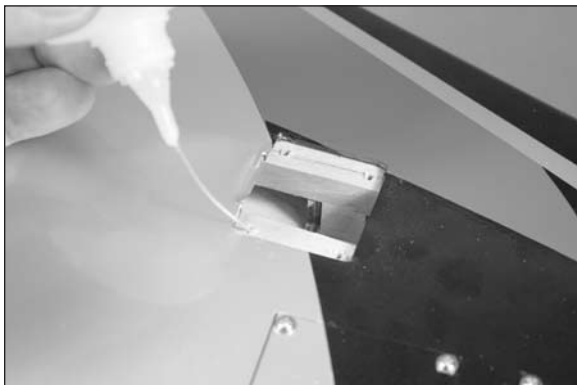

E-tips

Always use threadlock on metal-to-metal fasteners to prevent them from vibrating loose.

- 7. Slide a main gear strut into the main landing gear block. Use the setscrews and a 1.5mm hex wrench to secure the main gear wire in the block. The setscrews will tighten down on each side of the flat at the top of the strut to prevent the strut from rotating in the block. Assemble the right and left main gear assemblies at this time.

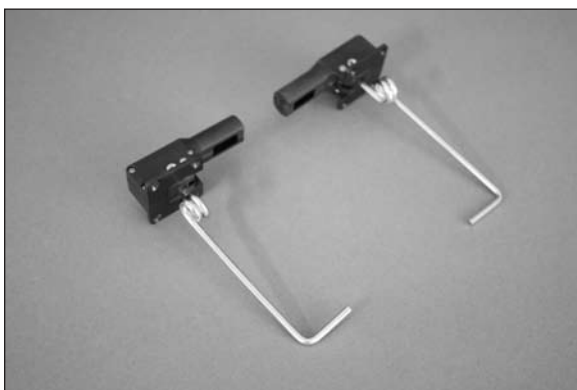

- 8. Place the correct main gear assembly in position. The axle will face to the root of the wing, and the spring will face to the trailing edge of the wing. Use four 3mm x 14mm countersunk self-tapping screws and a #1 Phillips screwdriver to tighten the screws.

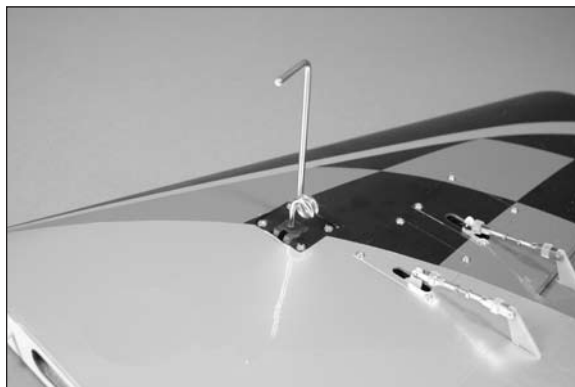

- 9. With the flap lowered, rest a square against the flap hinge line. Look down on the axle and check that it is perpendicular to the square as shown. If not, it may be necessary to lightly file the flat areas on the landing gear wire to correct for any misalignment.



- 10. Select the correct adapter that fits to the landing gear strut. Insert two adapters in either side of the hub of the wheel.



- 11. Use a flat file to make a 1/4-inch (6mm) wide flat area on the gear near the end of the axle strut for the setscrew to rest. This will keep the wheel collar from vibrating loose in flight.

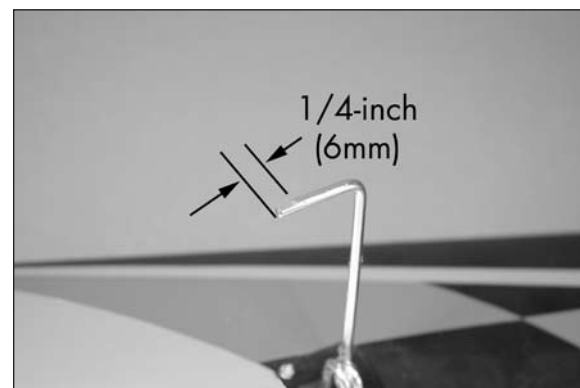

Etips

The end of the axles may have a slight bur on them from the factory. If the wheel is hard to install use a file to remove this bur.

Etips

Always use threadlock on metal-to-metal fasteners to prevent them from vibrating loose.

- 12. Slide a 3.5mm aluminum wheel spacer on the axle, then the wheel with adapters. A 3.5mm wheel collar is used to secure the wheel in position by tightening the setscrews onto the axle using a 1.5mm hex wrench.

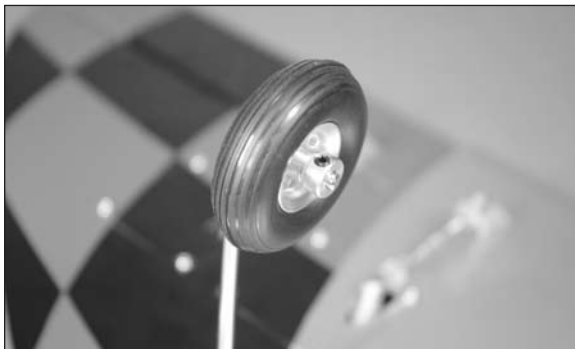

- 13. Repeat steps 1 through 12 to install the remaining main landing gear and wheel.

Main Landing Gear Installation - Retractable Gear

Required Parts

Transmitter	Receiver
Receiver battery	
Wing panel assembly (right and left)	
Servo extension, 3-inch (76mm) (2)	
Aluminum wheel collar with setscrew, 3.5mm (2)	
Aluminum wheel spacer, 3.5mm (2)	
Wheel, 1 ³ / ₄ -inch (44.5mm) (2)	
Wheel axle adapter set (2)	
Main landing gear strut (right and left)	
Main landing gear retract (2)	
3mm x 14mm countersunk self-tapping screw (8)	

Required Tools and Adhesives

Drill	Drill bit: 5/64-inch (2mm)
Threadlock	Hex wrench: 1.5mm
Thin CA	Phillips screwdriver: #1
String	Scissors
Trim seal tool	Hobby knife with #11 blade

- 1. Use a hobby knife with a new #11 blade to remove the covering for the retract mechanism and landing gear assembly. Leave 1/32-inch (1mm) of covering around the inside edges. Use a trim seal tool to iron down the covering around the edges to finish the opening.

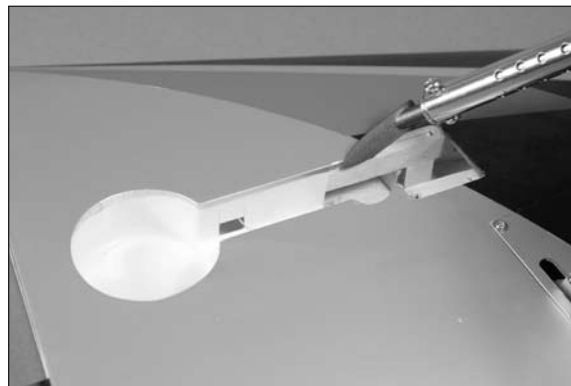

- 2. Use a 1.5mm hex wrench to remove the strut from the retract mechanism.

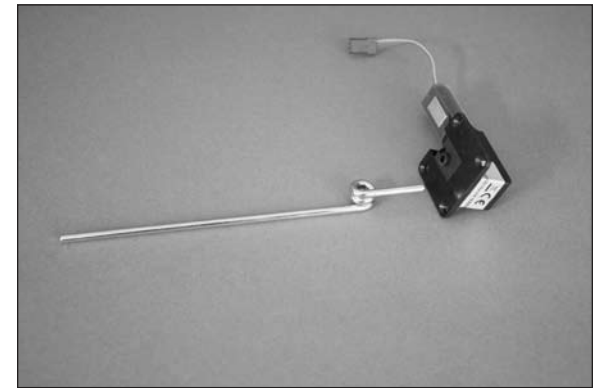

- 3. Place the retract mechanism in the wing. Make sure it is resting flat on the landing gear rails.

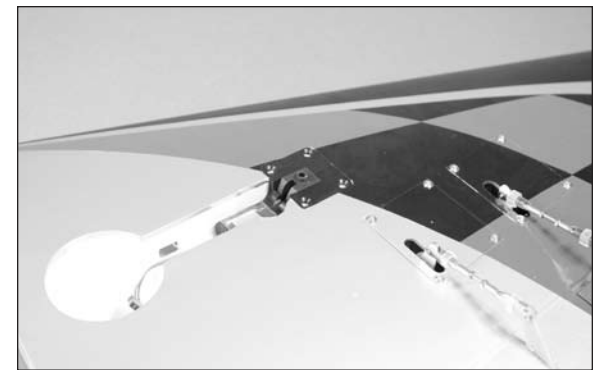
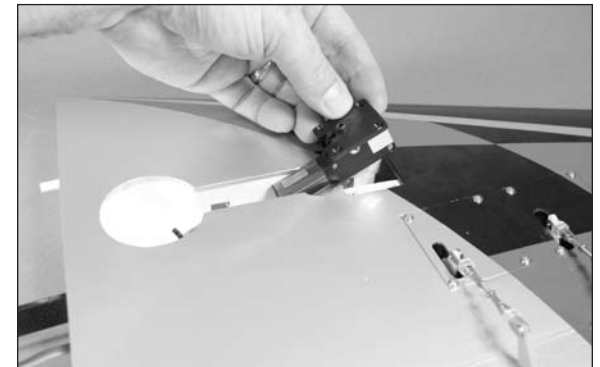

- ○ 4. Prepare a 5/64-inch (2mm) drill bit by wrapping a piece of low-tack tape around the drill bit 5/8-inch (16mm) from the end of the bit. This will act as a marker so you don't accidentally drill through the top of the wing. Place the drill bit in a drill.



- ○ 5. Use the drill and drill bit prepared in the previous step to drill the four holes for the landing gear block mounting screws.

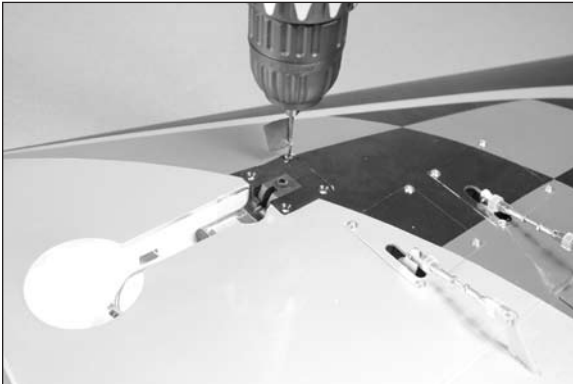

- ○ 6. Remove the retract mechanism from the wing. Use a #1 Phillips screwdriver to thread a 3mm x 1.4mm countersunk self-tapping screw in each hole to cut threads into the landing gear rails. Remove the screws after threading the holes.

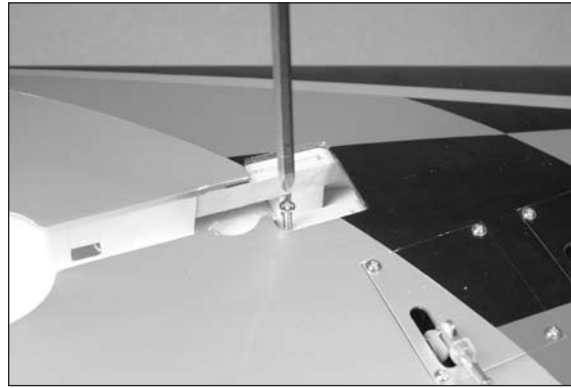

- ○ 7. Place 2-3 drops of thin CA in each of the holes. This will harden the threads made by the screws making them more secure when the landing gear block is installed.

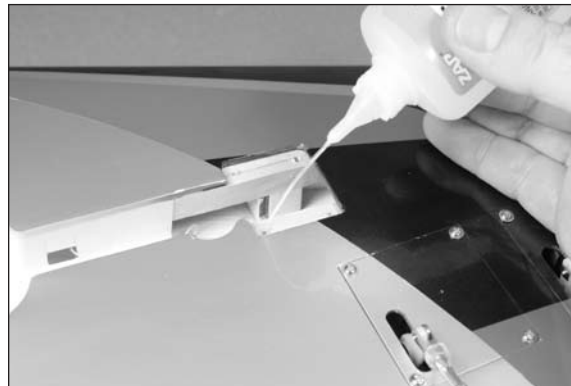

E-tips

We have designed the main gear struts to work with both the fixed gear and the suggested retracts. These struts are designed for the weight and speeds of the Habu. Use the struts supplied with the kit for the retract assemblies.

E-tips

Always use threadlock on metal-to-metal fasteners to prevent them from vibrating loose.

- ○ 8. Slide a main gear strut into the retract mechanism. Use the setscrews and a 1.5mm hex wrench to secure the main gear wire in the mechanism. The setscrews will tighten down on the flats at the top of the strut to prevent the strut from rotating in the block. Assemble the right and left main gear retract assemblies at this time.

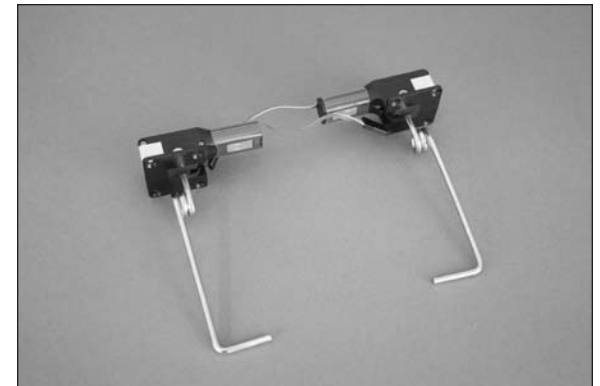

Note: The first shipment of EFL 15-25 size retracts were shipped with only one setscrew holding in the main strut. This is fine for the lower weight limits of the retracts, but for the higher end of the weight limits, we suggest using a setscrew in each side of the strut. Future shipments will have a setscrew in each side of the unit. If your units only have a setscrew in one side of the unit, remove another setscrew for each of the fixed gear units supplied with the kit.

- 9. Secure a 3-inch (76mm) servo extension to the lead on the retract mechanism using string or a commercially available connector.

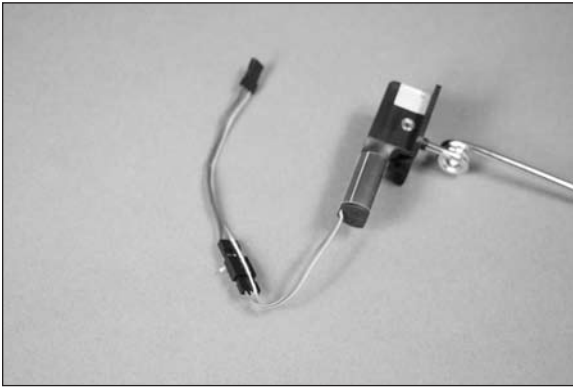

- 10. Tie the end of the string around the end of the extension. Use care not to pull the string from the wing.

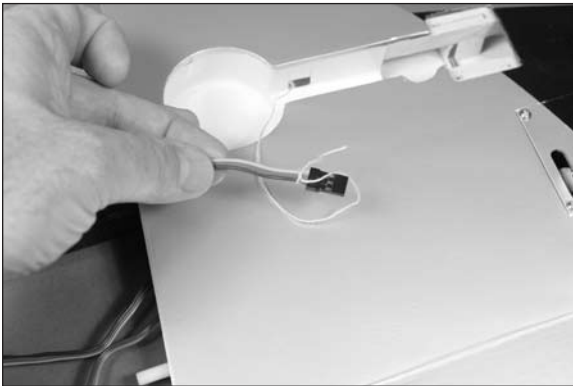

- 11. Use the string to pull the lead through the wing and out at the root rib as shown. Remove the string once the lead has been pulled through.



- 12. Place the correct retract assembly in position. The axle will face to the root of the wing, and the spring will face to the trailing edge of the wing. Use four 3mm x 14mm countersunk self-tapping screws and a #1 Phillips screwdriver to tighten the screws.

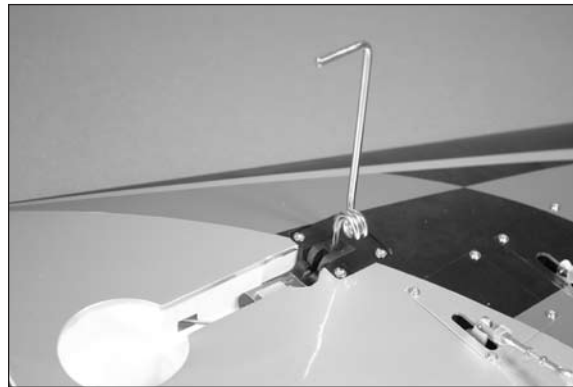

- 14. Select the correct adapter that fits to the landing gear strut. Insert two adapters in either side of the hub of the wheel.



- 15. With the flap lowered, rest a square against the flap hinge line. Look down on the axle and check that it is perpendicular to the square as shown. If not, it may be necessary to lightly file the flat areas on the landing gear wire to correct for any misalignment.



- 16. Use a flat file to make a 1/4-inch (6mm) wide flat area on the gear near the end of the axle strut for the setscrew to rest. This will keep the wheel collar from vibrating loose in flight.

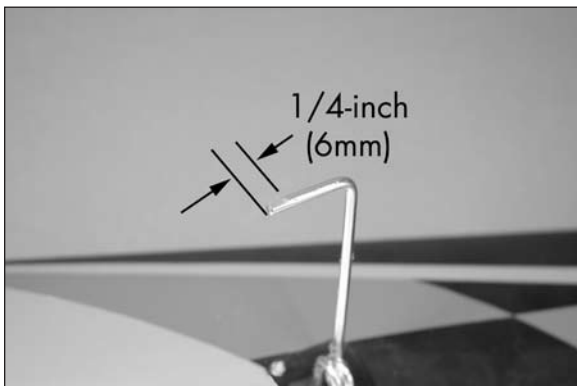

E-tips

Always use threadlock on metal-to-metal fasteners to prevent them from vibrating loose.

- 17. Slide a 3.5mm aluminum wheel spacer on the axle, then the wheel with adapters. A 3.5mm wheel collar is used to secure the wheel in position by tightening the setscrews onto the axle using a 1.5mm hex wrench.



E-tips

The end of the axles may have a slight bur on them from the factory. If the wheel is hard to install use a file to remove this bur.

- 18. Check to make sure the axle is flush with the edge of the outer wheel collar. If not, use a rotary tool and cutoff wheel to trim the axle flush with the wheel collar. Make sure to remove the wheel so the heat generated from the cutting does not melt the bushings in the wheel.



- 19. Check the operation of the retract using the radio system. The wheel will retract into the center of the wheel well. If not, slightly bend the strut so it does.



- 20. Repeat steps 1 through 19 to install the remaining main landing gear and wheel.

Optional Main Landing Gear Doors

Required Parts

Wing assembly (right and left)

Transmitter Receiver

Receiver battery Landing gear door (2)

2mm x 8mm self-tapping screw (8)

Landing gear door block (4)

Required Tools and Adhesives

Rotary tool Sanding drum

Sanding block Medium grit sandpaper

Ruler Pencil

Pin vise Drill

Canopy glue Drill bit: 1/16-inch (1.5mm)

Thin CA Side cutter

Phillips screwdriver: #0

Note: The installation of the landing gear doors is optional and they can be installed at any time during the life of your model.

- 1. Use a pencil to draw a centerline on the unpainted side of the landing gear door.

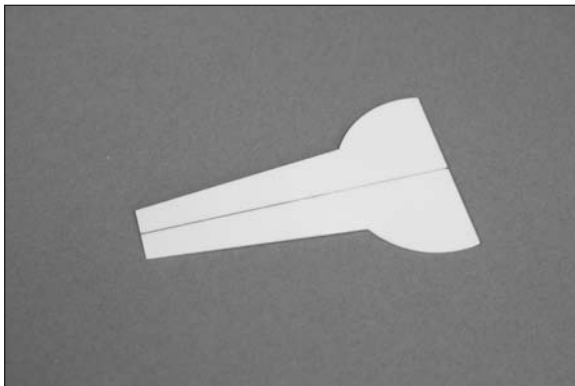

- 2. Draw two lines on the door that are 7/8-inch (22mm) and 2⁵/₈-inch (65mm) from the top edge of the landing gear door as the center lines for the mounting blocks.

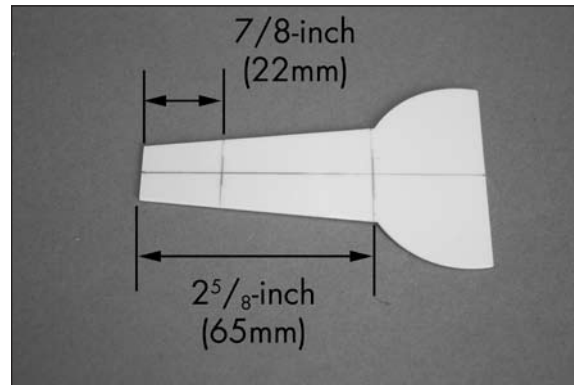

- 3. Use a pin vise and 1/16-inch (1.5mm) drill bit to drill four holes in the landing gear door that are 3/16-inch (5mm) from the centerline along the lines drawn in the previous step.

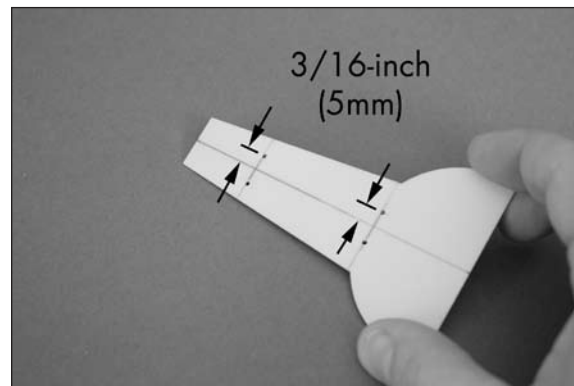

- 4. Use a straight edge or ruler to lightly bend the landing gear door so it will rest tightly against the wing when the gear are retracted. Work slowly to avoid cracking the paint on the outside of the landing gear door.

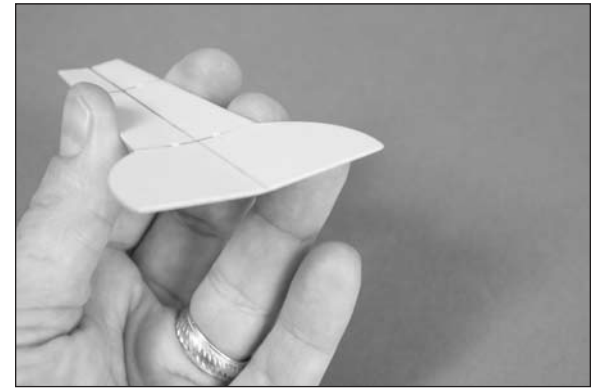

- 5. Locate the landing gear door blocks. Use a sanding block and medium grit sandpaper to sand an angle on the notched side so the block will rest flat against the angle of the landing gear door. Prepare both blocks at this time.

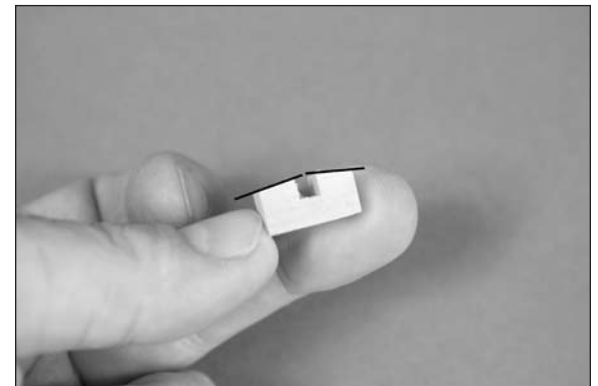

- ○ 6. Rest the landing gear door block on the gear door, centering it on the lines previously drawn. Use a pencil to transfer the mounting holes from the landing gear door onto the block.

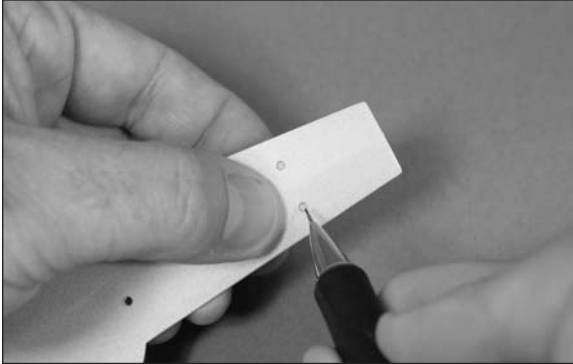
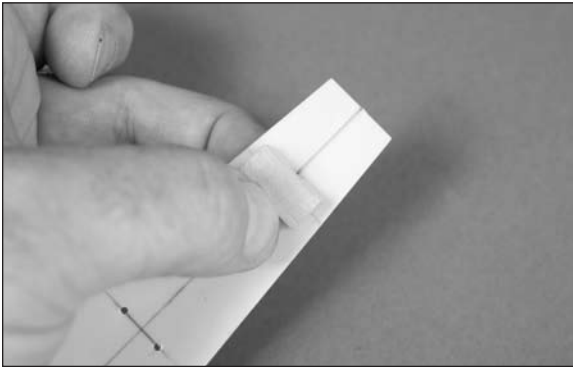

- ○ ○ ○ ○ ○ ○ ○ 7. Use a drill and 1/16-inch (1.5mm) drill bit to drill the two mounting holes in the landing gear door block.

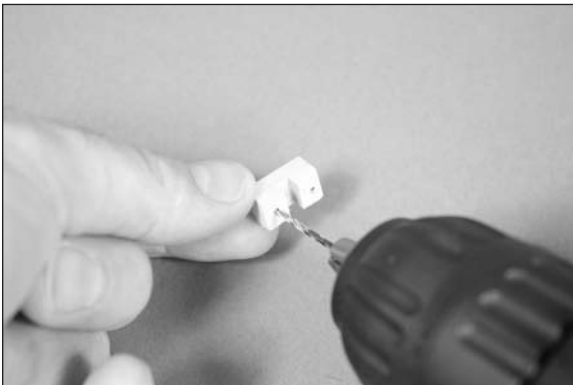

- ○ ○ ○ 8. Use a sanding block and medium grit sandpaper to round the back of the landing gear door block. This will allow the gear to retract into the wing and help center the gear while it is retracting.



- ○ ○ ○ ○ ○ ○ ○ 9. Use a #0 Phillips screwdriver to install a 2mm x 8mm self-tapping screw in each of the mounting holes in the landing gear door block. Remove the screws after cutting the threads in the blocks.

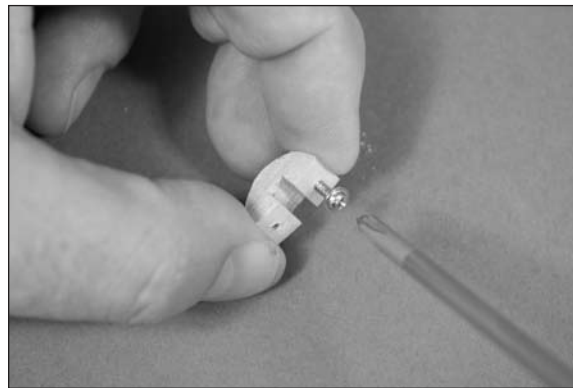

- ○ ○ ○ ○ ○ ○ ○ 10. Place 2–3 drops of thin CA in each of the mounting holes. This will harden the threads made by the screws making them more secure when the landing gear door is installed.

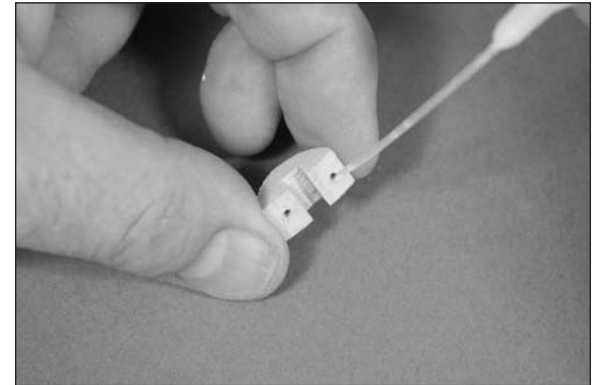

- ○ 11. Repeat steps 7 through 10 to prepare the second landing gear door mounting block.
- ○ 12. Attach the landing gear door to the strut using four 2mm x 8mm self-tapping screws and a #0 Phillips screwdriver.



Etips

Work slowly when using a sanding drum on the screws. The screws will heat up while sanding, which could melt the landing gear door.

- 13. Use side cutters and a rotary tool with a sanding drum to smooth the ends of the screws against the inside of the blocks. If this is not done, the screws could catch on the edges of the retract opening and cause the gear to not retract correctly.



- 14. Slide the landing gear door so the top block is resting against the coil of the landing gear strut. Apply a thin bead of canopy glue along the front and back of the strut against the landing gear door. Rotate the door a few times to work the glue behind the strut.

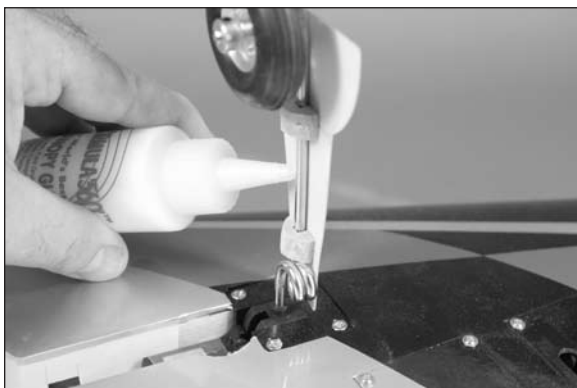

- 15. Retract the landing gear using the radio system. This will set the correct angle for the landing gear door against the wing. Allow the glue to cure overnight before moving the gear back to the down position.



- 16. Repeat steps 1 through 15 to install the second landing gear door.

Nose Gear Installation - Fixed Gear

Required Parts

Fuselage assembly	Fixed nose gear assembly
Transmitter	Receiver
Receiver battery	Silicone tubing
Metal clevis (2)	2mm nut (2)
Threaded rod, 2 ¹ / ₄ -inch (57mm)	
Servo with hardware (MC35)	
3mm x 8mm socket head screw (4)	
Aluminum wheel collar with setscrew, 3.5mm	
Aluminum wheel spacer, 3.5mm	
Wheel, 1 ³ / ₄ -inch (44.5mm)	
Wheel axle adapter set	

Required Tools and Adhesives

Pliers	Phillips screwdriver: #1
Side cutter	Hobby knife with #11 blade
Clear tape	Threadlock
Hex wrench: 1.5mm, 2.5mm	

- 1. Use a #1 Phillips screwdriver to remove the four 2mm x 8mm self-tapping screws that secure the nose gear cover to the fuselage. Set the cover and screws aside until later in the section of the manual.



- 2. Use a #1 Phillips screwdriver to thread a servo mounting screw into the mounting holes for the steering servo. Remove the screw after cutting the threads in the plywood. The opening for the steering servo is the center opening in the forward servo tray.



Note: The 2 extra servo holes on each side of the nose gear servo hole are not used and are just there if needed.

- 3. Place 2–3 drops of thin CA in each of the holes. This will harden the threads made by the screws making them more secure when the steering servo is installed.



- 4. Prepare the steering servo by installing the rubber grommets and brass eyelets as shown in the radio or servo instructions. Center the steering servo using the radio system. Use side cutters to remove any arms from the horn that may interfere with the operation of the servo. Do not secure the horn to the servo, as it will need to be removed when adjusting the steering linkage.

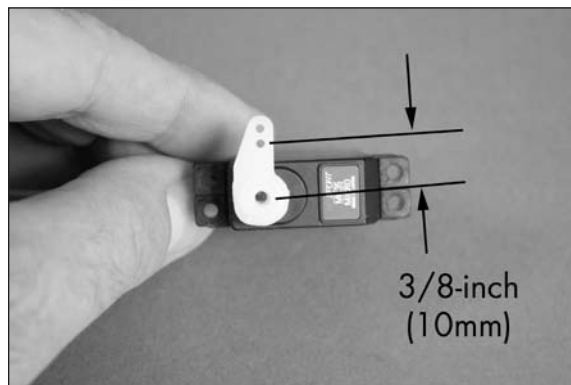

E-tips

The steering linkage will be connected to the hole in the servo that is 3/8-inch (10mm) from the center of the arm as illustrated in the photo above.

- 5. Install the steering servo in the fuselage using the hardware provided with the servo and a #1 Phillips screwdriver. The servo output faces the rear of the fuselage.



- 6. Use a hobby knife with a #11 blade to trim a 1/4-inch (6mm) piece from the silicone tubing.



E-tips

Always use threadlock on metal-to-metal fasteners to prevent them from vibrating loose.

- 7. Slide the piece of silicone tubing on one of the metal clevises. Assemble the steering linkage by threading a 2mm nut and metal clevis on either end of the 2 1/4-inch (57mm) threaded rod as shown. Thread the clevis without the tubing so the threads are barely visible between the forks of the clevis, then use pliers to tighten the nut against the clevis to keep the clevis from moving.



- 8. Connect the clevis without the tubing to the steering arm of the nose gear assembly.

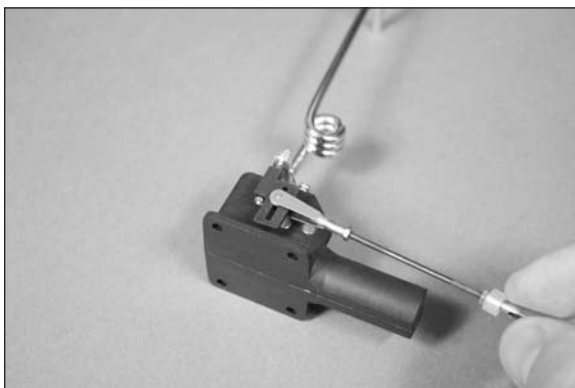

E-tips

Cut a 1/2-inch (13mm) piece of silicone tubing and slide it on a 2.5mm hex wrench. The 3mm screw can then be placed in the tubing and against the hex wrench so it can be easily installed to secure the landing gear.



- 9. Secure the nose gear assembly in the fuselage using four 3mm x 8mm socket head screws.

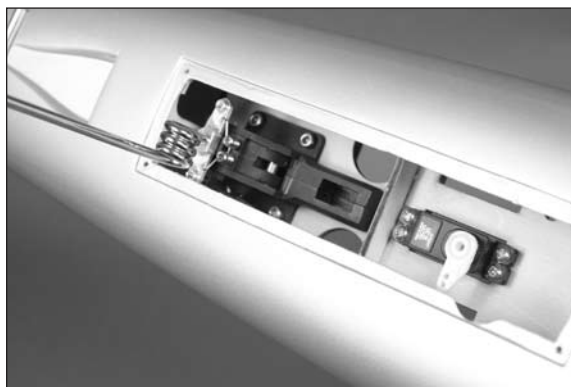

- 10. Remove the horn from the servo and attach the clevis to the horn. Place the horn on the servo and check that the steering is centered when the steering servo is centered. Once the linkage is set, tighten the 2mm nut against the clevis using pliers so the clevis doesn't vibrate loose. Slide the silicone over the forks of the clevis and install the screw to secure the servo horn to the servo using a #1 Phillips screwdriver.

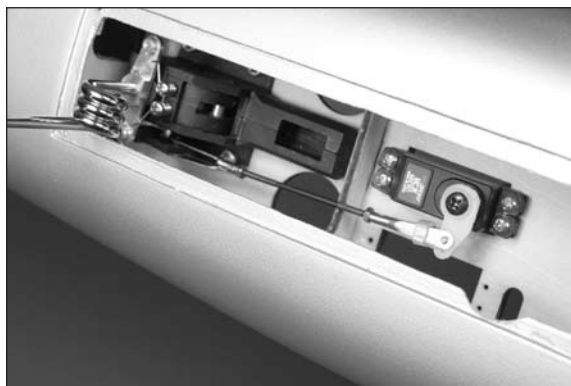

E-tips

Always use threadlock on metal-to-metal fasteners to prevent them from vibrating loose.

- 11. Attach the nose gear cover to the fuselage using a #1 Phillips screwdriver and the four 2mm x 8mm self-tapping screws removed in step 1.

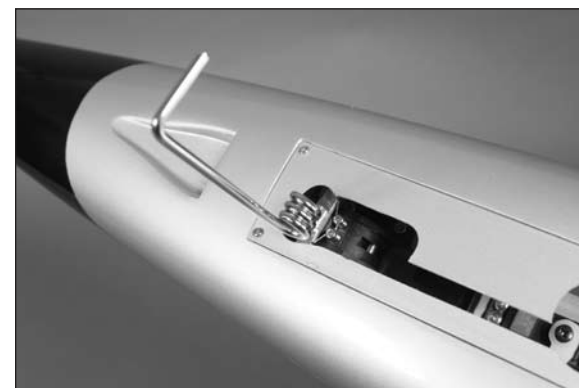

E-tips

Add clear tape to both sides of the nose gear door to help secure it to the fuselage.

- 12. Select the correct adapter that fits to the landing gear strut. Insert two adapters in either side of the hub of the wheel.

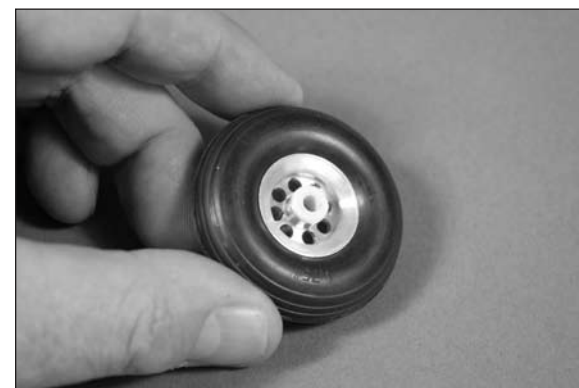

- 13. Use a flat file to make a 1/4-inch (6mm) wide flat area on the gear near the end of the axle strut for the setscrew to rest. This will keep the wheel collar from vibrating loose in flight.

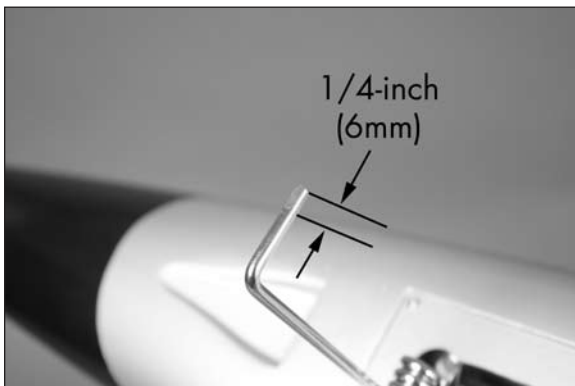

E-tips

Always use threadlock on metal-to-metal fasteners to prevent them from vibrating loose.

- 14. Slide a 3.5mm aluminum wheel spacer on the axle, then the wheel with adapters. A 3.5mm wheel collar is used to secure the wheel in position by tightening the setscrews onto the axle using a 1.5mm hex wrench.



E-tips

The end of the axles may have a slight bur on them from the factory. If the wheel is hard to install use a file to remove this bur.

Nose Gear Installation - Retracts

Required Parts

Fuselage assembly	Nose gear retract assembly
Transmitter	Receiver
Receiver battery	Silicone tubing
Metal clevis (2)	2mm nut (2)
Threaded rod, 2 ¹ / ₄ -inch (57mm)	
Servo with hardware (MC35)	
3mm x 8mm socket head screw (4)	
Aluminum wheel collar with setscrew, 3.5mm	
Aluminum wheel spacer, 3.5mm	
Wheel, 1 ³ / ₄ -inch (44.5mm)	
Wheel axle adapter set	

Required Tools and Adhesives

Pliers	Phillips screwdriver: #1
Side cutter	Hobby knife with #11 blade
Rotary tool	Sanding drum
Threadlock	Clear tape
Hex wrench: 1.5mm, 2.5mm	

- 1. Use a #1 Phillips screwdriver to remove the four 2mm x 8mm self-tapping screws that secure the nose gear cover to the fuselage. Set the cover and screws aside until later in the section of the manual.



- 2. Use a #1 Phillips screwdriver to thread a servo mounting screw into the mounting holes for the steering servo. Remove the screw after cutting the threads in the plywood. The opening for the steering servo is the center opening in the forward servo tray.



Note: The 2 extra servo holes on each side of the nose gear servo hole are not used and are just there if needed.

- 3. Place 2–3 drops of thin CA in each of the holes. This will harden the threads made by the screws making them more secure when the steering servo is installed.



- 4. Prepare the steering servo by installing the rubber grommets and brass eyelets as shown in the radio or servo instructions. Center the steering servo using the radio system. Use side cutters to remove any arms from the horn that may interfere with the operation of the servo. Do not secure the horn to the servo, as it will need to be removed when adjusting the steering linkage.

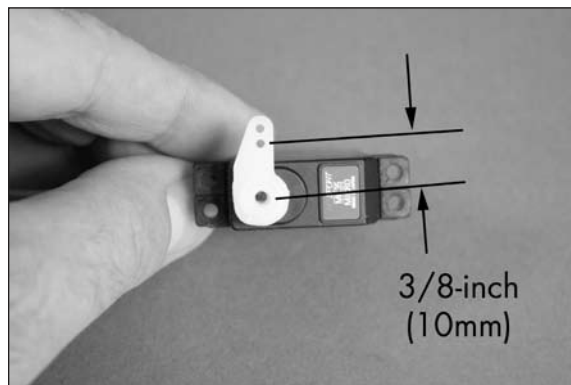

E-tips

The steering linkage will be connected to the hole in the servo that is 3/8-inch (10mm) from the center of the arm as illustrated in the photo above.

- 5. Install the steering servo in the fuselage using the hardware provided with the servo and a #1 Phillips screwdriver. The servo output faces the rear of the fuselage.



- 6. Use a hobby knife with a #11 blade to trim a 1/4-inch (6mm) piece from the silicone tubing.



E-tips

Always use threadlock on metal-to-metal fasteners to prevent them from vibrating loose.

- 7. Slide the piece of silicone tubing on one of the metal clevises. Assemble the steering linkage by threading a 2mm nut and metal clevis on either end of the 2 1/4-inch (57mm) threaded rod as shown. Thread the clevis without the tubing so the threads are barely visible between the forks of the clevis, then use pliers to tighten the nut against the clevis to keep the clevis from moving.

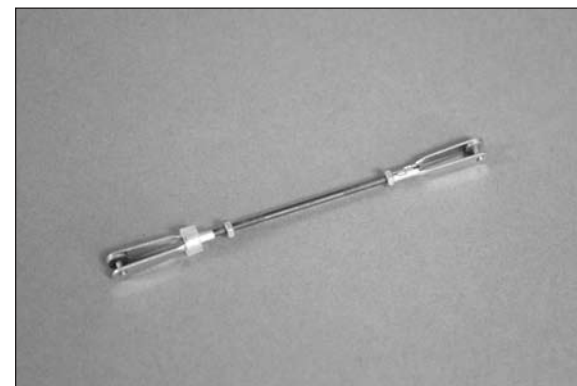

- 8. Use the radio system to move the nose gear retract to the UP position. Use a 1.5mm hex wrench to loosen the screw on the steering arm and wheel collar to remove the strut from the mechanism.

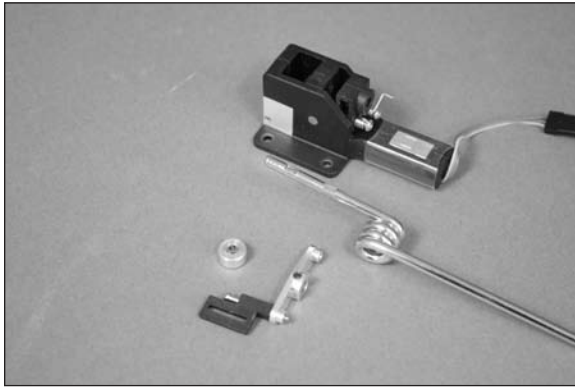

E-tips

We have designed the main gear struts to work with both the fixed gear and the suggested retracts. These struts are designed for the weight and speeds of the Habu. Use the struts supplied with the kit for the retract assembly.

E-tips

Always use threadlock on metal-to-metal fasteners to prevent them from vibrating loose.

- 9. Use a 1.5mm hex wrench to secure the steering arm by tightening the setscrew on the lower flat of the nose gear strut. Make sure the arm is positioned as shown in the photo.

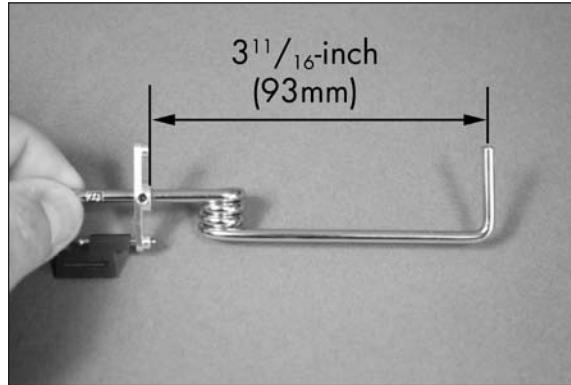

- 10. Install the supplied nose gear strut in the retract mechanism and tighten the setscrews using a 1.5mm hex wrench. The setscrews should align with the flat spots on the nose gear leg.

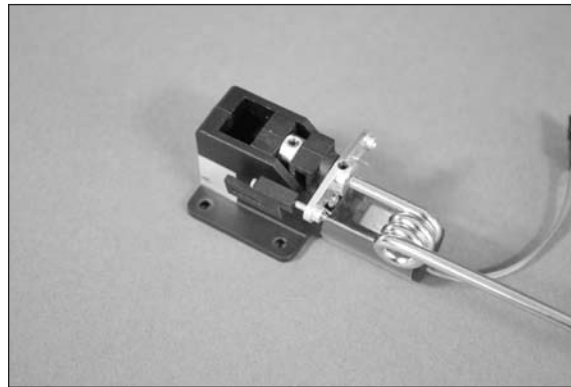

- 11. Connect the clevis without the tubing to the steering arm of the nose gear assembly.

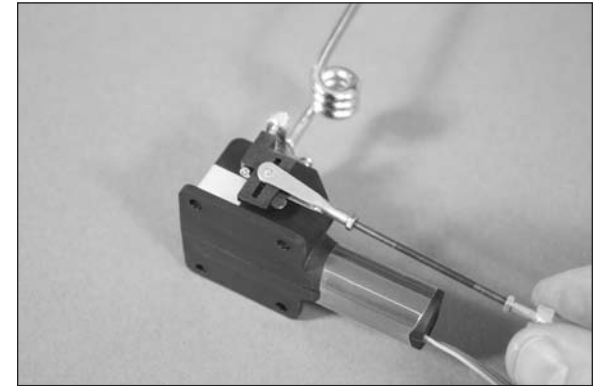

E-tips

Cut a 1/2-inch (13mm) piece of silicone tubing and slide it on a 2.5mm hex wrench. The 3mm screw can then be placed in the tubing and against the hex wrench so the screw can be easily installed to secure the landing gear.



E-tips

Always use threadlock on metal-to-metal fasteners to prevent them from vibrating loose.

- 12. Secure the nose gear assembly in the fuselage using four 3mm x 8mm socket head screws.

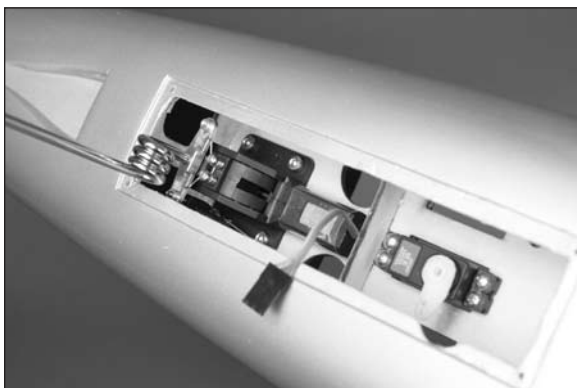

- 13. Remove the horn from the servo and attach the clevis to the horn. Place the horn on the servo and check that the steering is centered when the steering servo is centered. Once the linkage is set, tighten the 2mm nut against the clevis using pliers so the clevis doesn't vibrate loose. Slide the silicone over the forks of the clevis and install the screw to secure the servo horn to the servo using a #1 Phillips screwdriver.



- 14. Attach the nose gear cover to the fuselage using a #1 Phillips screwdriver and the four 2mm x 8mm self-tapping screws removed in step 1.

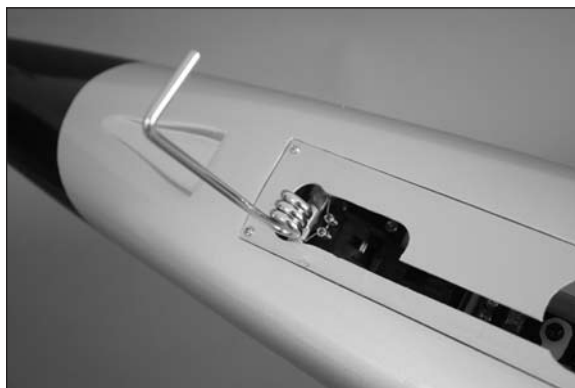

E-tips

Add clear tape to both sides of the nose gear door to help secure it to the fuselage.

Note: A solid nose gear plate has been supplied with your Habu 32 for those who want to have a fully functional nose gear door. The installation is not covered in the manual and is left up to the modeler for installation and operation. The installation of this plate will reduce the drag of the nose gear and provide a slight increase in speed of your model.

- 15. Select the correct adapter that fits to the landing gear strut. Insert two adapters in either side of the hub of the wheel.



E-tips

Always use threadlock on metal-to-metal fasteners to prevent them from vibrating loose.

- 16. Use a flat file to make a 1/4-inch (6mm) wide flat area on the gear near the end of the axle strut for the setscrew to rest. This will keep the wheel collar from vibrating loose in flight.

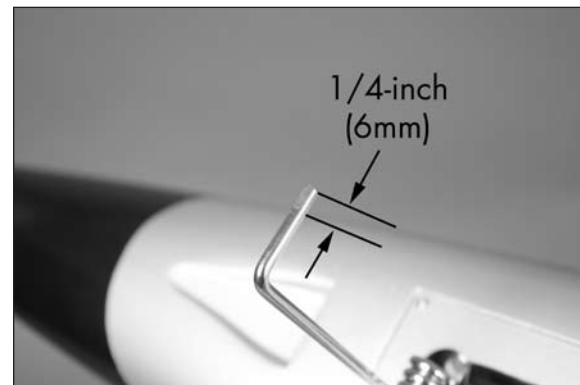

E-tips

The end of the axles may have a slight bur on them from the factory. If the wheel is hard to install, use a file to remove this bur.

- 17. Slide a 3.5mm aluminum wheel spacer on the axle, then the wheel with adapters. A 3.5mm wheel collar is used to secure the wheel in position by tightening the setscrews onto the axle using a 1.5mm hex wrench.



- 18. Check the operation of the nose gear retract using the radio system. The nose gear door is pre-cut to fit from the factory but some minor sanding and trimming may be needed for final fit. Use a hobby knife or rotary tool with a sanding drum for clearance.

Etips

The end of the axles may have a slight burr on them from the factory. If the wheel is hard to install, use a file to remove this burr.

Rudder Servo Installation

Required Parts

Fuselage assembly Threaded rod, 2 1/4-inch (57mm)
 Metal clevis (2) 2mm nut (2)
 Silicone tubing Servo with hardware (JR368)
 18-inch (457mm) servo extension

Required Tools and Adhesives

String Pliers
 Threadlock Phillips screwdriver: #1
 Side cutters Scissors
 Clear tape Thin CA

- 1. Secure an 18-inch (457mm) servo extension to the rudder servo using string or a commercially available connector.



- 2. Center the rudder servo using the radio system. Use side cutters to remove any arms from the horn that may interfere with the operation of the servo.

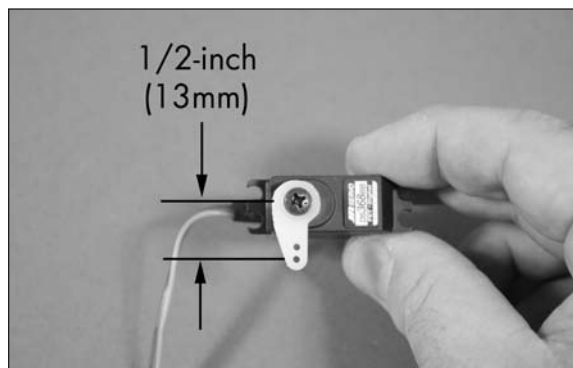

Etips

The rudder linkage will be connected to the hole in the servo horn 1/2-inch (13mm) from the center of the arm as illustrated in the photo above.

- 4. Remove the cover from the fuselage for the rudder servo. Set the cover aside until needed later in this section of the manual.

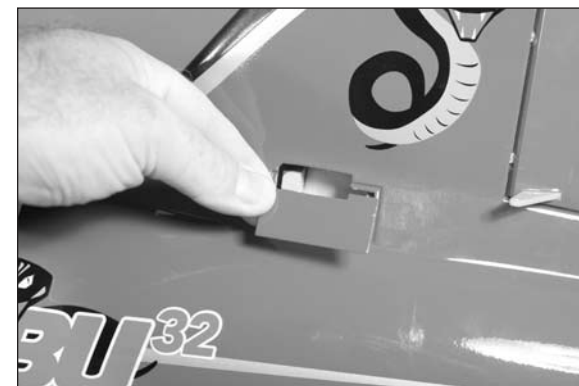

- 5. Use a #1 Phillips screwdriver to remove the two 2mm x 8mm self-tapping screws that secure the rudder servo plate to the rudder servo mounts. Set the screws and plate aside to be installed in the next step.

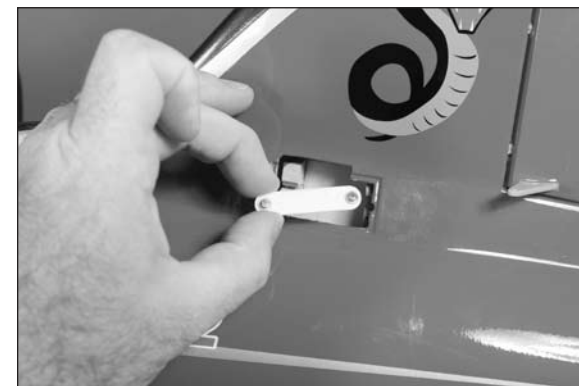

- 6. Place 2–3 drops of thin CA in each of the holes. This will harden the threads made by the screws making them more secure when the steering servo is installed.



- 7. Test fit the servo into the mounting blocks. Due to factory tolerances it may be necessary to shim the servo for a snug fit. If needed use tape on the sides and ends of the servo to make sure that it fits snugly in the blocks.

- 7. Place the rudder servo extension into the fuselage. The rudder servo can then be fit into the fuselage and slid into the rudder servo mounts. The servo is a tight fit, so work slowly when positioning the servo. Secure the rudder servo in the fuselage using the strap and screws removed in the previous step. Tighten the screws using a #1 Phillips screwdriver.



- 8. Route the rudder servo lead through the fuselage and formers as shown. It will run through both formers and then come out over the top of the intakes into the front cockpit area.



- 9. Use a hobby knife with a #11 blade to trim two 1/4-inch (6mm) pieces from the silicone tubing.

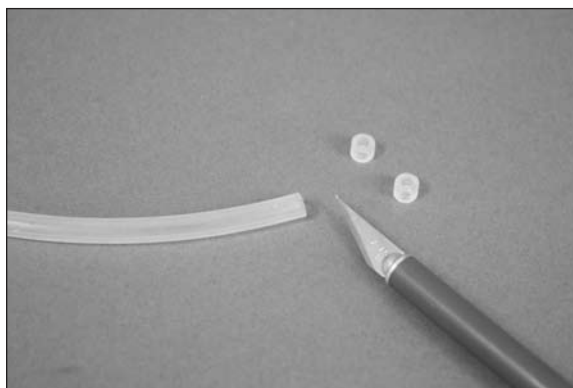

E-tips

Always use threadlock on metal-to-metal fasteners to prevent them from vibrating loose.

- 10. Slide the piece of silicone tubing on each of the metal clevises. Assemble the steering linkage by threading a 2mm nut and metal clevis on either end of the 2 1/4-inch (57mm) threaded rod as shown.



E-tips

Always use threadlock on metal-to-metal fasteners to prevent them from vibrating loose.

- 11. Remove the low-tack tape holding the rudder to the fin. Attach the linkage to the rudder and rudder servo. Make a slight bend in the linkage so it doesn't hit the fuselage when the rudder is at full throw. Adjust the linkage so the rudder is centered when the rudder servo is centered. Slide the silicone tubing over the forks of the clevises and tighten the 2mm nuts against the clevises to prevent them from moving.

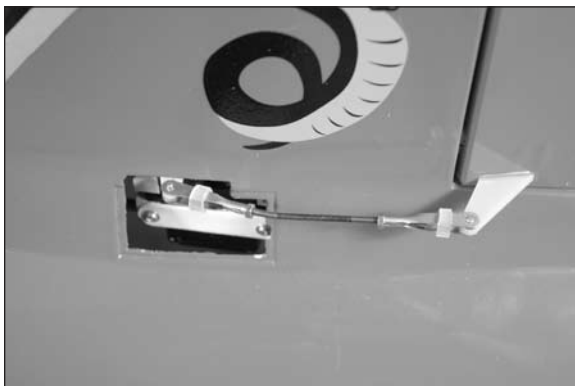

- 12. Use clear tape to secure the servo cover to the fuselage. Recheck the operation of the rudder servo to make sure it does not hit the cover during operation. Some final trimming of the cover may be needed for clearance of the servo arm.



Stabilizer Spar Installation

Required Parts

Fuselage Carbon stabilizer spar (2)
 Stabilizer assembly (right and left)
 3mm x 15mm socket head screw (4)
 Silicone tubing

Required Tools and Adhesives

15-minute epoxy Mixing cup
 Paper towels Mixing stick
 Epoxy brush Rubbing alcohol
 Ruler Medium grit sandpaper
 Petroleum jelly Felt-tipped pen
 Low-tack tape Hobby knife with #11 blade
 Ball driver: 2.5mm (long), 9/64-inch

E-tips

If you do not have a long 2.5mm ball driver you can use a dowel and some tape to extend the handle.

- ○ 1. Slide the carbon stabilizer spar into the fuselage. Use two 3mm x 15mm socket head screws to secure the spar in position. Make any necessary adjustments to the opening in the fuselage so the screws align without binding. Note that the spar will angle to the bottom of the fuselage when installed in the correct direction.



E-tips

Cut a 1/2-inch (13mm) piece of silicone tubing and slide it on a 2.5mm hex wrench. The 3mm screw can then be placed in the tubing and against the hex wrench so the screw can be easily installed to secure the landing gear.



- ○ 2. Use a felt-tipped pen to mark the edge of the fuselage on the spar.

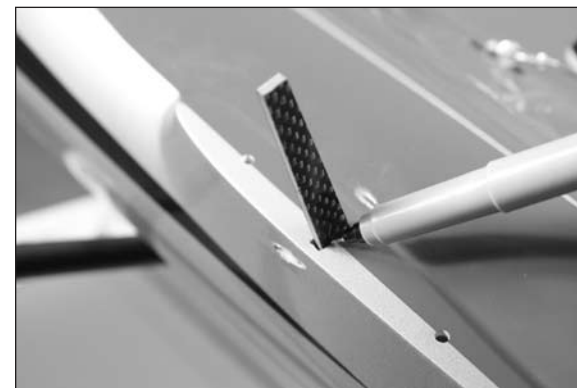

- ○ 3. Remove the spar from the fuselage using a 2.5mm hex wrench. Check the fit of the spar in the stabilizer. It should easily slide in up to the line drawn on the spar in the previous step.

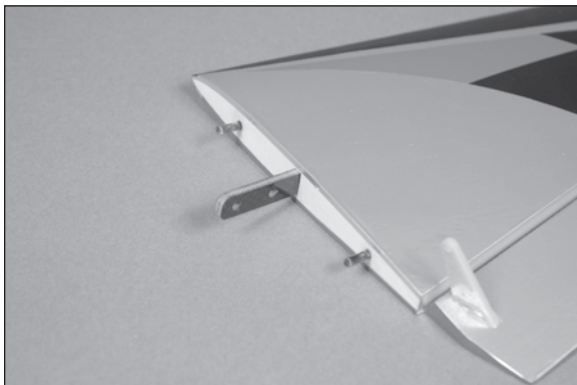

- ○ 4. Check the fit of the stabilizer on the fuselage. It must fit tightly against the fuselage when the screws that secure the spar to the fuselage. If the spar fits into the stabilizer and fuselage without any problems, the fit of the stabilizer to the fuselage should be perfect.



- 5. Repeat steps 1 through 4 to check the fit of the remaining stabilizer to the fuselage. Both stabilizers should be positioned on the fuselage at this time.

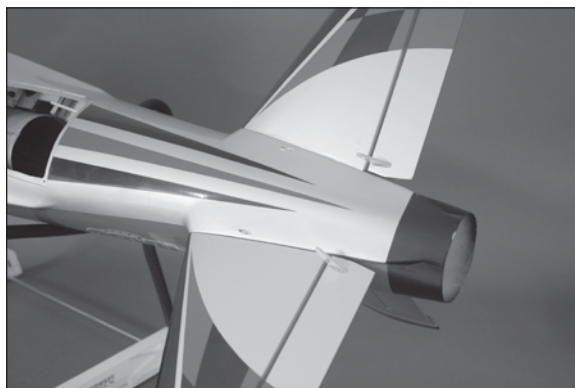

- 6. Attach the wing panels to the fuselage using a 9/64-inch hex wrench. Stand back 8–10 feet (2–3 meters) and check that the stabilizers are positioned an equal distance from the wing. If not, the spars may need to be sanded slightly to correct any alignment issues.

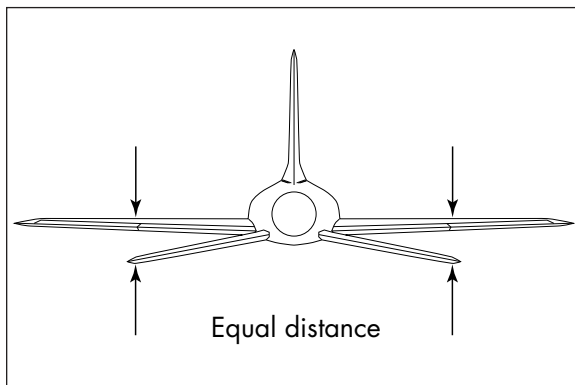

- ○ 7. Remove the spar from the fuselage and stabilizer. Use medium grit sandpaper to lightly sand the spar where it will fit into the stabilizer. Sand both the front and back of the spar.

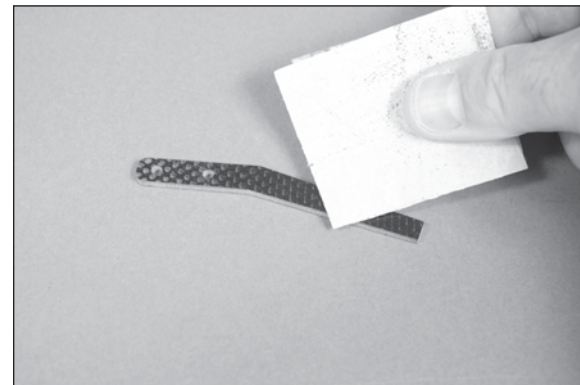

- ○ 8. Apply a thin coat of petroleum jelly to the fuselage around the spar socket. This will keep you from accidentally gluing the stabilizer to the fuselage during the following procedure.



Etips

Before mixing any epoxy, make sure to read through and understand the following steps. It is important to perform these steps before the epoxy fully cures.

- ○ 9. Mix 1/2 ounce (15mL) of 15-minute epoxy. Apply the epoxy to the spar pocket of the stabilizer using a mixing stick.

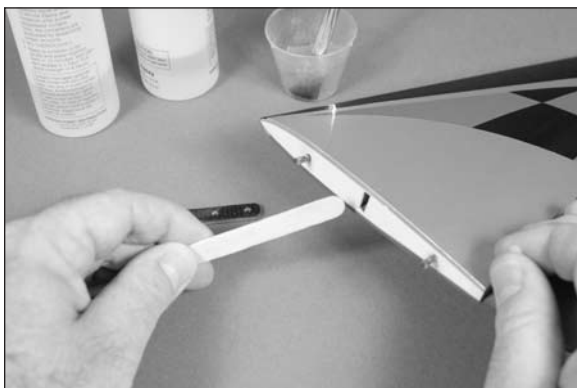

- ○ 10. Use an epoxy brush to apply epoxy to the front, back, top and bottom of the spar where it fits into the stabilizer.



- ○ 11. Slide the spar into the stabilizer, making sure it is oriented correctly. Use a paper towel and rubbing alcohol to remove any excess epoxy from the stabilizer and spar.



E-tips

Epoxy will ooze out from the spar pocket of the stabilizer. If epoxy does not ooze out, not enough epoxy was used to glue the spar into the stabilizer.

- ○ 12. Before the epoxy cures, slide the stabilizer into position against the fuselage. Keep the stabilizer tight against the fuselage until the epoxy fully cures. Install the 3mm x 15mm socket head screws that secure the spar to the fuselage using a 2.5mm hex wrench. Use low-tack tape to hold the stabilizer in position until the epoxy has cured. Make sure to check the alignment of the stabilizer to the wing while the epoxy is curing to make sure the stabilizer has not moved.



- 13. Repeat steps 7 through 12 to install the remaining stabilizer to the fuselage.
- 14. Once the epoxy has fully cured use a 9/64-inch hex wrench to remove the wing panels from the fuselage so it is easier to maneuver on your workbench. Remove the elevators and clean any petroleum jelly residue from the fuselage and stabilizers using rubbing alcohol and a paper towel. Reattach the elevators to the fuselage.

Elevator Servo Installation

Required Parts

Fuselage assembly Servo with hardware (MC35) (2)
Y-harness Metal clevis (4)
2mm nut (4) Silicone tubing
Pushrod support base (2)
Pushrod support standoff, L1 and L2
Pushrod support standoff, R1 and R2
2mm x 8mm self-tapping screw (4)
Pushrod wire, 16¹/₄-inch (412mm) (2)

Required Tools and Adhesives

String Scissors
Thin CA Medium CA
CA accelerator Pliers
Hobby knife with #11 blade
Phillips screwdriver: #1

- ○ 1. Prepare the elevator servo by installing the rubber grommets and brass eyelets as shown in the radio or servo instructions. Center the elevator servo using the radio system. Use side cutters to remove any arms from the horn that may interfere with the operation of the servo.

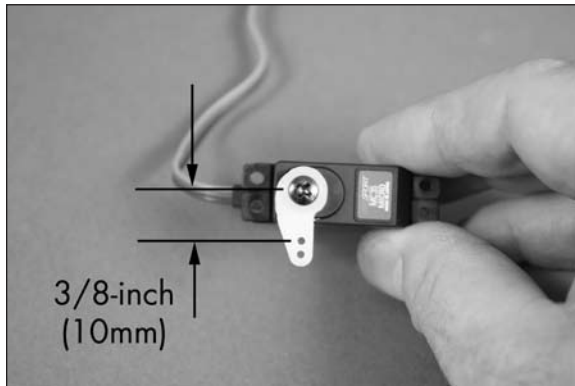

E-tips

The elevator linkage will be connected to the hole in the servo that is 3/8-inch (10mm) from the center of the arm as illustrated in the photo above.

- 2. Repeat step 1 to prepare a second elevator servo. Note the servos will be identical.

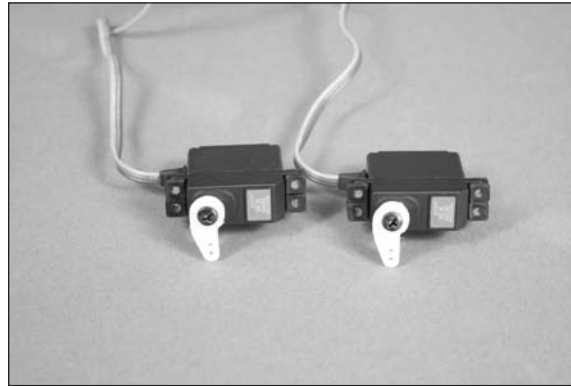

E-tips

The screws for the elevator servo will go in at a slight angle so they can be accessed by the screwdriver.

- ○ ○ 3. Use a #1 Phillips screwdriver to thread a servo mounting screw into the mounting holes for the elevator servo. Remove the screw after cutting the threads in the plywood.



- ○ ○ 4. Place 2–3 drops of thin CA in each of the holes. This will harden the threads made by the screws making them more secure when the elevator servo is installed.



- ○ 5. Install the elevator servo in the fuselage using the hardware provided with the servo and a #1 Phillips screwdriver. The servo output faces the front of the fuselage. Guide the lead from the servo over the top of the intake and to the front of the fuselage.



- 6. Repeat steps 3 and 4 using a 2mm x 8mm self-tapping screw and a #1 Phillips screwdriver to prepare and harden the holes for the pushrod support assembly. Allow the CA to soak into the wood for a minute, then apply CA accelerator to make sure the CA has fully cured before proceeding as the supports will need to be moved slightly when installing the fan assembly.

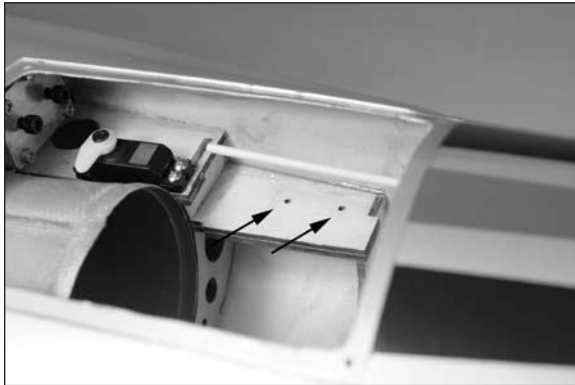

- 7. Assemble the pushrod support using a pushrod support base and the L1 and L2 support standoffs. Note the position of the base in relationship to the standoffs. L2 will be on the side of the base that is closer to the mounting hole. They must be positioned correctly so the pushrod aligns with the elevator servo.

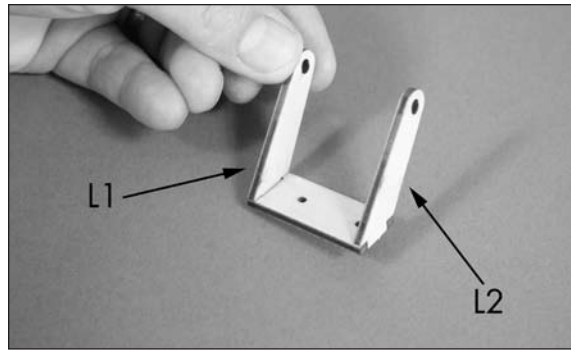
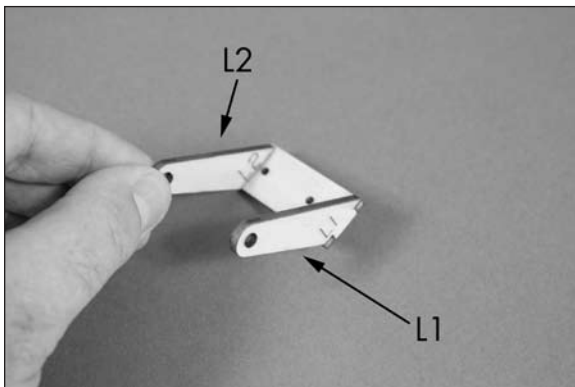

- 8. Slide the supports on the elevator pushrod tube. Secure the support assembly in the fuselage using two 2mm x 8mm self-tapping screws and a #1 Phillips screwdriver. Use a hobby knife and #11 blade to trim the pushrod tube as close to the forward support as possible.



- 9. Use a hobby knife with a #11 blade to trim two 1/4-inch (6mm) pieces from the silicone tubing.



Etips

Always use threadlock on metal-to-metal fasteners to prevent them from vibrating loose.

- 10. Slide the piece of silicone tubing on a metal clevis. Thread a 2mm nut then the clevis on one end of a 16 1/4-inch (412mm) threaded pushrod as shown.

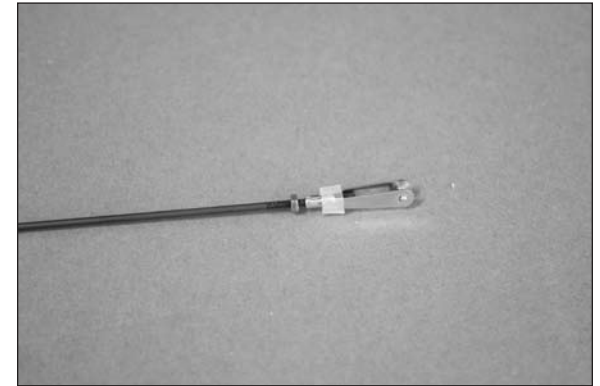

- 11. Slide the pushrod into the tube from the rear of the fuselage.



- ○ 12. Slide the piece of silicone tubing on a metal clevis. Thread a 2mm nut then the clevis on the end of the pushrod inside the fuselage. Connect the clevis to the elevator servo horn.



Etips

It may be necessary to remove the horn from the elevator servo using a #1 Phillips screwdriver to attach the clevis to the horn. Make sure the servo is centered and the horn is perpendicular to the servo as shown in step 1 when reattaching the horn to the servo.

- ○ 13. Remove the tape that holds the elevator to the stabilizer. Connect the clevis to the elevator control horn. Adjust the clevises so the elevator is centered when the elevator servo is centered using the radio system. Use pliers to tighten the 2mm nuts against the clevises and slide the silicone tubing over the forks of the clevis to prevent the clevis from opening accidentally in flight.



Etips

Always use threadlock on metal-to-metal fasteners to prevent them from vibrating loose.

- 14. Repeat steps 3 through 13 to install the remaining elevator servo and linkage. The pushrod support brace will be assembled using the base and R1 and R2 standoffs as shown in the following photos. R2 will be positioned so it is near the hole closest to the edge of the base.

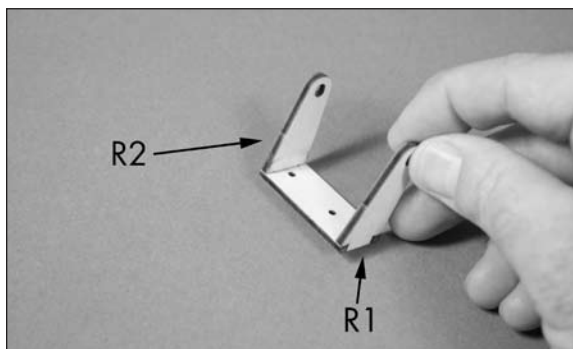
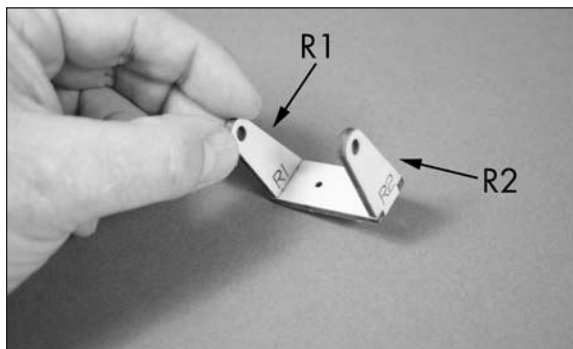

- 15. Secure the Y-harness to the elevator servo leads using string or a commercially available connector.



Fan Installation

Required Parts

Fan assembly	Fuselage assembly
Exhaust tube	Fan fairing
2mm x 6mm machine screw (2)	
3mm x 10mm self-tapping screw (4)	

Required Tools and Adhesives

Thin CA	Phillips screwdriver: #1
Low-tack tape	Pin vise
Pencil	Felt-tipped pen
Ruler	Hobby scissors
Low-tack tape	Drill bit: 5/64-inch (2mm)

- 1. Locate the fan unit. View the fan unit and use the drawing provided to determine the top and bottom of the fan. There will be a label on the top of the fan unit to help identify the top. This label was not available during the production of this manual. A piece of low-tack tape on the top of the fan is shown so the top can easily be determined during assembly.

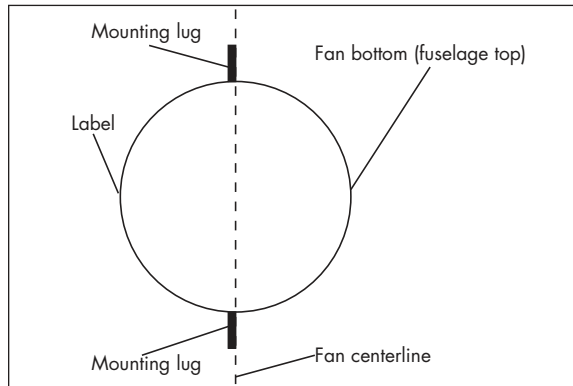

- 2. Pass the wires through the fan fairing.

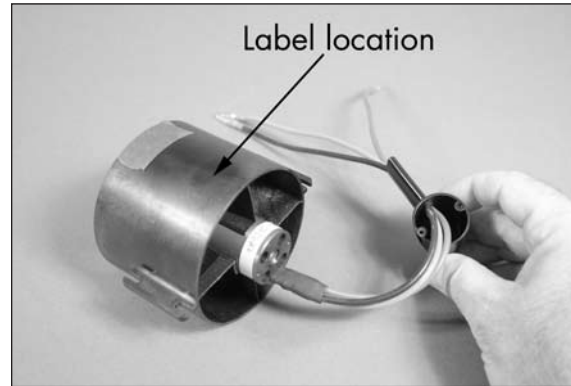

- 3. Use two 2mm x 6mm machine screws and a #1 Phillips screwdriver to attach the fan fairing to the motor. Note that the fairing faces to the bottom of the fan unit.



- 4. Use a ruler and pencil to draw two lines along the outside of the fan housing to indicate the location of the fan fairing.

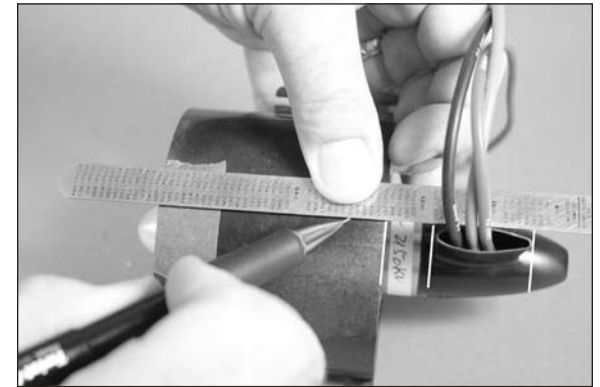

- 5. Remove the fan fairing from the motor using a #1 Phillips screwdriver. Slide the exhaust tube over the fan unit. The seam on the tube will be toward the bottom of the fan. Use low-tack tape to tape the tube to the fan unit temporarily. Transfer the lines on the housing to the exhaust tube using a felt-tipped pen and ruler. Also make a mark at the edge of the fan housing to locate the position of the tube on the housing.

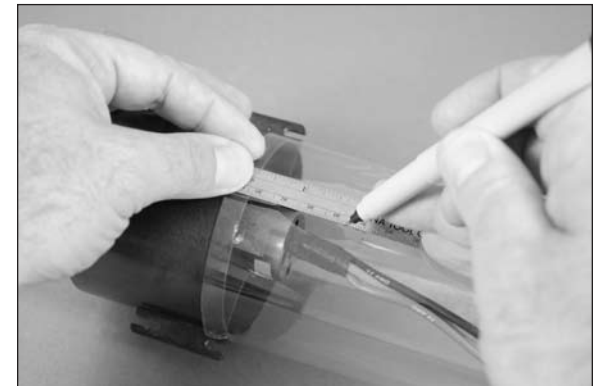

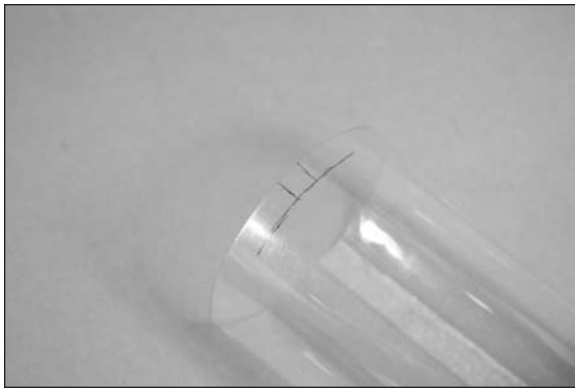

- 6. Measure back 1/2-inch (13mm) and 1⁵/₈-inch (42mm) from where the edge of the fan housing fits in the tube. Use these lines and those that aligned with the fan fairing to draw a rectangle on the tube. Carefully draw an airfoil shape that matches the fan fairing in the rectangle.

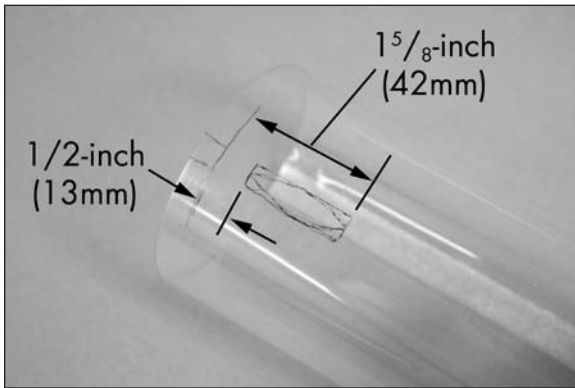

- 7. Use hobby scissors to trim the exhaust tube for the fan fairing. Slot the exhaust tube so it can be slid over the fan fairing.

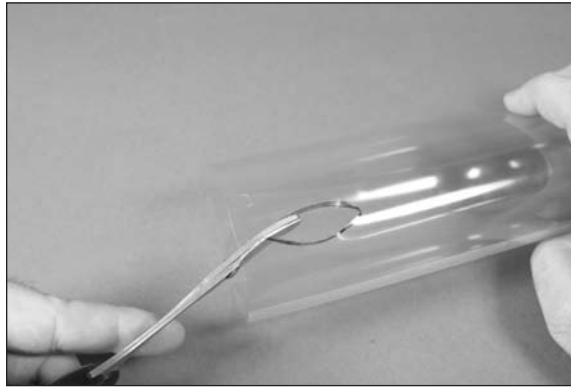

- 8. Repeat step 2 and 3 to reattach the fan fairing to the motor. Check the fit of the exhaust tube on the fan unit. It may be necessary to trim the opening slightly using hobby scissors.

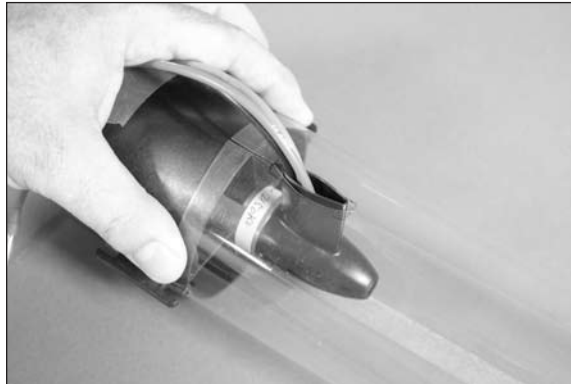

- 9. Fit the fan housing into the fuselage. You may need to remove the elevator servo horns and loosen the screws holding the pushrod supports to fit the fan into the fuselage. Slide the fan forward to make sure it is fully inserted into the intake.

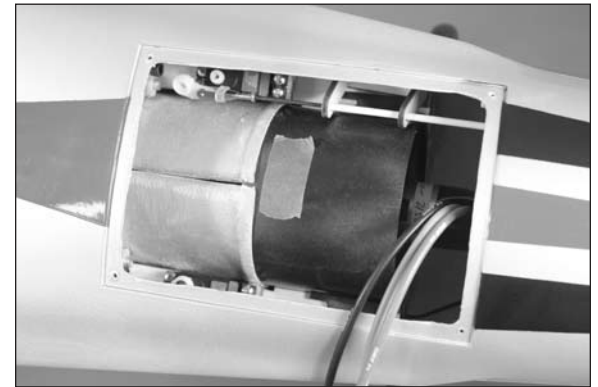

- 10. Use a pin vise and 5/64-inch (2mm) drill bit to drill the four holes for the fan mounting screws. Make sure to drill the holes against the tabs of the housing so the fan does not slide forward or aft in the fuselage.

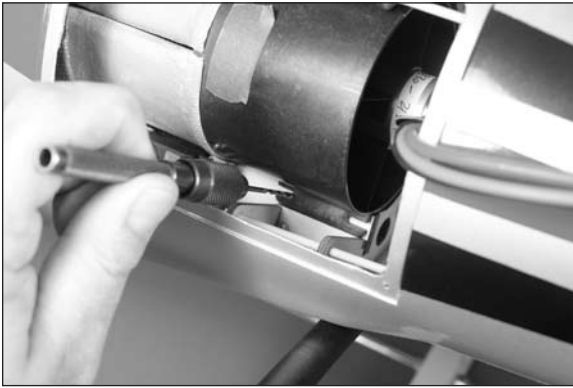

E-tips

You can also mount the pin vise in a drill so it can reach down inside the fuselage saving some time when drilling the holes.



- 11. Use a #1 Phillips screwdriver to thread a 3mm x 10mm self-tapping screw into the four holes for mounting the fan unit.



- 12. Place 2-3 drops of thin CA in each hole to harden the surrounding wood. This hardens the wood, making the screws more secure.

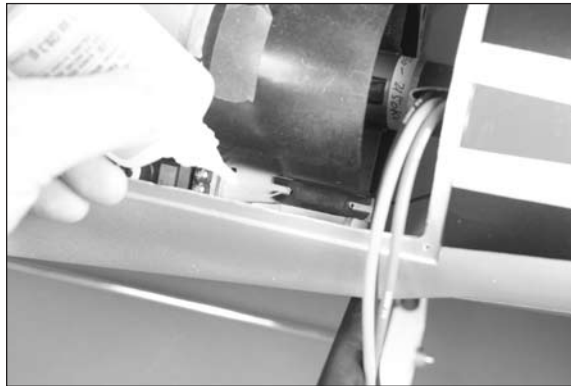

- 13. Secure the fan unit in the fuselage using four 3mm x 10mm self-tapping screws. Tighten the screws using a #1 Phillips screwdriver.



- 14. Install the elevator servo horn and pushrod support if it was moved to install the fan housing in the fuselage. The tape can also be removed from the bottom of the fan housing at this time.

Exhaust Tube and Speed Control Installation

Required Parts

Fuselage assembly	Exhaust tube
Clear tape	Fan access hatch
Speed control	Hook and loop tape

Required Tools and Adhesives

Hobby scissors	Felt-tipped pen
Hemostats	

- 1. Carefully roll or fold the exhaust tube into the shape shown below. It is made of a durable clear plastic and will not be harmed by doing so.

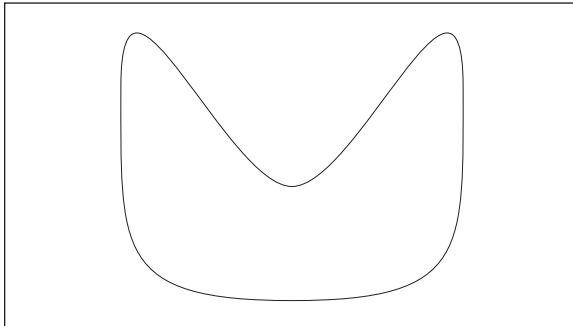

- 2. Slide the exhaust tube into the fuselage, with the wider end of the tube entering the fuselage from the rear. It will “pop” open when it has been inserted fully into the fuselage.



- 3. Position the exhaust tube so it overlaps onto the fan assembly.

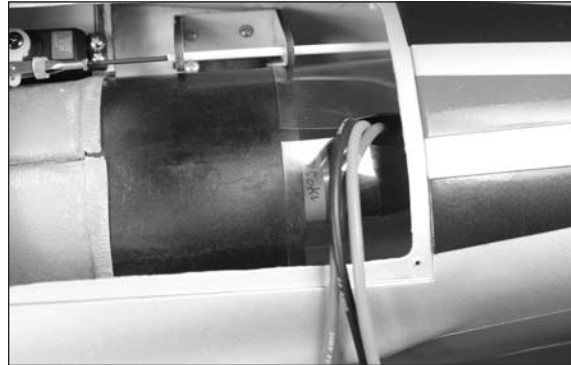

- 4. Use clear tape to secure the thrust tube to the fan housing.

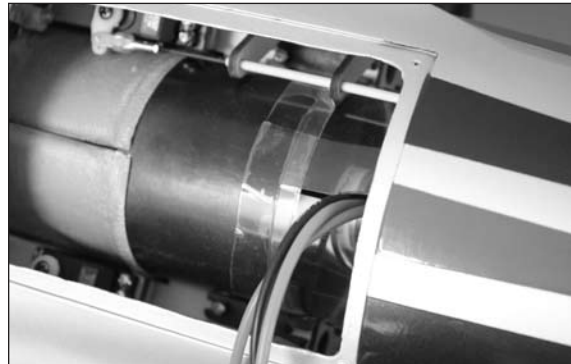

- 5. Use clear tape at the bottom of the thrust tube to secure the tube at the rear of the fuselage.

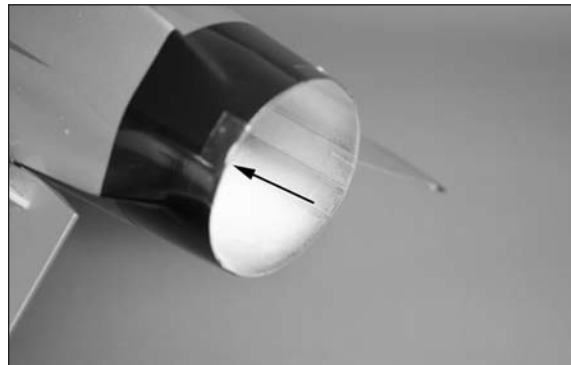

- 6. Route the leads from the motor through the oval opening at the bottom of the former near the intake ducts. Use clear tape to tape the leads to the fan housing and intake duct so they don't move and interfere with the operation of the elevator servos.



- 7. Cut a piece of hook and loop tape to fit the back of the speed control using scissors. Apply the tape to the speed control as shown.

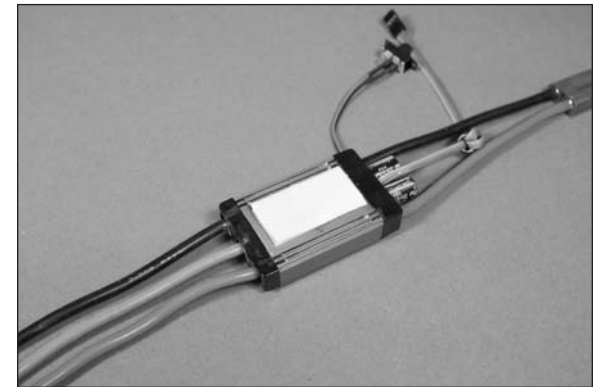

Etips

Matching the colors between the ESC and motor when they are connected results in the correct motor direction if using all E-flite components.

- 8. Connect the leads from the speed control to the leads from the motor. Use a pair of hemostats to hold the leads from the motor while you are plugging the leads from the controller into them.



- 9. Remove the backing from the hook and loop tape to mount the speed control inside the fuselage. Make sure to secure the switch inside the fuselage where it can be easily accessed using double-sided tape.



Etips

Make sure to set the cutoff voltage of the speed control to match the cell count of the battery.

Receiver Installation - 6-channel Receiver

Required Parts

Fuselage assembly Harness from retract assembly
 6-inch (152mm) Y-harness (2) (flaps, ailerons)
 3-inch (76mm) Y-harness (steering/rudder)
 3-inch (76mm) servo extension (flaps)
 6-inch (152mm) servo extension (retracts)
 9-inch (228mm) servo extension (retracts)
 12-inch (304mm) servo extension (2) (flaps, ailerons)

Required Tools and Adhesives

Scissors String

Note: The following section is for installing the receiver in the Habu 32 for a 5- or 6-channel operation depending on if you are using retracts or not. This is the basic setup for the Habu 32 using Y-harnesses for all control surfaces.

- 1. Prepare the aileron harness by securing a 12-inch (304mm) extension to a 6-inch (152mm) Y-harness using string or a commercially available connector. The 12-inch (304mm) extension will plug into the aileron channel of the receiver.



- 2. Prepare the flap harness by securing a 12-inch (304mm) extension to a 6-inch (152mm) Y-harness using string or a commercially available connector. The 12-inch (304mm) extension will plug into the aileron channel of the receiver. Secure a 3-inch (76mm) extension to one side of the Y-harness using string or a commercially available connector. Make sure to mark the flap harness so it can be easily identified from outside the fuselage when installing the wing panels.



- 3. Insert the flap and aileron harnesses through the hole in front of the elevator servo and into the fuselage. The leads will exit toward the top of the fuselage above the intake. Secure the leads using tape or tie-wraps to keep them from interfering with the operation of the elevator servos.



- 4. (Optional Retracts) Prepare the retract harness by securing a 6-inch (152mm) and 9-inch (228mm) extension to the retract harness using string or a commercially available connector. This will plug into the retract channel of the receiver.

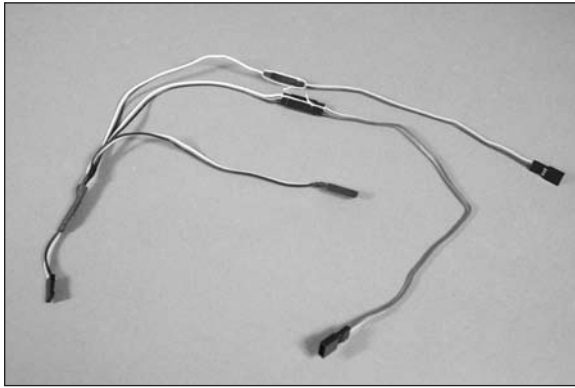

- 5. Plug the leads for the elevator, ailerons, flaps, and speed control into the receiver at this time. Plug a Y-harness into the rudder channel of the receiver for the rudder and steering. All the extensions should now be connected to the receiver. Use the following to connect the extensions to the receiver:

6-CHANNEL RECEIVER ASSIGNMENTS:

Throttle	Speed Control
Aileron	Ailerons (harness from step 1)
Elevator	Elevator (Y-harness)
Rudder	Rudder and Nose Gear Steering (Y-Harness)
Gear	Gear (optional) (harness from step 4)
Aux 1	Flaps (harness from step 2)

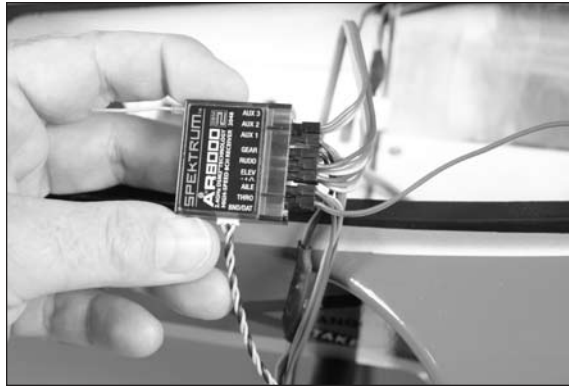

Etips

Programs for the Habu using the DX8 are available for download on the Spektrum website.

- 6. Use scissors to cut a small piece of hook and loop tape. Use the tape to secure the receiver in the fuselage.

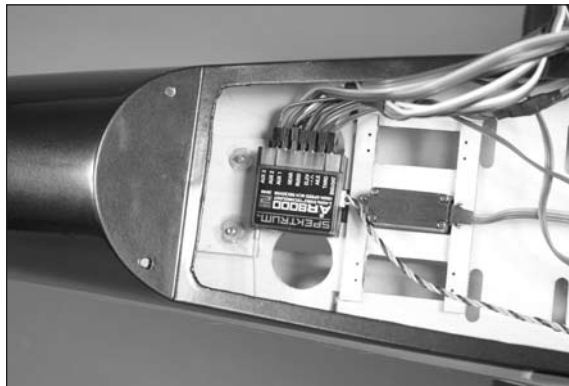

- 7. Use scissors to cut a small piece of hook and loop tape. Use the tape to secure the remote receiver in the fuselage.

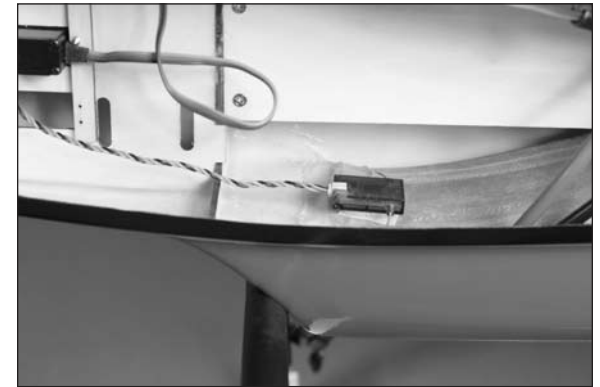

- 8. Route the lead for the retracts through the fuselage. Use a pair of hemostats to hold the leads from the motor while you are plugging the leads from the controller into them. Routing it through the tray the nose gear is mounted to and along the bottom of the fuselage will keep the installation clean. Secure any loose leads with tie wraps (not included).



Etips

Use a #1 Phillips screwdriver to remove the nose gear cover so there is better access for routing the retract leads.

Receiver Installation - 8-channel Receiver

Required Parts

Fuselage assembly Harness from retract assembly
 6-inch (152mm) Y-harness
 3-inch (76mm) servo extension (flaps)
 6-inch (152mm) servo extension (retracts)
 9-inch (228mm) servo extension (retracts)
 12-inch (304mm) servo extension (flaps)
 18-inch (457mm) servo extension (2) (ailerons)

Required Tools and Adhesives

Scissors String

Note: The following section covers the installation of a 7- or 8-channel receiver. This will allow you to optimize and fine-tune the feel of the Habu 32 by using separate aileron channels and also a separate channel for the nose gear steering. This will allow for a more custom feel to each pilot. It will also allow you to set the nose gear up for separate trimming and a high and low rate switch.

- 1. Prepare the flap harness by securing a 12-inch (304mm) extension to a 6-inch (152mm) Y-harness using string or a commercially available connector. The 12-inch (304mm) extension will plug into the aileron channel of the receiver. Secure a 3-inch (76mm) extension to one side of the Y-harness using string or a commercially available connector. Make sure to mark the flap harness so it can be easily identified from outside the fuselage when installing the wing panels.

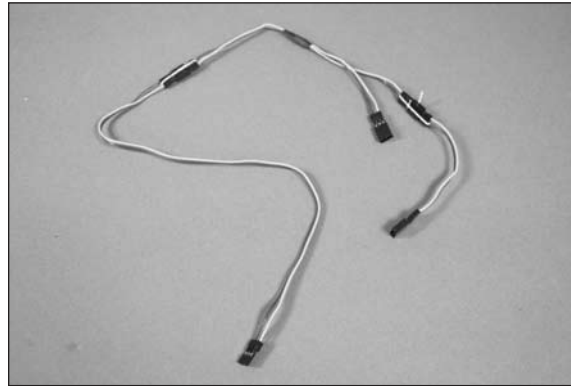

- 2. Insert the flap harnesses and one of the 18-inch (457mm) extensions through the hole in front of the elevator servo and into the fuselage on the right side as shown. Run the other 18-inch (457mm) servo extension inside the hole on the left side of the fuselage. The leads will exit toward the top of the fuselage above the intake. Secure the leads using tape or tie-wraps to keep them from interfering with the operation of the elevator servos.

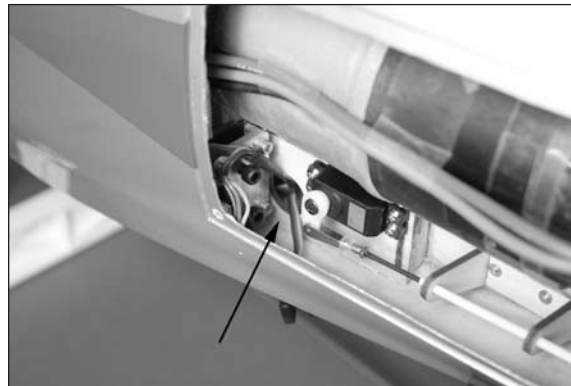

E-tips

The 18-inch (457mm) servo extensions reach the wing roots for the ailerons and keep the excess wire to a minimum. If you will be taking the Habu 32 apart often, connect a 3-inch (76mm) servo extension to each of the 18-inch (457mm) servo extensions to ease assembly.

- 3. (Optional Retracts) Prepare the retract harness by securing a 6-inch (152mm) and 9-inch (228mm) extension to the retract harness using string or a commercially available connector. This will plug into the retract channel of the receiver.

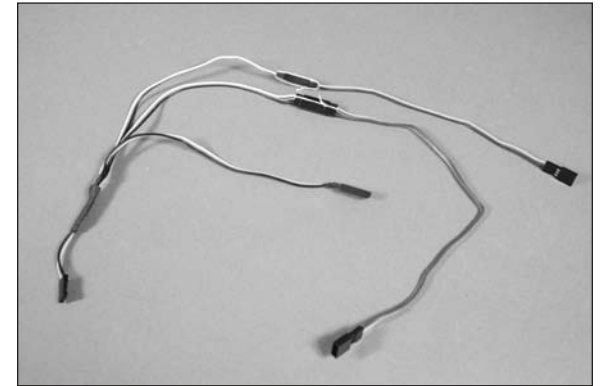

- 4. Plug the leads for the rudder, elevator, ailerons, flaps, nose wheel servo and speed control into the receiver at this time. All the extensions should now be connected to the receiver.

8-CHANNEL RECEIVER ASSIGNMENTS FOR DX8:

Throttle	Speed Control
Aileron	Right Aileron
Elevator	Elevators (Y-harness)
Rudder	Rudder
Gear	Flaps (harness from step 1)
Aux 1	Left Aileron
Aux 2	Gear (optional) (harness from step 3)
Aux 3	Nose Gear Steering

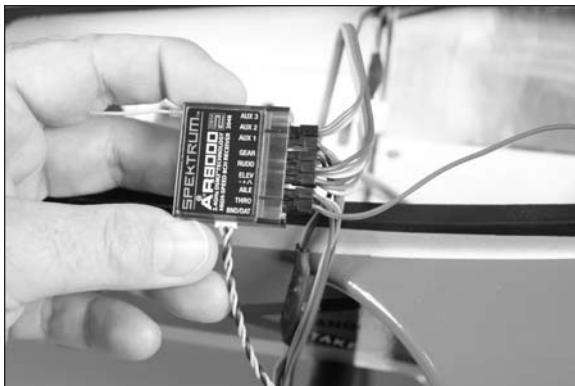

Etips

Programs for the Habu using the DX8 are available for download on the Spektrum website.

- 5. Use scissors to cut a small piece of hook and loop tape. Use the tape to secure the receiver in the fuselage.

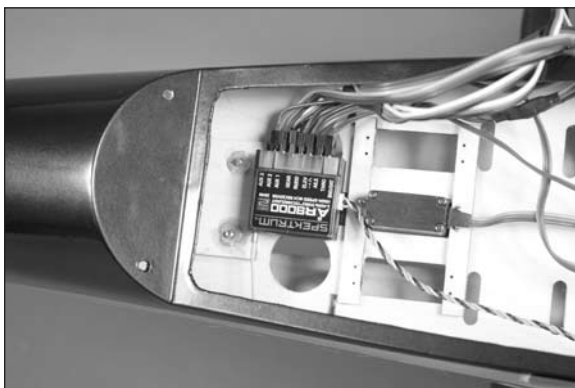

- 6. Use scissors to cut a small piece of hook and loop tape. Use the tape to secure the remote receiver in the fuselage.



- 7. Route the lead for the retracts through the fuselage. Routing it through the tray the nose gear is mounted to and along the bottom of the fuselage will keep the installation clean. Secure any loose leads with tie wraps (not included).



Etips

Use a #1 Phillips screwdriver to remove the nose gear cover so there is better access for routing the retract leads. Replace after routing the leads.

Motor Battery Installation

Required Parts

Fuselage assembly Hook and loop tape
 Motor battery Hook and loop strap
 Fan cover

Required Tools and Adhesives

Scissors Phillips screwdriver: #1

- 1. Apply the hook and loop tape to the bottom of the battery. This will keep the battery from sliding in the fuselage which could change the center of gravity.



- 2. Apply the mating hook and loop tape to the battery tray in the fuselage.

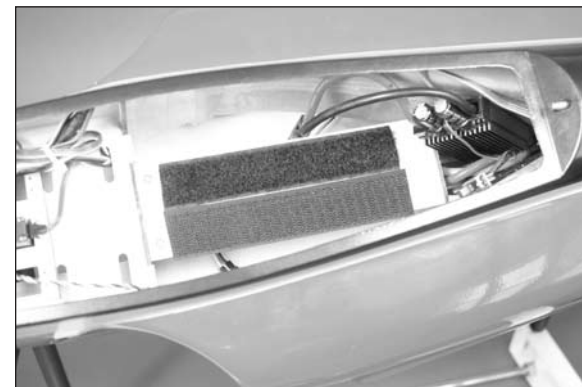

- 3. Secure the battery in the fuselage using the hook and loop strap. Make sure the strap is not pinching any of the servo leads on the bottom side of the battery tray.



Canopy Assembly

Required Parts

Canopy Cockpit interior
Pilot (optional) (PKZ4414)

Required Tools and Adhesives

Hobby scissors Clear tape

- 1. Locate the cockpit interior and use hobby scissors to trim the interior along the inscribed line. Trim the interior a little outside the line so it can be trimmed to fit to the canopy.

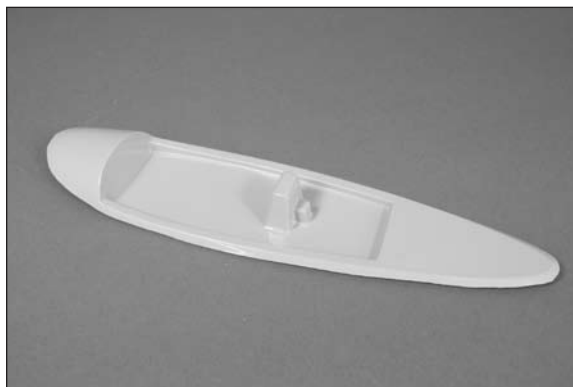

- 2. Place the interior in the canopy. It may be necessary to bend the interior slightly to fit past the canopy frame.



- 3. Use clear tape to secure the interior inside the canopy.

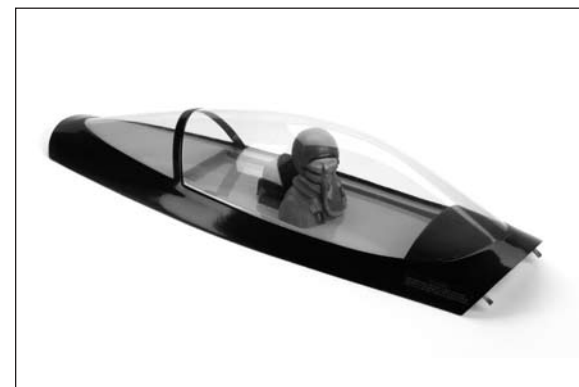
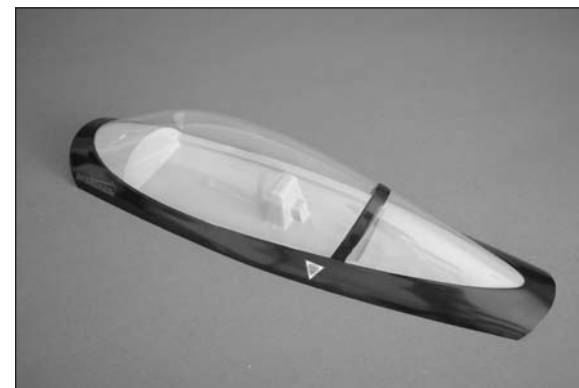

E-tips

You can add more detail to the Habu 32 cockpit by painting parts of the cockpit with different colors so it looks more realistic.

Center of Gravity

Required Parts

Assembled airframe

Required Tools and Adhesives

Balancing stand Felt-tipped pen



CAUTION: Do not inadvertently skip this step or property damage and injury could occur.

When balancing your model, adjust the motor battery as necessary so the model is level or slightly nose down. This is the correct balance point for your model. You should find the CG to be very close with the battery installed as shown in this manual. Mark the location of the battery on the battery tray using a felt-tipped pen so it can be returned to this position if it is removed from your model.

After the first flights, the CG position can be adjusted for your personal preference.

- 1. Attach the wings to the fuselage following the procedure outlined earlier in this manual. Attach the fan cover to the fuselage using the four 2mm x 8mm self-tapping screws removed earlier and a #1 Phillips screwdriver.



- 2. The recommended Center of Gravity (CG) location for your model is $3^{15}/_{16}$ to $4^{1}/_{2}$ inches (100 to 115mm) back from the leading edge of the wing as shown with the battery pack installed. Mark the location of the CG on the top of the wing with a felt-tipped pen.

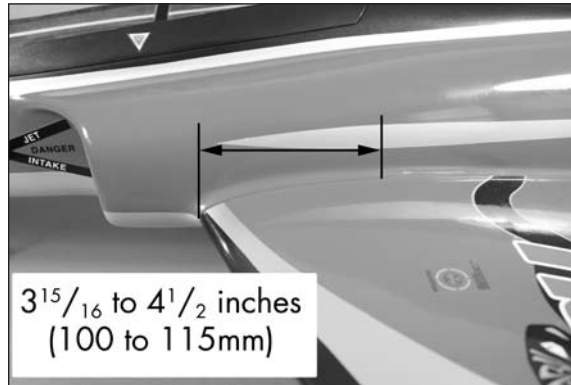

- 3. When balancing your model, support the plane inverted at the marks made on the top of the wing with your fingers or a commercially available balancing stand. This is the correct balance point for your model. Make sure your model is assembled and ready for flight before balancing.

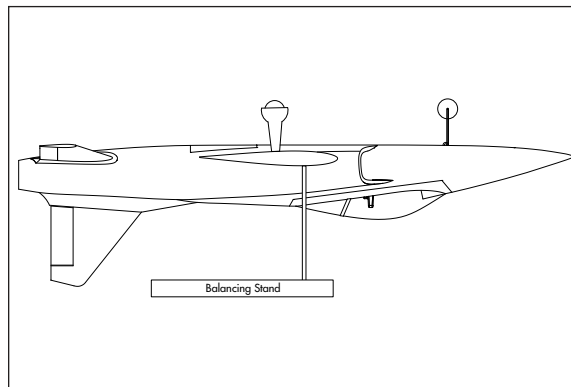

Etips

If you have installed retracts, balance your model with the gear down.

Control Throws

- 1. Turn on the transmitter and receiver of your model. Check the movement of the rudder using the transmitter. When the stick is moved right, the rudder should also move right. Reverse the direction of the servo at the transmitter if necessary.
- 2. Check the movement of the elevator with the radio system. Moving the elevator stick toward the bottom of the transmitter makes the airplane elevator move up.
- 3. Check the movement of the ailerons with the radio system. Moving the aileron stick right makes the right aileron move up and the left aileron move down.
- 4. Use a ruler to adjust the throw of the elevator, ailerons and rudder. Adjust the position of the pushrod at the control horn to achieve the following measurements when moving the sticks to their endpoints.

Note: Use caution with high rates on the elevator and ailerons. High rates are only used for snap and spin aerobatic maneuvers. Middle rates are suggested for takeoff and landings. Low rates are suggested for standard flight maneuvers. If your radio only has the option for two rates, use the middle and low rates.

Aileron

High Rate

Up: 11mm 25% Expo
Down: 11mm 25% Expo

Mid Rate

Up: 8mm 15% Expo
Down: 8mm 15% Expo

Low Rate

Up: 7mm 10% Expo
Down: 7mm 10% Expo

Elevator

High Rate		
Up:	12mm	18% Expo
Down:	12mm	24% Expo
Mid Rate		
Up:	10mm	10% Expo
Down:	10mm	12% Expo
Low Rate		
Up:	8mm	5% Expo
Down:	8mm	8% Expo

Rudder

High Rate		
Right:	20mm	12% Expo
Left:	20mm	12% Expo
Mid Rate		
Right:	18mm	8% Expo
Left:	18mm	8% Expo
Low Rate		
Right:	15mm	5% Expo
Left:	15mm	5% Expo

Flap

Mid/Take-Off	11mm
Flap Full/Landing	25mm

Flap-Elevator Mix

Mid/Take-Off	1mm down
Flap Full/Landing	2mm down

E-tips

The Habu does not always require full flaps for landing. We recommend using full flaps for landings in no wind or light headwind situations. Use half flaps for landings in strong headwinds or crosswinds.

E-tips

Measurements are taken at the inner or widest point on the control surface.

These are general guidelines measured from our own flight tests. You can experiment with higher rates to match your preferred style of flying.

E-tips

Travel Adjust and Sub-Trims are not listed and should be adjusted according to each individual model and preference.

E-tips

We highly recommend re-binding the radio system once all the control throws are set. This will keep the servos from moving to their endpoints until the transmitter and receiver connect.

Preflight

Check Your Radio

Before going to the field, be sure your batteries are fully charged per the instructions included with your radio. Charge the transmitter and motor battery for your airplane. Use the recommended charger supplied with your particular radio system, following the instructions provided with the radio. In most cases, the radio should be charged the night before going out flying.

Before each flying session, be sure to range check your radio. See your radio manual for the recommended range and instructions for your radio system. Each radio manufacturer specifies different procedures for their radio systems. Next, run the motor. With the model securely anchored, check the range again. The range test should not be significantly affected. If it is, don't attempt to fly! Have your radio equipment checked out by the manufacturer.

Double-check that all controls (aileron, elevator, rudder and throttle) move in the correct direction.

Check the radio installation and make sure all the control surfaces are moving correctly (i.e., the correct direction and with the recommended throws).

Check all the control horns, servo horns, and clevises to make sure they are secure and in good condition.

Flying Your Model

Now that you have finished your Habu 32 and it's ready to go, make one final check of a few things first.

- Is the main battery fully charged? Is the transmitter fully charged?
- Are dual rates and travel adjustments set for the first flight?

Remember the Habu 32 is very responsive and it is highly recommended that you take off with middle rates and then switch to low rates right after takeoff. Has the center of gravity been verified? Has the timer been set? We recommend that the timer be set for 3 minutes on the first flight. After 3 minutes of flight this will still give you a good safety margin for a few landing approaches. The Habu 32 will consistently give you 4+ minutes of high-speed flight. If you use power management 6+ minutes is easily achieved.

If the answer to all of these questions is yes, then you are ready for that first flight. Only fly the Habu 32 at a sanctioned flying field as it is not a park flyer. Turn on the transmitter, plug in the flight battery, and turn on the switch for the radio. Check all control surfaces and basic motor operation. Check the motor at full throttle. Pick the model up and cycle the retracts. If everything is working properly you are ready for flight.

Taxi the model onto the runway. Make a few taxi tests and get the nose gear steering adjusted so the model rolls straight down the runway. For your first flight leave the flaps up on takeoff until you are familiar with the Habu 32. Set the dual rates to the middle position. If you have set the rudder and steering up separately then you can also set the nose gear for a lower rate.

Takeoff

While applying power slowly steer with the rudder to keep the model straight. The Habu 32 should accelerate quickly. As the model gains flight speed, you will want to rotate when you feel comfortable. The Habu 32 will climb out at a nice angle of attack.

Trimming and Flight Characteristics

After takeoff, gain some altitude and retract the landing gear and switch to low rates. Climb to a safe altitude and begin to trim the model. Once you have the model trimmed you will want to get an idea of the

flight quality with the flaps down and the model slowed down. Slow the model down to a little below half power and drop the flaps to the middle position. Check the trim again and also note if the model needs any up or down elevator compensation. At this time you may also need to come back up on the power a little. Now try full flaps and note any other trim changes at this time. The Habu 32 will fly very nicely with full flaps added and is very predictable in this configuration. Drop the landing gear and switch back to middle rates at this time to check the trim once again in landing configuration. Once you are happy with this, retract the gear, pull the flaps up, and switch back to low rates and start to enjoy the performance of the Habu 32. You will find the model tracks very well through all aspects of flight. From high-speed passes, inverted flight, loops, and point rolls, you will be flying like a jet pilot in no time. Get a feel for all dual rates. The high rates are only used for snap and spin maneuvers. Middle rates are for takeoff and landings. Low rates are for normal and precision flight.

Landing

Remember to keep an eye on the radio timer. After 3 minutes on the first flight it's time to drop the flaps, the retracts, and set the rates in the middle and start shooting a few approaches with the Habu 32. To set up for landing, drop the flaps and retracts, set the rates to the middle position and enter the downwind pattern for landing. If you are landing in higher winds or cross winds use middle flaps instead of full flaps. Adjust power to slow the plane down but keep flying speed. As you roll onto final approach manage the power and begin to pull the nose up. The Habu 32 has a very nice approach and decent rate. You will find that with the nose slightly high you can control the final approach descent with power management. The key to a great landing is to manage the power and elevator all the way to the ground and set down lightly on the main landing gear. After a few flights you will find the Habu can be set down lightly on the mains and you can hold the nose wheel off balancing the model on the mains till it slows and gently settle the nose. We hope you enjoy flying the E-flite Habu 32

Happy Landings!

Range Test Your Radio

Before each flying session, and especially with a new model, it is important to perform a range check. It is helpful to have another person available to assist during the range check. If you are using a Spektrum transmitter, please refer to your transmitter's manual for detailed instructions on the range check process.

- 1. With the model resting on the ground, stand 30 paces (approximately 90 feet) away from the model.
- 2. Face the model with the transmitter in your normal flying position. Be sure the throttle is in the full down position and plug the flight battery into the speed control.
- 3. As you move the controls, watch to be sure the airplane's motor and controls operate smoothly. You should have total control of the model at 30 paces (90 feet).
- 4. If control issues exist, call the appropriate Horizon Product Support office (see page 43) or go to horizonhobby.com to find a local Spektrum distributor in your country for service if using a Spektrum radio system.

Daily Flight Checks

- 1. Check the battery voltage of the transmitter battery. Do not fly below the manufacturer's recommended voltage. To do so can crash your aircraft.

E-tips

When you check these batteries, ensure you have the polarities correct on your expanded scale voltmeter.

- 2. Check all hardware (linkages, screws, nuts, and bolts) prior to each day's flight. Be sure that binding does not occur and that all parts are properly secured.
- 3. Ensure all surfaces are moving in the proper manner.
- 4. Perform a ground range check before each day's flying session.
- 5. Prior to starting your aircraft, turn off your transmitter, then turn it back on. Do this each time you start your aircraft. If any critical switches are on without your knowledge, the transmitter alarm will sound a warning at this time.
- 6. Check that all trim levers are in the proper location.
- 7. All servo pigtails and switch harness plugs should be secured in the receiver. Make sure the switch harness moves freely in both directions.

Warranty and Repair Policy

WARRANTY PERIOD

Exclusive Warranty- Horizon Hobby, Inc., (Horizon) warranties that the Products purchased (the "Product") will be free from defects in materials and workmanship at the date of purchase by the Purchaser.

LIMITED WARRANTY

Horizon reserves the right to change or modify this warranty without notice and disclaims all other warranties, express or implied.

(a) This warranty is limited to the original Purchaser ("Purchaser") and is not transferable. REPAIR OR REPLACEMENT AS PROVIDED UNDER THIS WARRANTY IS THE EXCLUSIVE REMEDY OF THE PURCHASER. This warranty covers only those Products purchased from an authorized Horizon dealer. Third party transactions are not covered by this warranty. Proof of purchase is required for all warranty claims.

(b) Limitations- HORIZON MAKES NO WARRANTY OR REPRESENTATION, EXPRESS OR IMPLIED, ABOUT NON-INFRINGEMENT, MERCHANTABILITY OR FITNESS FOR A PARTICULAR PURPOSE OF THE PRODUCT. THE PURCHASER ACKNOWLEDGES THAT THEY ALONE HAVE DETERMINED THAT THE PRODUCT WILL SUITABLY MEET THE REQUIREMENTS OF THE PURCHASER'S INTENDED USE.

(c) Purchaser Remedy- Horizon's sole obligation hereunder shall be that Horizon will, at its option, (i) repair or (ii) replace, any Product determined by Horizon to be defective. In the event of a defect, these are the Purchaser's exclusive remedies. Horizon reserves the right to inspect any and all equipment involved in a warranty claim. Repair or replacement decisions are at the sole discretion of Horizon. This warranty does not cover cosmetic damage or damage due to acts of God, accident, misuse, abuse, negligence, commercial use, or modification of or to any part of the Product. This warranty does not cover damage due to improper installation, operation, maintenance, or attempted repair by anyone other than Horizon. Return of any Product by Purchaser must be approved in writing by Horizon before shipment.

DAMAGE LIMITS

HORIZON SHALL NOT BE LIABLE FOR SPECIAL, INDIRECT OR CONSEQUENTIAL DAMAGES, LOSS OF PROFITS OR PRODUCTION OR COMMERCIAL LOSS IN ANY WAY CONNECTED WITH THE PRODUCT, WHETHER SUCH CLAIM IS BASED IN CONTRACT, WARRANTY, NEGLIGENCE, OR STRICT LIABILITY. Further, in no event shall the liability of Horizon exceed the individual price of the Product on which liability is asserted. As Horizon has no control over use, setup, final assembly, modification or misuse, no liability shall be assumed nor accepted for any resulting damage or injury. By the act of use, setup or assembly, the user accepts all resulting liability.

If you as the Purchaser or user are not prepared to accept the liability associated with the use of this Product, you are advised to return this Product immediately in new and unused condition to the place of purchase.

Law: These Terms are governed by Illinois law (without regard to conflict of law principals).

Warranty Services

QUESTIONS, ASSISTANCE, AND REPAIRS

Your local hobby store and/or place of purchase cannot provide warranty support or repair. Once assembly, setup or use of the Product has been started, you must contact Horizon directly. This will enable Horizon to better answer your questions and service you in the event that you may need any assistance. For questions or assistance, please direct your email to productsupport@horizonhobby.com, or call 877.504.0233 toll free to speak to a Product Support representative. You may also find information on our website at www.horizonhobby.com.

INSPECTION OR REPAIRS

If this Product needs to be inspected or repaired, please use the Horizon Online Repair Request submission process found on our website or call Horizon to obtain a Return Merchandise Authorization (RMA) number. Pack the Product securely using a shipping carton. Please note that original boxes may be included, but are not designed to withstand the rigors of shipping without additional protection. Ship via a carrier that provides tracking and insurance for lost or damaged parcels, as Horizon is not responsible for merchandise until it arrives and is accepted at our facility. An Online Repair Request is available at www.horizonhobby.com <http://www.horizonhobby.com> under the Repairs tab. If you do not have internet access, please contact Horizon Product Support to obtain a RMA number along with instructions for submitting your product for repair. When calling Horizon, you will be asked to provide your complete name, street address, email address and phone number where you can be reached during business hours. When sending product into Horizon, please include your RMA number, a list of the included items, and a brief summary of the problem. A copy of your original sales receipt must be included for warranty consideration. Be sure your name, address, and RMA number are clearly written on the outside of the shipping carton.

Notice: Do not ship batteries to Horizon. If you have any issue with a battery, please contact the appropriate Horizon Product Support office.

WARRANTY INSPECTION AND REPAIRS

To receive warranty service, you must include your original sales receipt verifying the proof-of-purchase date. Provided warranty conditions have been met, your Product will be repaired or replaced free of charge. Repair or replacement decisions are at the sole discretion of Horizon.

NON-WARRANTY REPAIRS

Should your repair not be covered by warranty the repair will be completed and payment will be required without notification or estimate of the expense unless the expense exceeds 50% of the retail purchase cost. By submitting the item for repair you are agreeing to payment of the repair without notification. Repair estimates are available upon request. You must include this request with your repair. Non-warranty repair estimates will be billed a minimum of ½ hour of labor. In addition you will be billed for return freight. Horizon accepts money orders and cashiers checks, as well as Visa, MasterCard, American Express, and Discover cards. By submitting any item to Horizon for inspection or repair, you are agreeing to Horizon's Terms and Conditions found on our website under the Repairs tab.

UNITED STATES

(Electronics and engines)
Horizon Service Center
4105 Fieldstone Rd
Champaign, Illinois
61822 USA
877-504-0233

Online Repair Request visit:
www.horizonhobby.com/repairs

(All other products)
Horizon Product Support
4105 Fieldstone Rd
Champaign, Illinois
61822 USA
productsupport@horizonhobby.com
877-504-0233

UNITED KINGDOM

Horizon Hobby Limited
Units 1-4 Ployters Rd
Staple Tye
Harlow, Essex
CM18 7NS
United Kingdom
sales@horizonhobby.co.uk
+44 (0) 1279 641 097

GERMANY

Horizon Technischer Service
Hamburger Str. 10
25335 Elmshorn
Germany
service@horizonhobby.de
+49 4121 46199 66

FRANCE

Horizon Hobby SAS
14 Rue Gustave Eiffel
Zone d'Activité du Réveil Matin
91230 Montgeron
infofrance@horizonhobby.com
+33 (0) 1 60 47 44 70

Compliance Information for the European Union



INSTRUCTIONS FOR DISPOSAL OF WEEE BY USERS IN THE EUROPEAN UNION

This product must not be disposed of with other waste. Instead, it is the user's responsibility to dispose of their waste equipment by handing it over to a designated collection point for the recycling of waste electrical and electronic equipment. The separate collection and recycling of your waste equipment at the time of disposal will help to conserve natural resources and ensure that it is recycled in a manner that protects human health and the environment. For more information about where you can drop off your waste equipment for recycling, please contact your local city office, your household waste disposal service or where you purchased the product.

2010 Official Academy of Model Aeronautics Safety Code

A. GENERAL

A model aircraft is a non-human-carrying aircraft capable of sustained flight in the atmosphere. It may not exceed limitations of this code and is intended exclusively for sport, recreation and/or competition. All model flights must be conducted in accordance with this safety code and any additional rules specific to the flying site.

1. Model aircraft will not be flown:
 - (a) In a careless or reckless manner.
 - (b) At a location where model aircraft activities are prohibited.
2. Model aircraft pilots will:
 - (a) Yield the right of way to all man carrying aircraft.
 - (b) See and avoid all aircraft and a spotter must be used when appropriate. (AMA Document #540-D-See and Avoid Guidance.)
 - (c) Not fly higher than approximately 400 feet above ground level within three (3) miles of an airport, without notifying the airport operator.
 - (d) Not interfere with operations and traffic patterns at any airport, heliport or seaplane base except where there is a mixed use agreement.
 - (e) Not exceed a takeoff weight, including fuel, of 55 pounds unless in compliance with the AMA Large Model Aircraft program. (AMA Document 520-A)
 - (f) Insure the aircraft is identified with the name and address or AMA number of the owner on the inside or affixed to the outside of the model aircraft.
(This does not apply to model aircraft flown indoors).
 - (g) Not operate aircraft with metal-blade propellers or with gaseous boosts except for helicopters operated under the provisions of AMA Document #555.

(h) Not operate model aircraft while under the influence of alcohol or while using any drug which could adversely affect the pilot's ability to safely control the model.

(i) Not operate model aircraft carrying pyrotechnic devices which explode or burn, or any device which propels a projectile or drops any object that creates a hazard to persons or property.

Exceptions:

- Free Flight fuses or devices that burn producing smoke and are securely attached to the model aircraft during flight.
 - Rocket motors (using solid propellant) up to a G-series size may be used provided they remain attached to the model during flight. Model rockets may be flown in accordance with the National Model Rocketry Safety Code but may not be launched from model aircraft.
 - Officially designated AMA Air Show Teams (AST) are authorized to use devices and practices as defined within the Team AMA Program Document (AMA Document #718).
 - (i) Not operate a turbine-powered aircraft, unless in compliance with the AMA turbine regulations. (AMA Document #510-A).
3. Model aircraft will not be flown in AMA sanctioned events, air shows or model demonstrations unless:
 - (a) The aircraft, control system and pilot skills have successfully demonstrated all maneuvers intended or anticipated prior to the specific event.
 - (b) An inexperienced pilot is assisted by an experienced pilot.
 4. When and where required by rule, helmets must be properly worn and fastened. They must be OSHA, DOT, ANSI, SNELL or NOCSAE approved or comply with comparable standards.

B. RADIO CONTROL (RC)

1. All pilots shall avoid flying directly over unprotected people, vessels, vehicles or structures and shall avoid endangerment of life and property of others.
2. A successful radio equipment ground-range check in accordance with manufacturer's recommendations will be completed before the first flight of a new or repaired model aircraft.

3. At all flying sites a safety line(s) must be established in front of which all flying takes place (AMA Document #706-Recommended Field Layout):
 - (a) Only personnel associated with flying the model aircraft are allowed at or in front of the safety line.
 - (b) At air shows or demonstrations, a straight safety line must be established.
 - (c) An area away from the safety line must be maintained for spectators.
 - (d) Intentional flying behind the safety line is prohibited.
4. RC model aircraft must use the radio-control frequencies currently allowed by the Federal Communications Commission (FCC). Only individuals properly licensed by the FCC are authorized to operate equipment on Amateur Band frequencies.
5. RC model aircraft will not operate within three (3) miles of any pre-existing flying site without a frequency-management agreement (AMA Documents #922- Testing for RF Interference; #923-Frequency Management Agreement)
6. With the exception of events flown under official AMA Competition Regulations, excluding takeoff and landing, no powered model may be flown outdoors closer than 25 feet to any individual, except for the pilot and the pilot's helper(s) located at the flight line.
7. Under no circumstances may a pilot or other person touch a model aircraft in flight while it is still under power, except to divert it from striking an individual.
This does not apply to model aircraft flown indoors.
8. RC night flying requires a lighting system providing the pilot with a clear view of the model's attitude and orientation at all times.
9. The pilot of a RC model aircraft shall:
 - (a) Maintain control during the entire flight, maintaining visual contact without enhancement other than by corrective lenses prescribed for the pilot.
 - (b) Fly using the assistance of a camera or First-Person View (FPV) only in accordance with the procedures outlined in AMA Document #550.



© 2010 Horizon Hobby, Inc.
horizonhobby.com
www.e-fliterc.com

The Spektrum trademark is used with permission of Bachmann Industries, Inc.

E-flite, JR SPORT, DSM, DSM2 and UltraCote are trademarks or registered trademarks of Horizon Hobby, Inc.

All other trademarks, service marks and logos are the property of their respective owners.