

MANUAL

GOBLIN RAW 420 COMPETITION

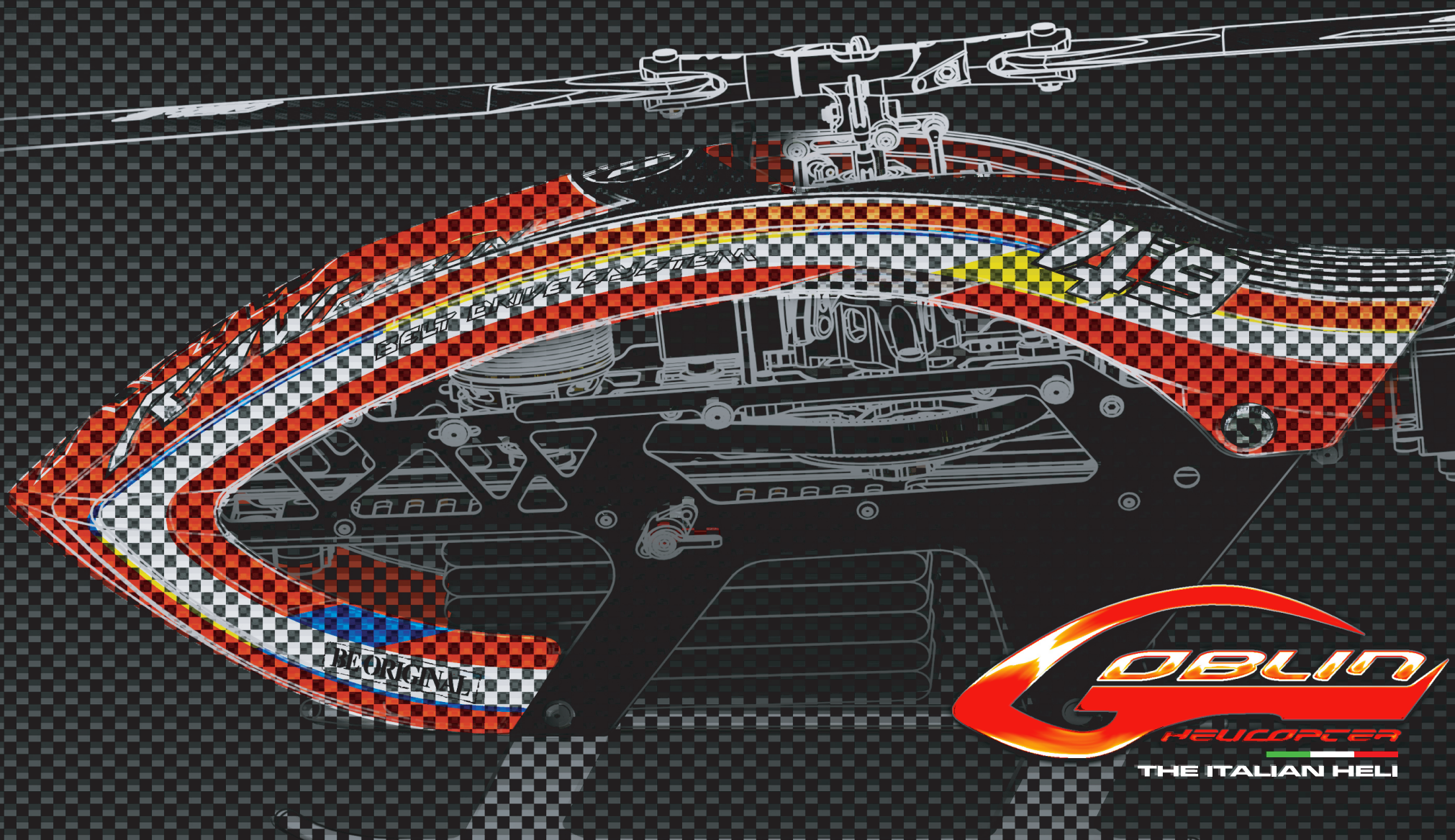

GAB HELI DIVISION

! Please read this user manual carefully, it contains instructions for the correct assembly of the model.
Please refer to the web site www.goblin-helicopter.com for updates and other important information.

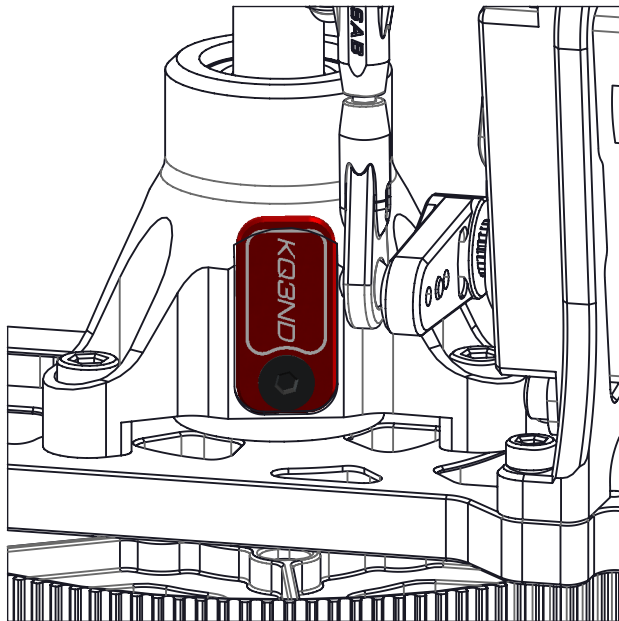

VERY IMPORTANT

You will find your serial number on the RED plate inside the bag for page 7.
Please take a moment to register your kit online via our web site at:

<http://www.goblin-helicopter.com>

It is extremely important that you take a moment to register your helicopter with us. This is the only way to ensure that you are properly informed about changes to your kit, such as upgrades, retrofits and other important developments. SAB Heli Division cannot be held responsible for any issues with your model and will not provide support unless you register your model.

The Serial number is also engraved on the Aluminum part.

Thank you for your purchase, we hope you enjoy your new Goblin helicopter!

SAB Heli Division

INDEX

1 – INTRODUCTION
2 – DISCLAIMER/WARRANTY
3 – NOTE FOR ASSEMBLY
4 – CARBON ROD ASSEMBLY
5 – FRAME GROUP ASSEMBLY
6 – MOTOR GROUP ASSEMBLY

7 – ASSEMBLY OF THE SWASH PLATE SERVOS
8 – TENSIONER ASSEMBLY
9 – ASSEMBLY OF THE MODULES
10 – HEAD ASSEMBLY
11 – TAIL GROUP ASSEMBLY
12 – TAIL BOOM ASSEMBLY
13 – INSTALLATION OF THE ESC/FBL

14 – INSTALLATION OF THE CANOPY
15 – INSTALLATION OF THE BATTERY
16 – IN FLIGHT
17 – MAINTENANCE
18 – CHECK LIST
19 – SPARE PARTS

GOBLIN RAW 420 TECHNICAL SPECIFICATIONS

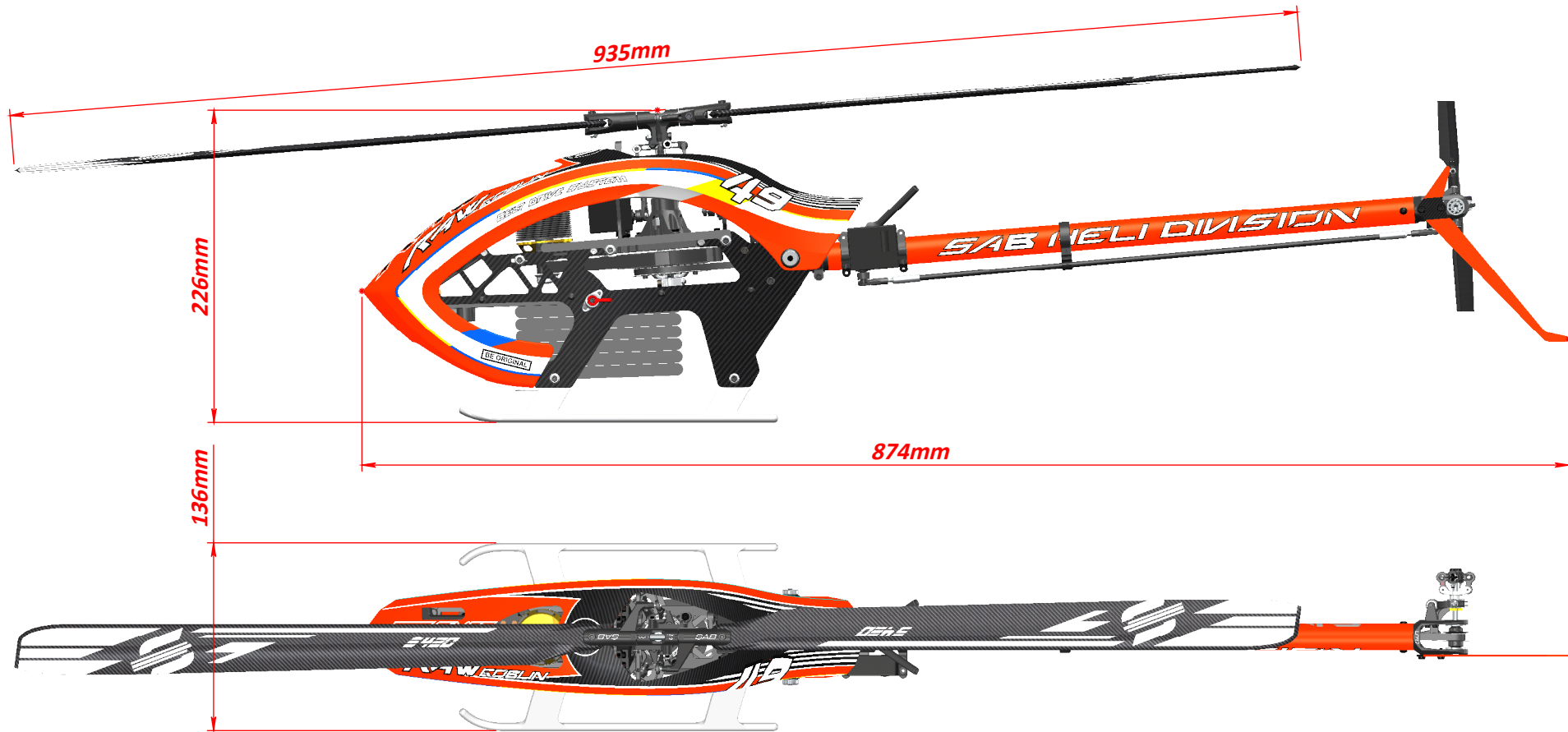

- **AIRFRAME weight:** 1000gr (with blades and motor, no battery and electronics).
- **Main rotor diameter:** 935mm (with 420 mm blades).
- **Main blade length:** 380 to 420 mm.
- **Tail rotor diameter:** 190 mm (with 70 mm tail blades).
- **Tail blade length:** 55 to 70 mm.

KIT Includes:

- 1 Motor Pulley 20T.
- 1 Battery Tray with straps and connectors.

- **Cyclic Servos:** Micro size 23 mm.
- **Tail Servo:** Mini size 35 mm.
- **Main Rotor Ratio :** 1 : 6,3 to 1 : 5.
- **Tail Rotor Ratio :** 4 : 1.
- **Maximum battery size:** 40x51x135mm.
- **Recommended battery:** 6S 2200/2700 mAh.
- **Recommended battery weight:** approximately 350-420gr.

- 420mm Main Blades.
- 70mm Tail Blades.

IMPORTANT SAFETY WARNING

- * This radio-controlled helicopter is not a toy. It should only be assembled, setup and operated by an adult.
- * This radio-controlled helicopter is a technically complex device which must be built and handled very carefully.
- * This radio-controlled helicopter must be built following these instructions. This manual provides the necessary information to correctly assemble the model.
- * Inexperienced pilots must be monitored by expert pilots.
- * A radio-controlled helicopter must only be used in open spaces without obstacles, and far enough from people to minimize the possibility of accidents or of injury.
- * A radio-controlled helicopter can behave in an unexpected manner, causing loss of control of the model, making it very dangerous.
- * Lack of care with assembly or maintenance can result in an unreliable and dangerous model.
- * Fly only in areas dedicated to the use of model helicopters.
- * Follow all control procedures for your radio frequency system >>>> Follow instructions and information provided by radio system, electronic speed controller, flight control system (gyro) manufacturers regarding safety, radio frequency control, setup/configuration, operations and other best practices.
- * It is necessary that you know your radio system well. Check all functions of the transmitter before every flight. >>>> It is crucial that you know your radio system, electronic speed controller and flight control system well. Properly check all their functions and connections before every flight.
- * The blades of the model rotate at a very high speed; be aware of the danger they pose and the damage they may cause.
- * Never fly in the vicinity of other people

ASSUMPTION OF RISK

Neither SAB Heli Division nor its agents have any control over the assembly, maintenance, and use of this product.

For this reason, SAB Heli Division is not responsible for injury, death or damage to people, things and / or to the product.

By assembling any component of this product, the user declares to have read and understood the following terms and conditions and agrees to be bound by them.

Failure to observe the above warnings and precautions may increase the risk of serious injury or death to yourself or surrounding people, damage to the product, or both.

SAB Heli Division shall not even be liable for special, indirect, or consequential damages, loss of profits or production or commercial loss in any way connected with the product, whether such claim is based in contract, warranty, negligence, or strict liability.

Further, in no event shall the liability of SAB Heli Division exceed the individual price of the Product on which liability is asserted.

By the act of use, setup, or assembly the user accepts all resulting liability.

Therefore, no responsibility can be traced back to the manufacturer.

You hereby agree to release SAB Heli Division from any responsibility or liability arising from the use of this product.

If you as the Purchaser or user are not prepared to accept the liability associated with the use of this Product, you are advised to return this Product immediately in new an unused condition to the place of purchase.

WARRANTY

SAB Heli Division reserves the right to change or modify this warranty without notice and disclaims all other warranties, express or implied.

(a) This warranty is limited to the original Purchaser ("Purchaser") and is not transferable. Replacement as provided under this warranty is the exclusive remedy of the purchaser. This warranty covers only those products purchased from an authorized SAB Heli Division dealer. Third party transactions are not covered by this warranty. Proof of purchase is required for warranty claims.

(b) Limitations

SAB Heli Division makes no warranty or representation, express or implied, about non infringement, merchantability, or fitness for a particular purpose of the product. The purchaser acknowledges that they alone have determined that the product will suitably meet the requirements of the purchaser's intended use.

(c) Purchaser Remedy

SAB Heli Division's sole obligation hereunder shall be that SAB Heli Division will, at its option, replace any Product determined by SAB Heli Division to be defective in the event of a defect, this is the Purchaser's exclusive remedy. Replacement decisions are at the sole discretion of SAB Heli Division. This warranty does not cover cosmetic damage or damage due to acts of God, accident, misuse, abuse, negligence, commercial use, or modification of or to any part of the Product. This warranty does not cover damage due to improper installation, operation, maintenance, or attempted repair by anyone.

ADDITIONAL COMPONENTS REQUIRED





- * Motor size: 3215-3220; 900-1000 Kv/V.
- *Speed controller: 6S capable, 60-80 Amps.
- *Batteries: 6S 2200/2700 mAh.
- *1 flybarless 3 axis control unit.
- *Radio power system.
- *3 Micro cyclic servos.
- *1 Mini tail rotor servo.
- *6 channel radio control system on 2.4 GHz.

TOOLS, LUBRICANTS, ADHESIVES

- *Generic pliers.
- *Hexagonal driver, size 1.5, 2, 2.5, 3mm.
- *4/5mm T-Wrench.
- *5.5mm Socket wrench (for M3 nuts).
- *8mm Hex fork wrench (for M5 nuts).
- *Medium threadlocker (SAB p/n HA116-S).
- *Strong retaining compound (SAB p/n HA115-S).
- *Spray lubricant (eg. Try-Flow Oil).
- *Synthetic grease (eg. Microlube 261).
- *Cyanoacrylate adhesive.
- *Pitch Gauge (for set-up).
- *Soldering equipment (for motor wiring).

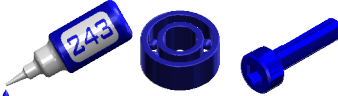
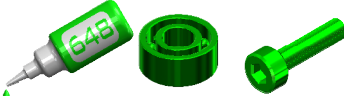
NOTES FOR ASSEMBLY

Please refer to this manual for assembly instructions for this model. Follow the order of assembly indicated. The instructions are divided into chapters, which are structured in a way that each step is based on the work done in the previous step. Changing the order of assembly may result in additional or unnecessary steps. Use thread lockers and retaining compounds as indicated. In general, each bolt or screw that engages with a metal part requires thread lock. It is necessary to pay attention to the symbols listed below:

| | | |
|---|--|--|
|  <p>Important</p> |  <p>Blue screw and blue bearing in the illustration means you need to use: Thread Locker Medium Strength (SAB HA116-S)</p> |  <p>Green screw and Green bearing in the illustration means you need to use: Retaining compound (SAB HA115-S)</p> |
|  <p>Indicates that for this assembly phase you need materials that are: BOX xxx, BAG xxx.</p> |  <p>Use CA Glue</p> |  <p>Use Proper Lubricant</p> |

INSIDE THE MAIN BOX THERE ARE:

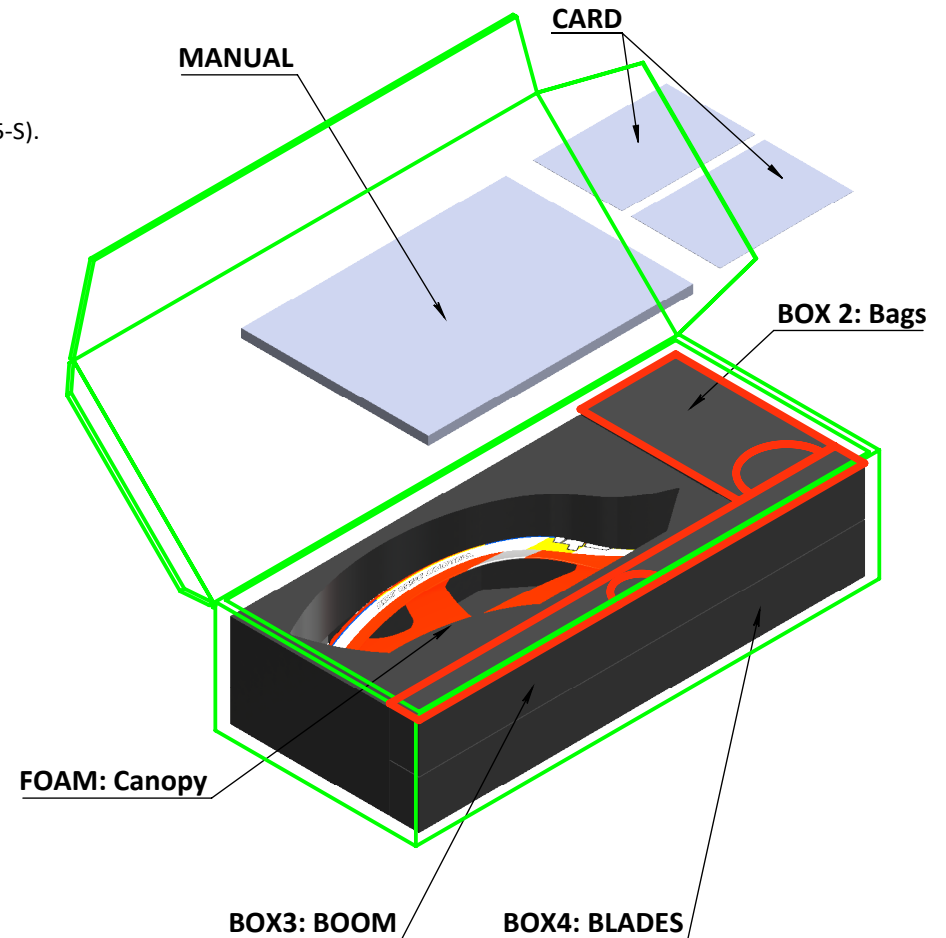

The assembly process is described in the following chapters. Each chapter provides you with the box, bag and/or foam numbers you will need for that chapter. The information is printed in a black box in the upper corner of the page.

BOX 2, BAG FOR PAGE 5

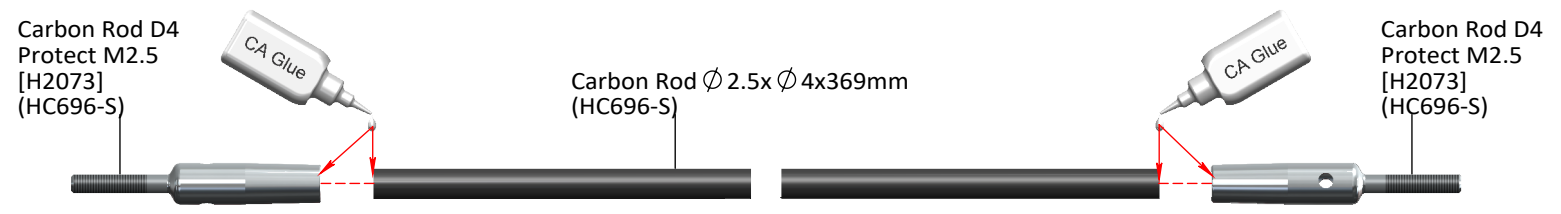

BEARING SUPPORT ASSEMBLY (H1473-S)

Already Assembled With Loctite

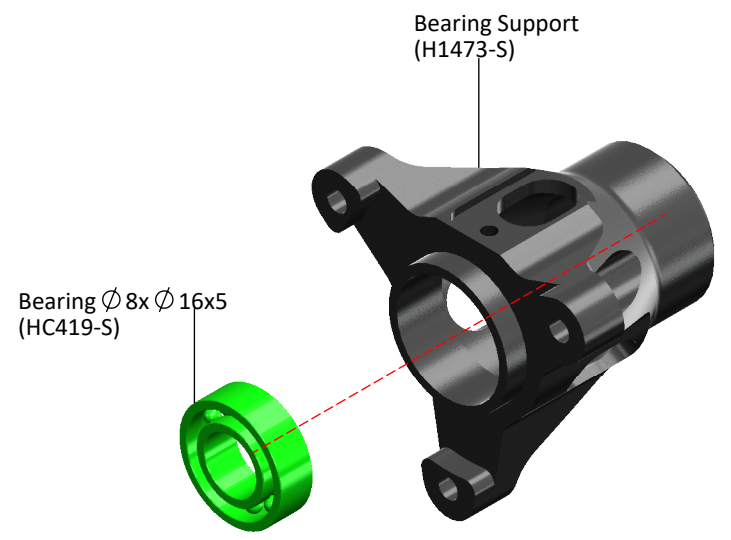

MAIN PLATE ASSEMBLY (H2023-S)

Already Assembled With Loctite

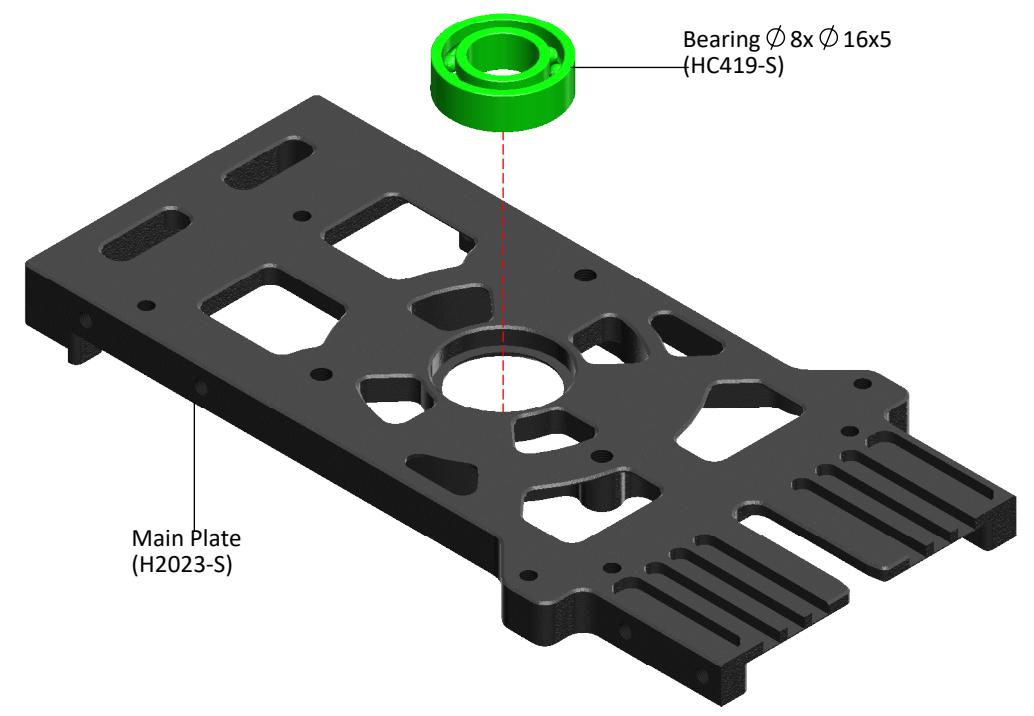

MAIN SHAFT ASSEMBLY

HUB SIDE

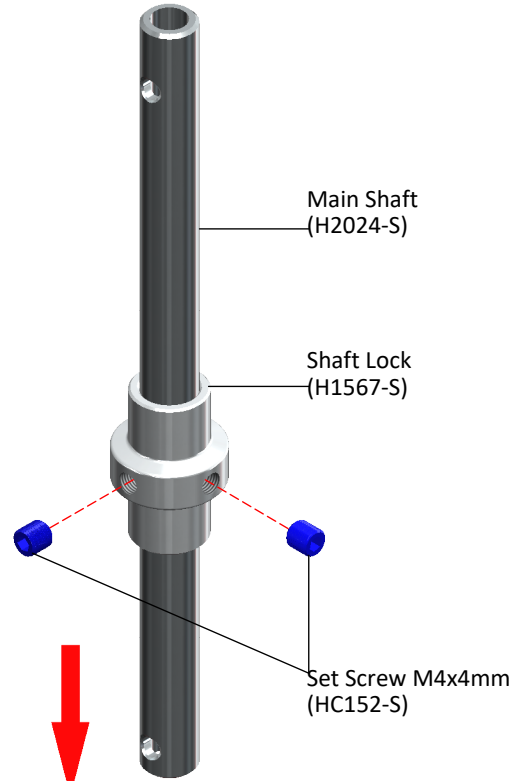

PULLEY SIDE

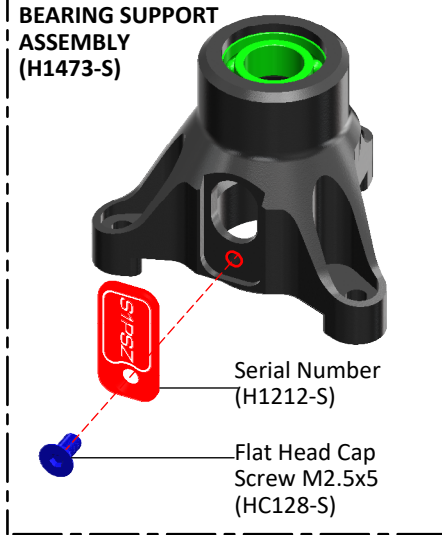
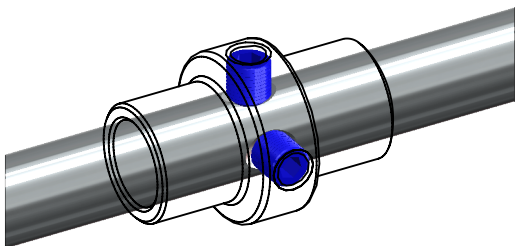

Socket Head Cap Screw M3x10mm (HC056-S)

Shims
 $\varnothing 8 \times \varnothing 12 \times 0,1\text{mm}$
 (HC462-S)

Tighten the three M3 screws. After tightening, check the axial play of the main shaft. It is possible to reduce any axial play by adding shims. **IMPORTANT:** Carefully check to make sure you can turn the main shaft freely. If you feel too much friction, you have used too many shims, you can remove a shim until the shaft turns freely.

Boom Clamp Mount (H1452-S)

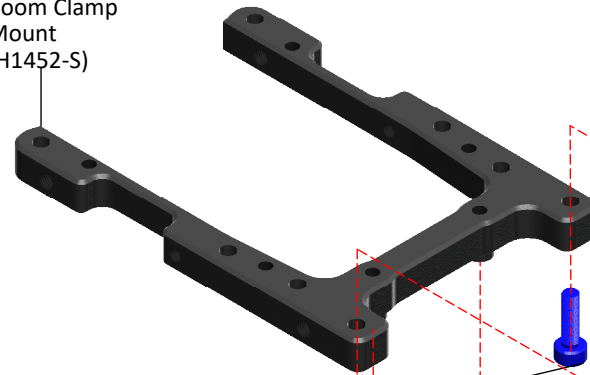

Socket Head Cap Screw M2.5x8mm (HC020-S)

Tail Belt Idler Assembly (H0575-S)

Socket Head Cap Screw M2.5x10mm (HC022-S)

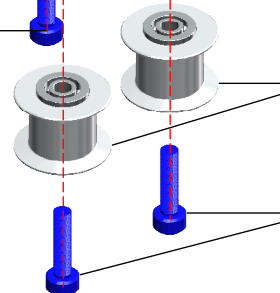

Main Plate Assembly (H2023-S)

MAIN SHAFT ASSEMBLY

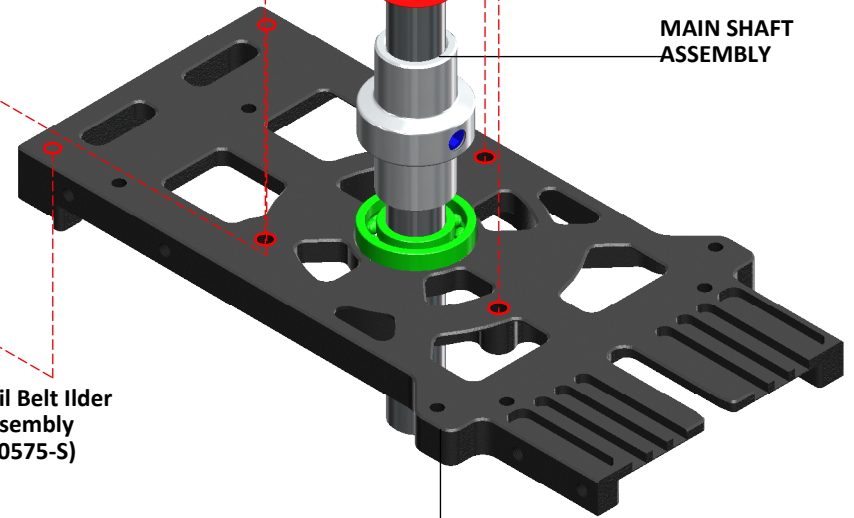

BOX 2, BAG FOR PAGE 7

ONE WAY PULLEY ASSEMBLY

Already Assembled With Loctite

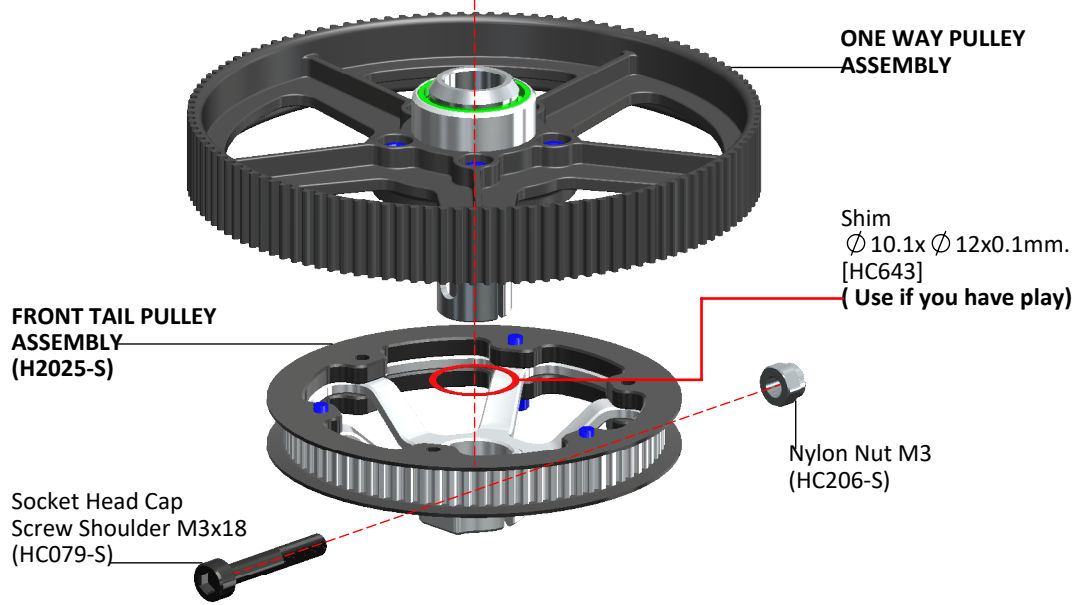
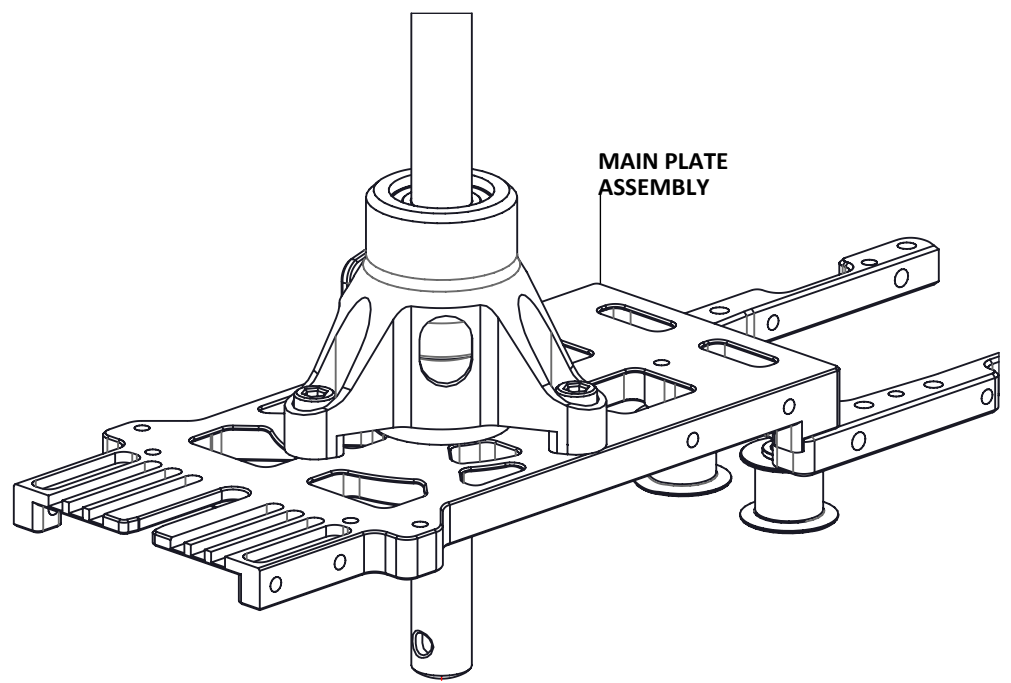
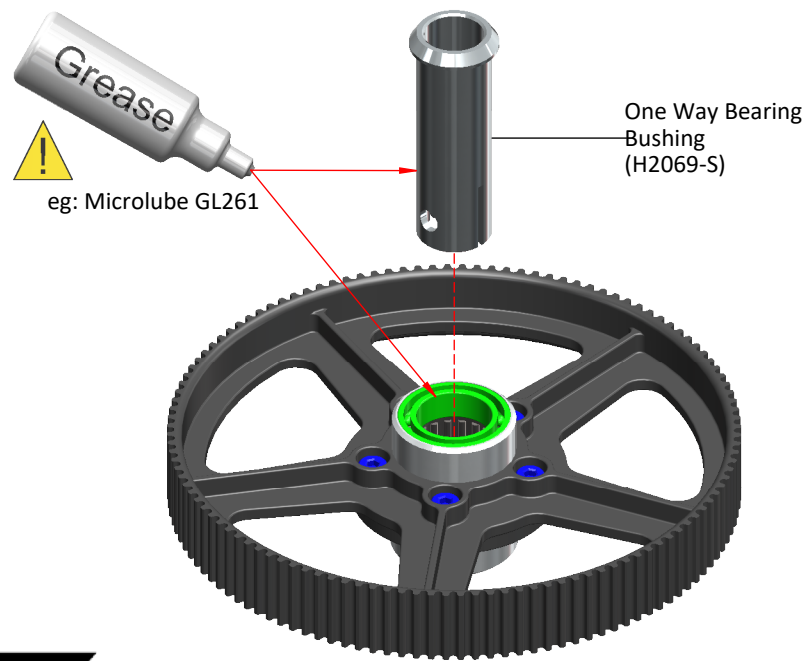
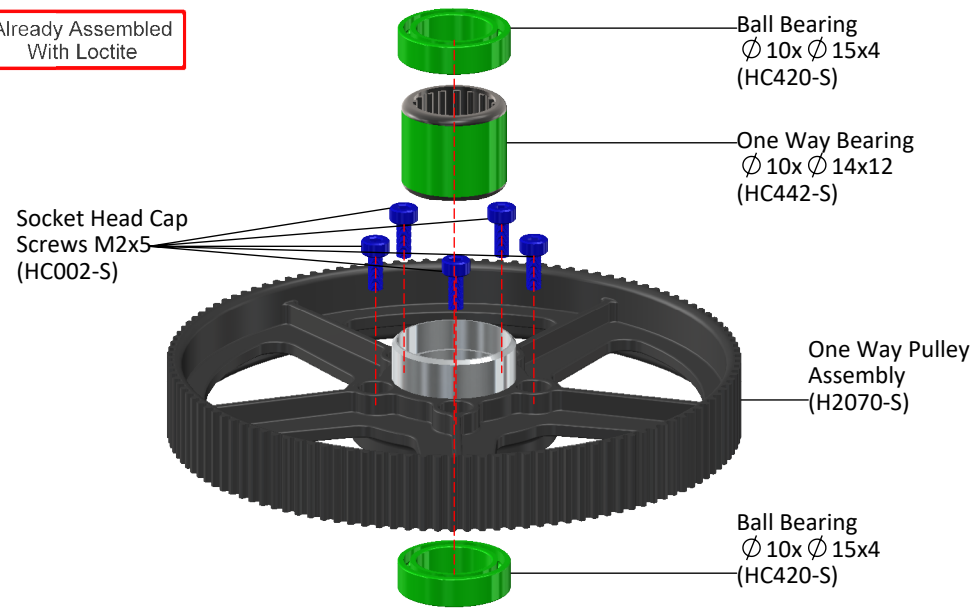

SERVO ASSEMBLY

The linkage ball must be positioned 13-15mm out on the servo arm.
 The recommended servo arm to use is: SAB p/n [HA052].
 Ensure the alignment of the servo arms before installation of the servos in the model.
 Proceed with installation following the instructions below.

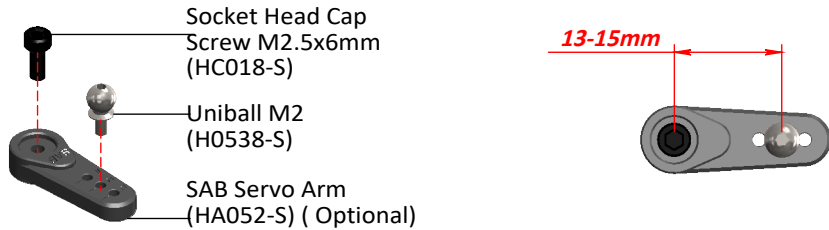

Note: Do not over tighten the uniball, be careful not to strip the plastic

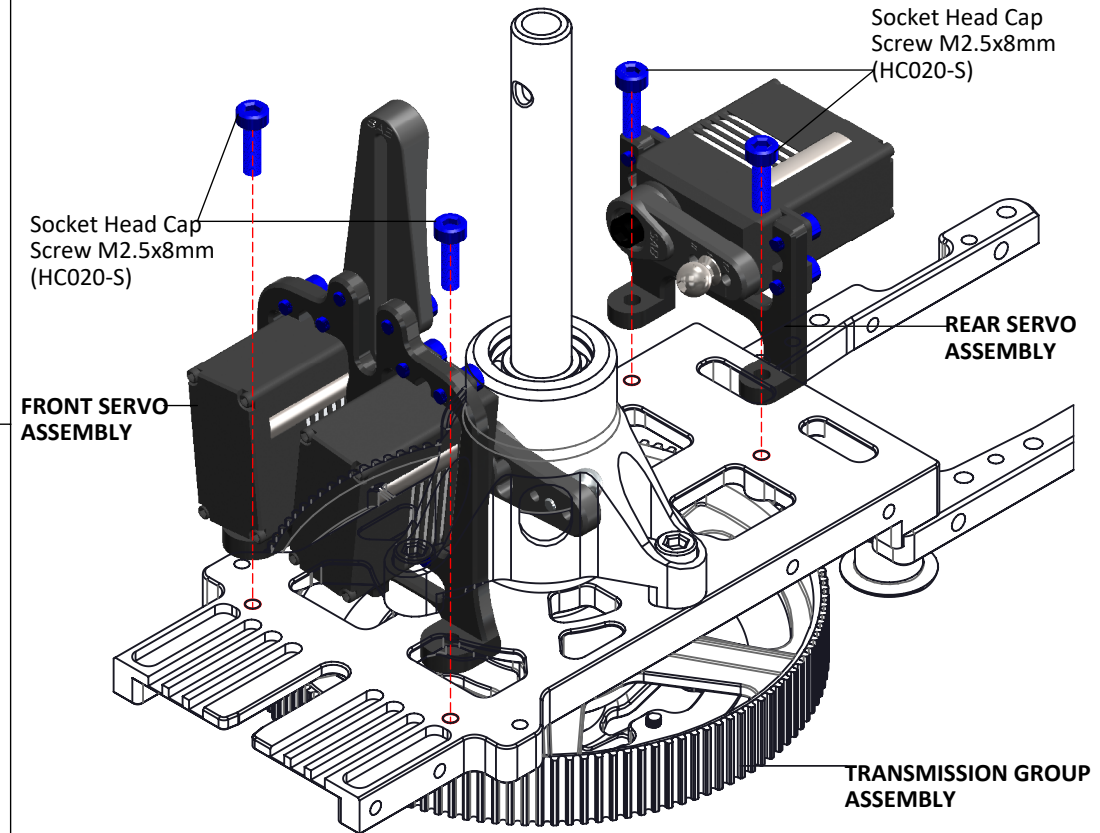
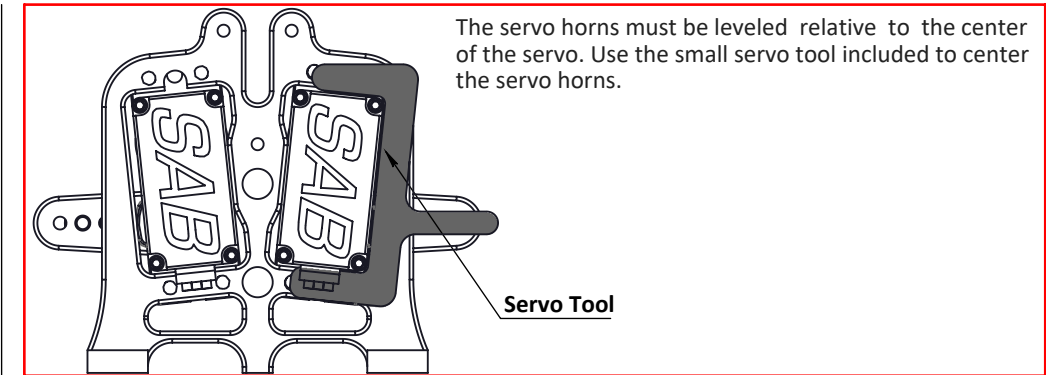
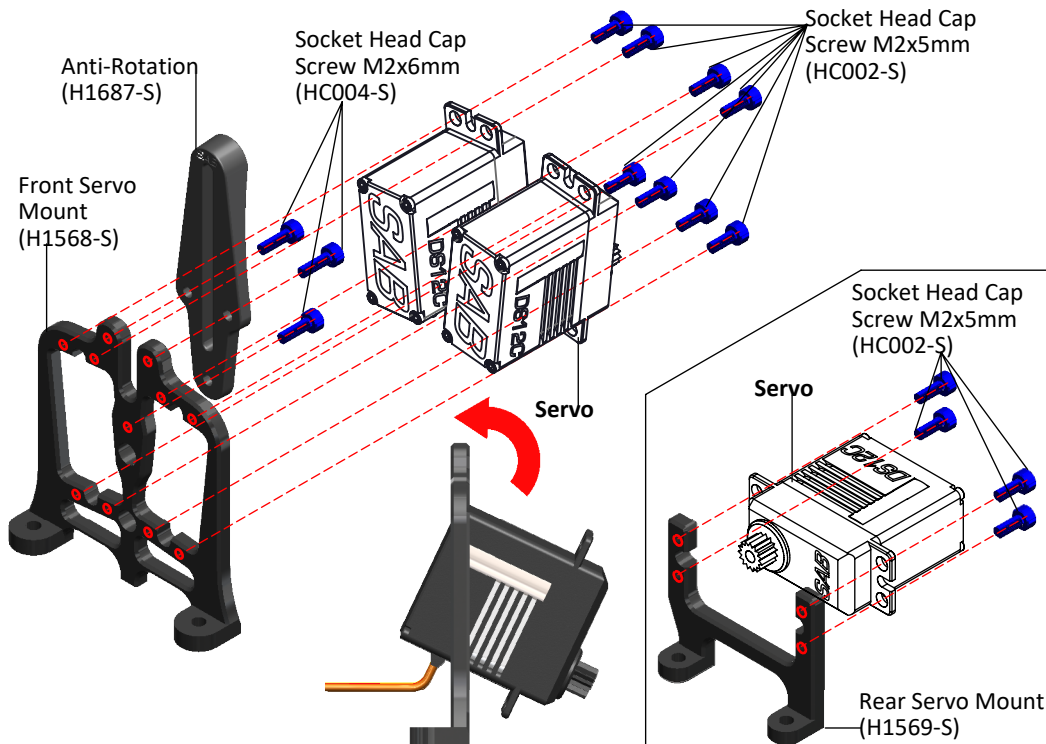

BOX 2, BAG FOR PAGE 9

CARBON FRAME

 The manufacturing process of the carbon parts often leaves micro-burrs and sharp edges. We recommend de-burring the edges to minimize the risks of electrical wire cuts, etc. It is very important to do this along the red lines.

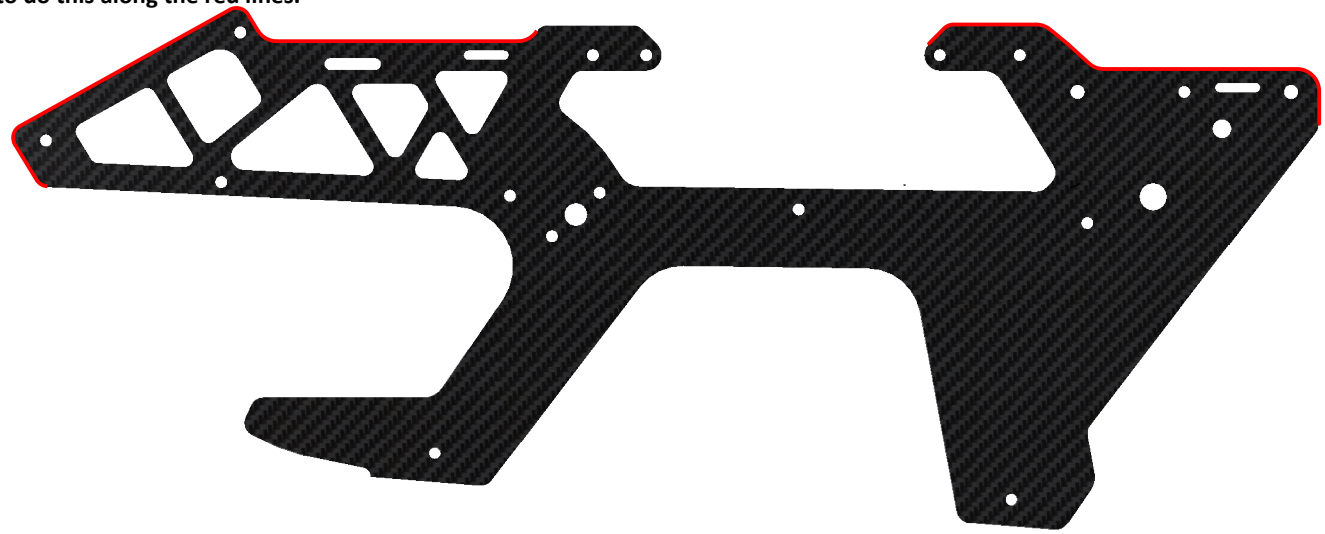

LEFT MAIN FRAME ASSEMBLY

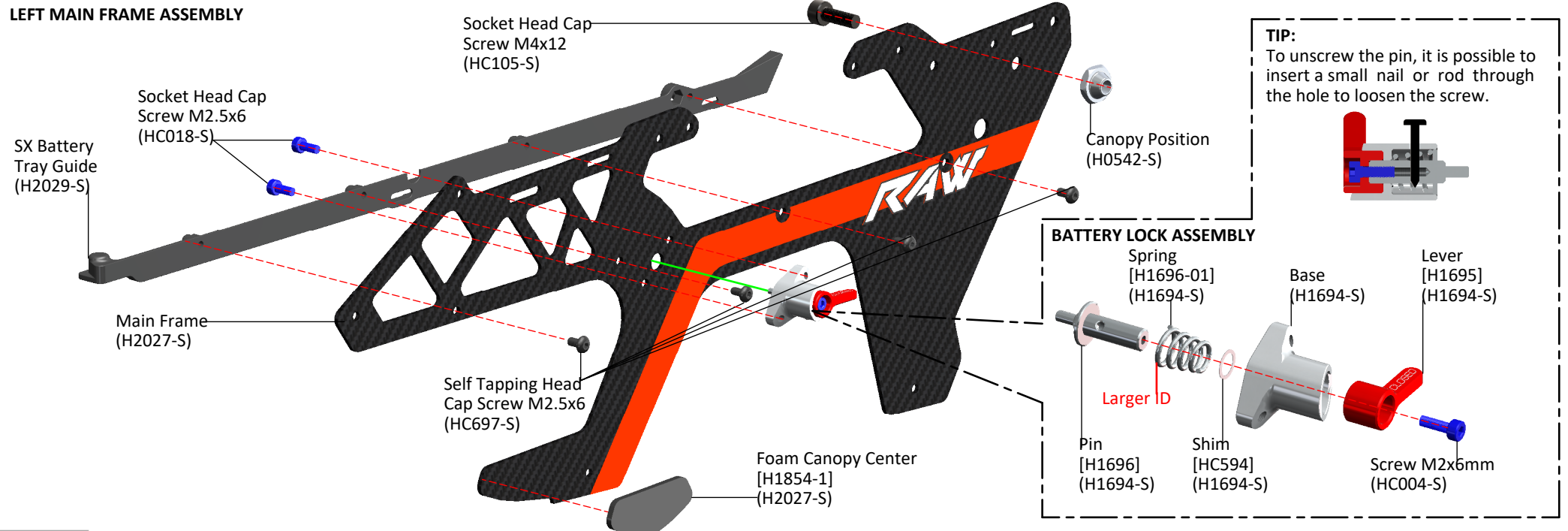

TIP:
To unscrew the pin, it is possible to insert a small nail or rod through the hole to loosen the screw.

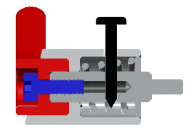

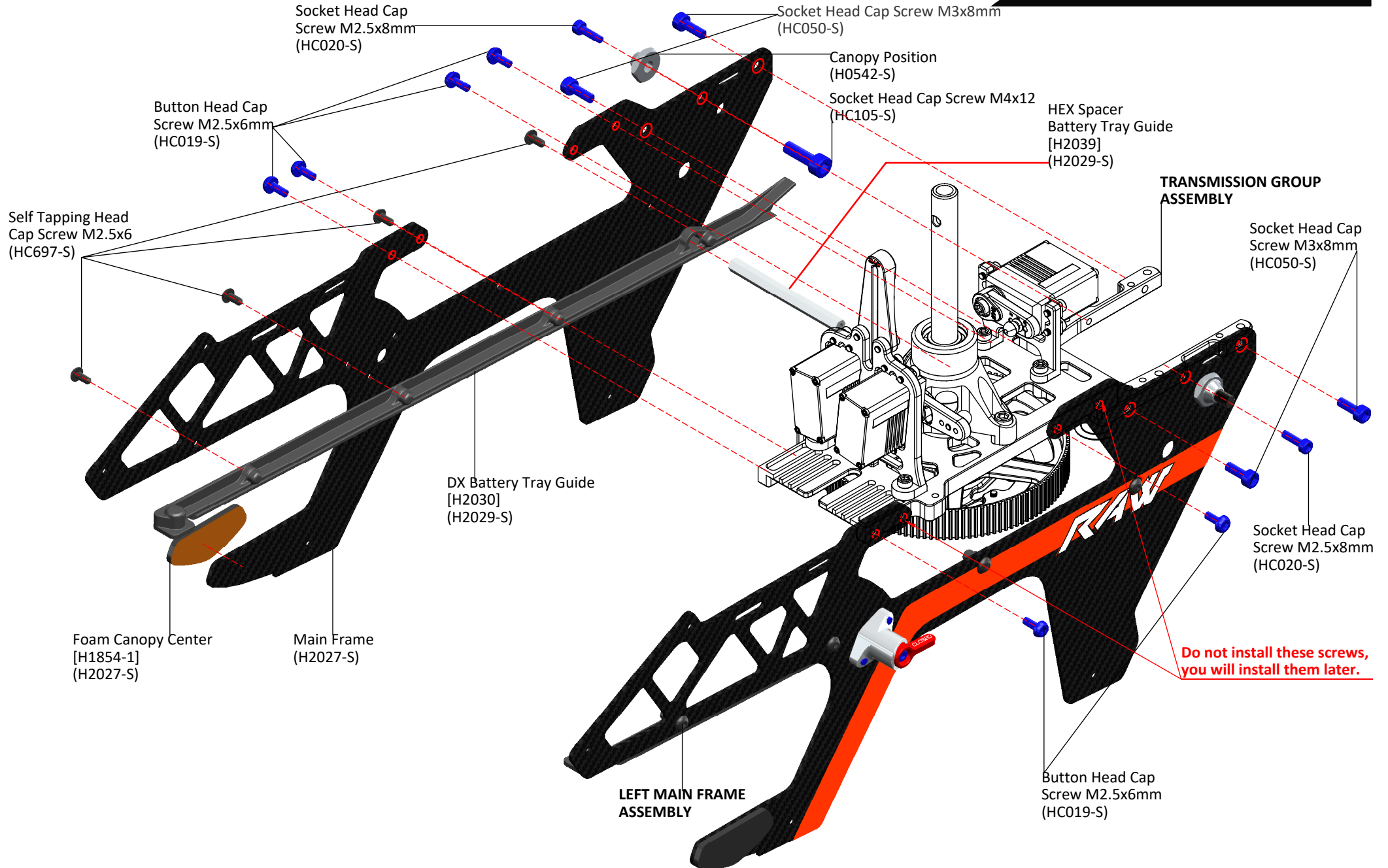

BOX 2, BAG FOR PAGE 11

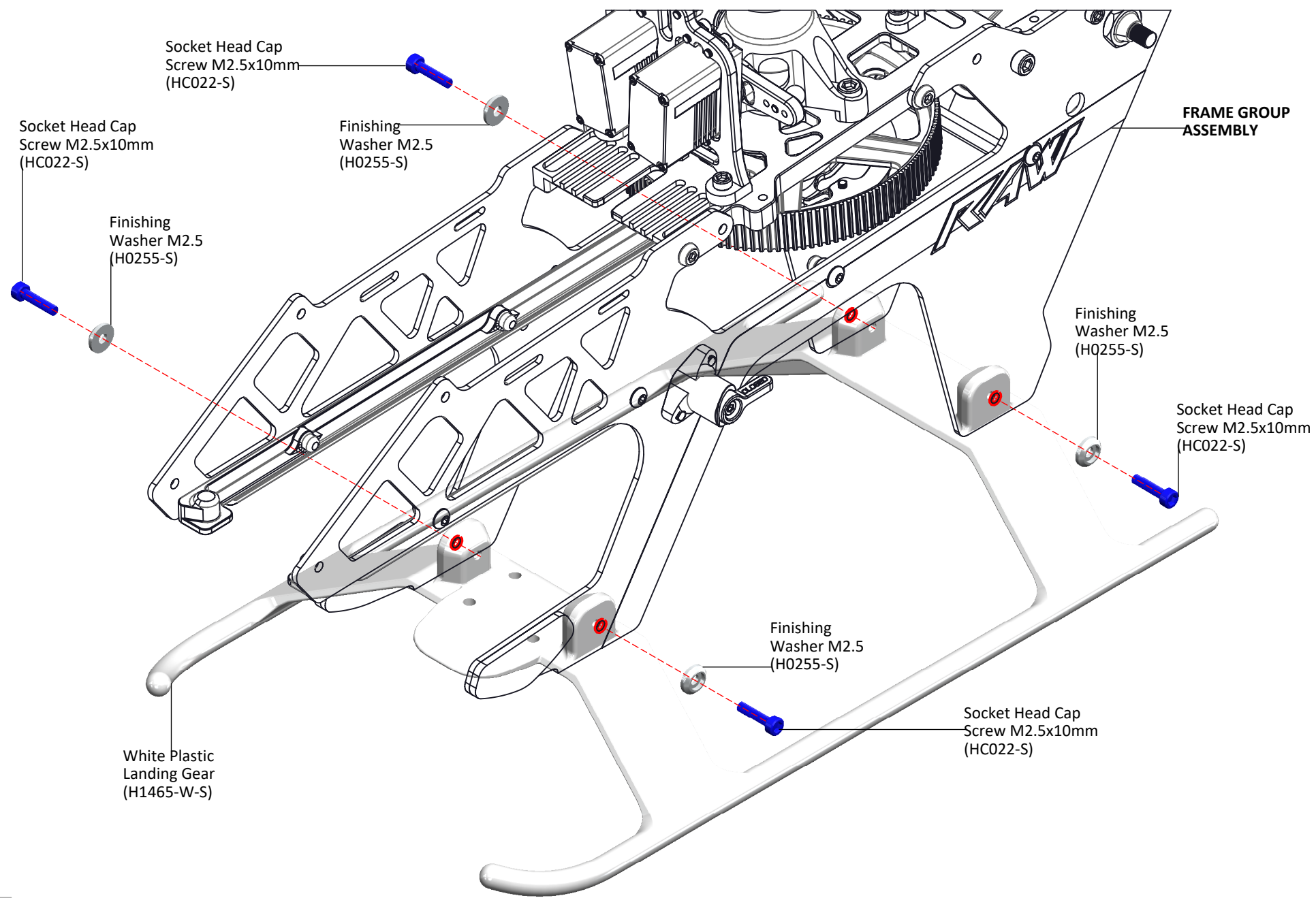

PLEASE USE GREEN THREAD LOCK to secure the bearings to the radius arms. Failure to secure the bearing will result in excessive slop/play.

RADIUS ARM ASSEMBLY ... x2

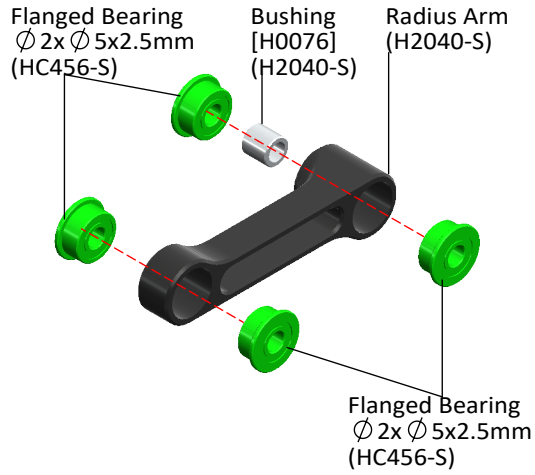

RADIUS PLASTIC ARM ASSEMBLY ... x2

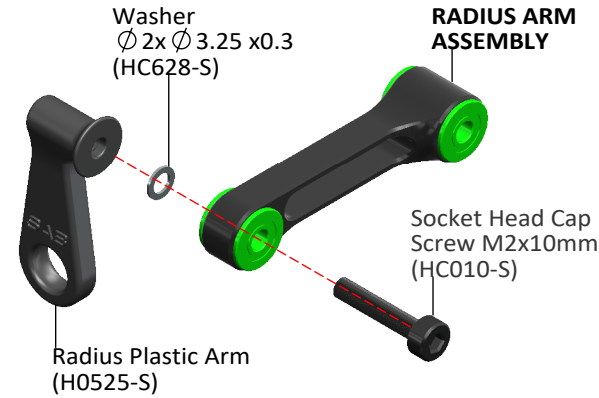

NOTE: Tighten with care, the arm must move freely.

LINKAGE ROD ASSEMBLYx2

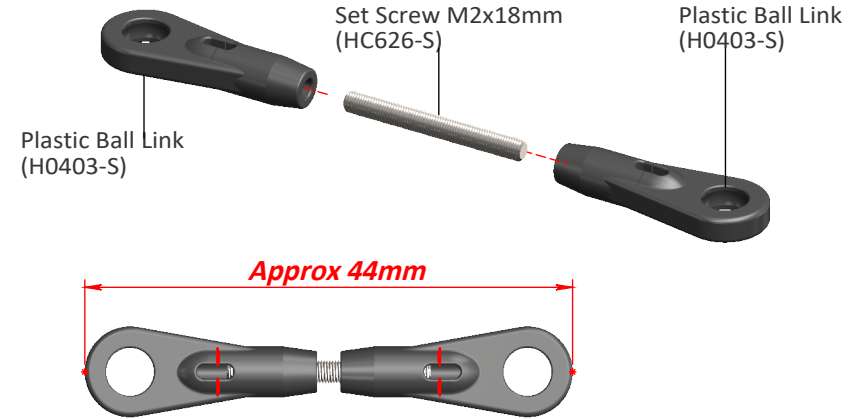

(Initial length for the rods from the swashplate to the Blade Grip.)

CENTER HUB ASSEMBLY

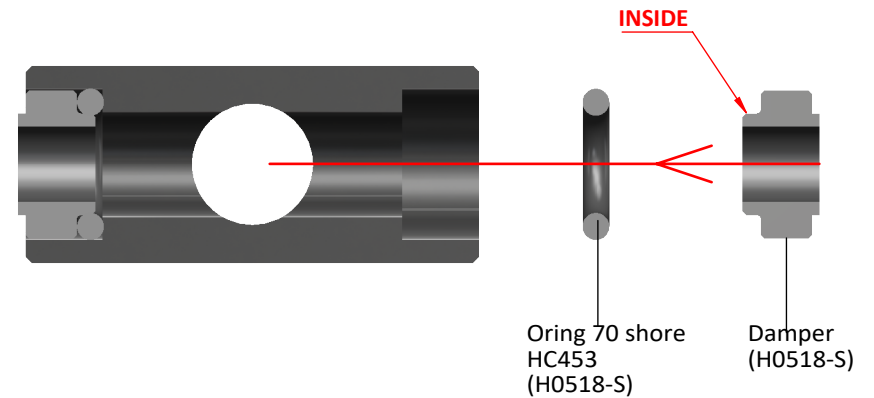
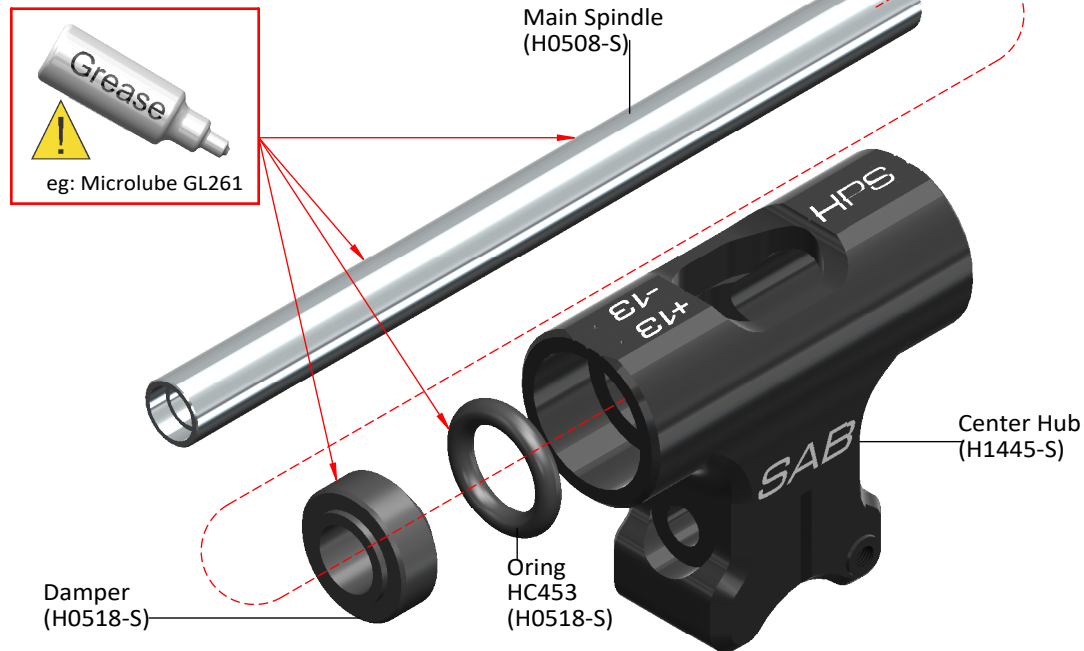

BOX 2, BAG FOR PAGE 13

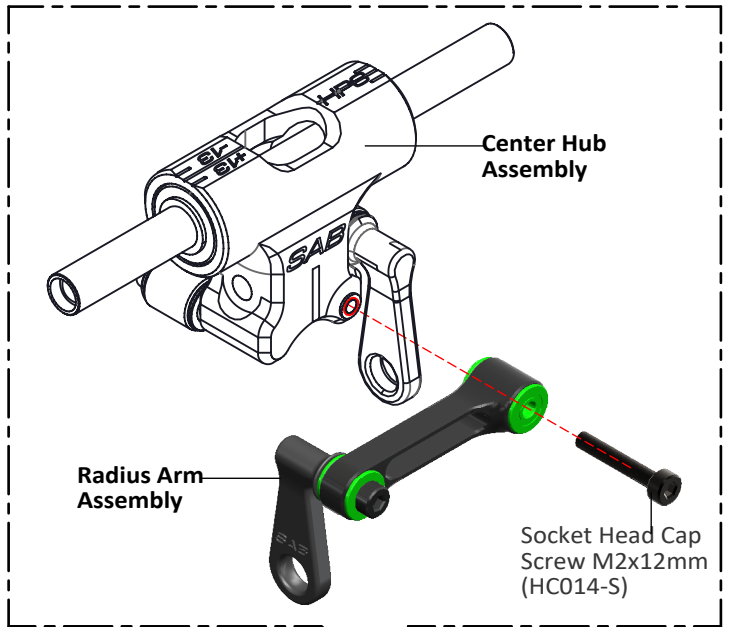

NOTE: We recommend assembling without shims. After approximately 20/30 flights, please manually check the head dampening, you can add one 0.1mm shim each side (HC450) if the dampening feels loose.

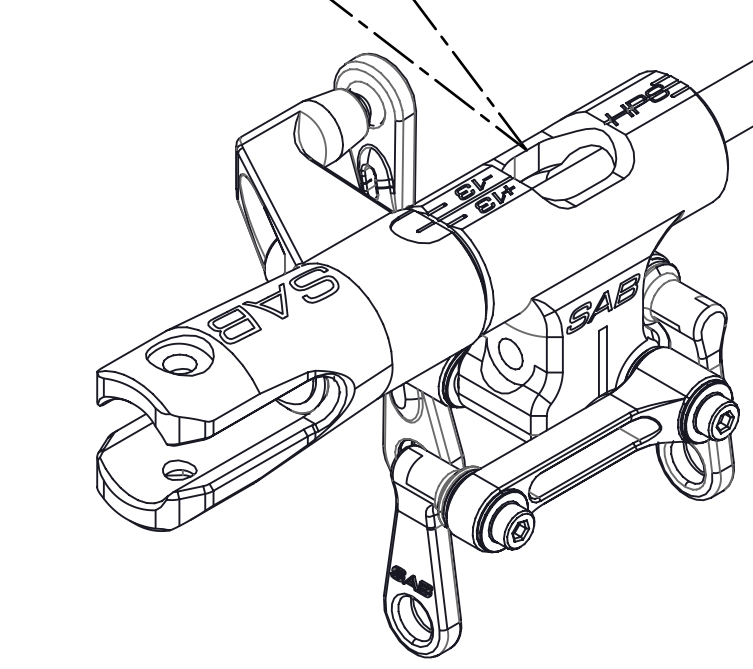

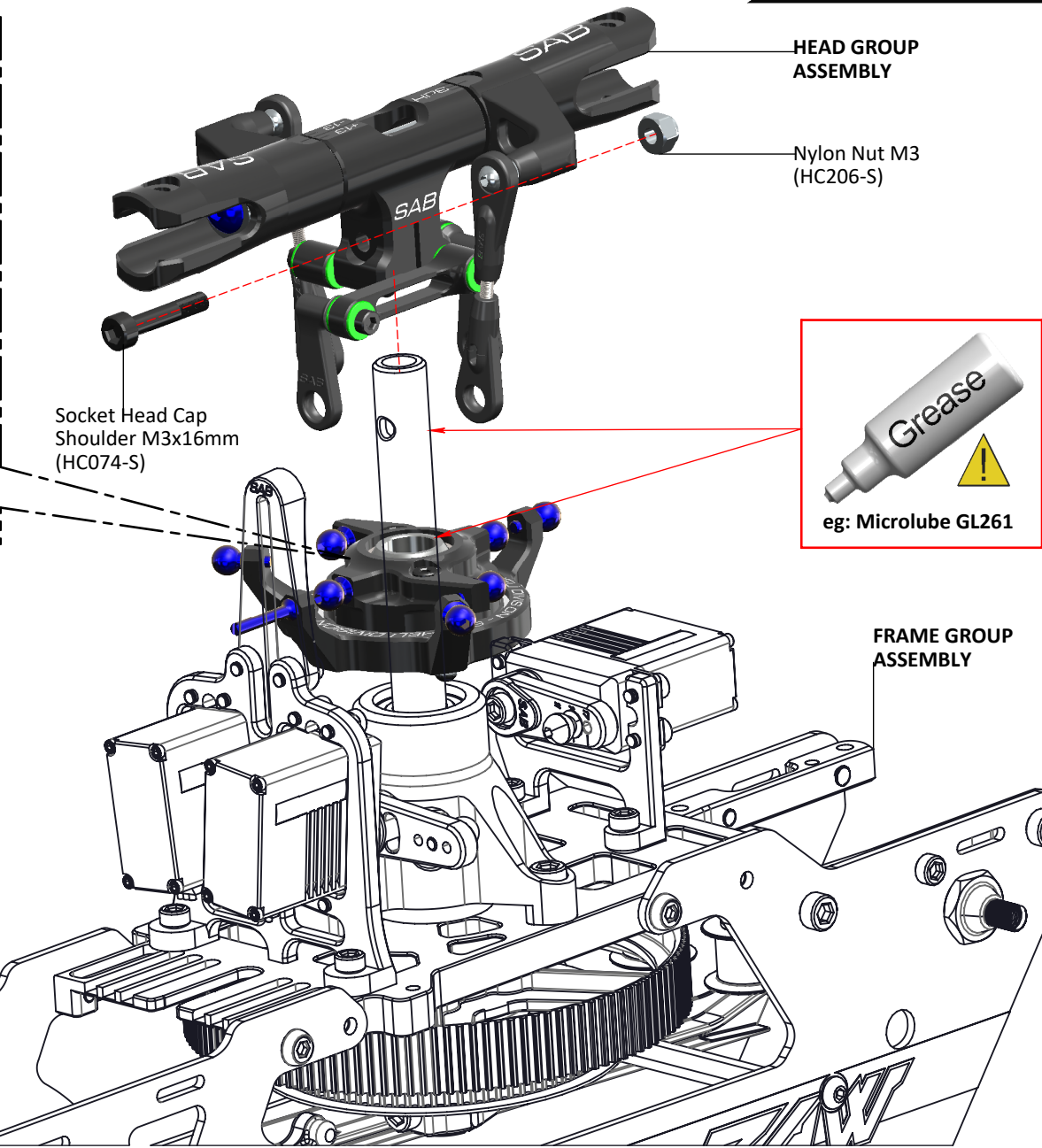
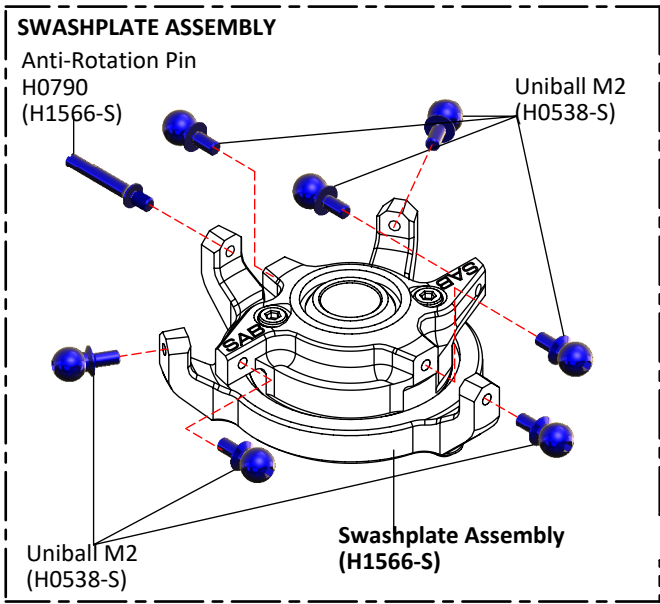

BOX 2, BAG FOR PAGE 15

LINKAGE ROD B ASSEMBLY ... X3

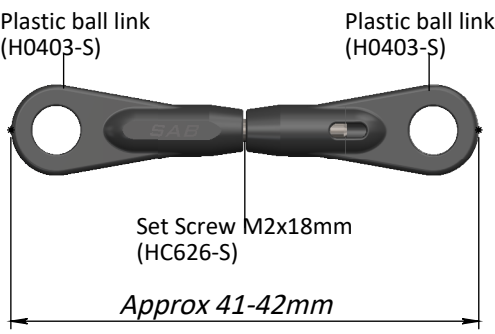

Plastic ball link (H0403-S) Plastic ball link (H0403-S)

Set Screw M2x18mm (HC626-S)

Approx 41-42mm

Initial length for the rods from the servos to the swash plate.

SUGGESTED:
You can use the Swashplate Leveler H1686-S (Not included KIT)

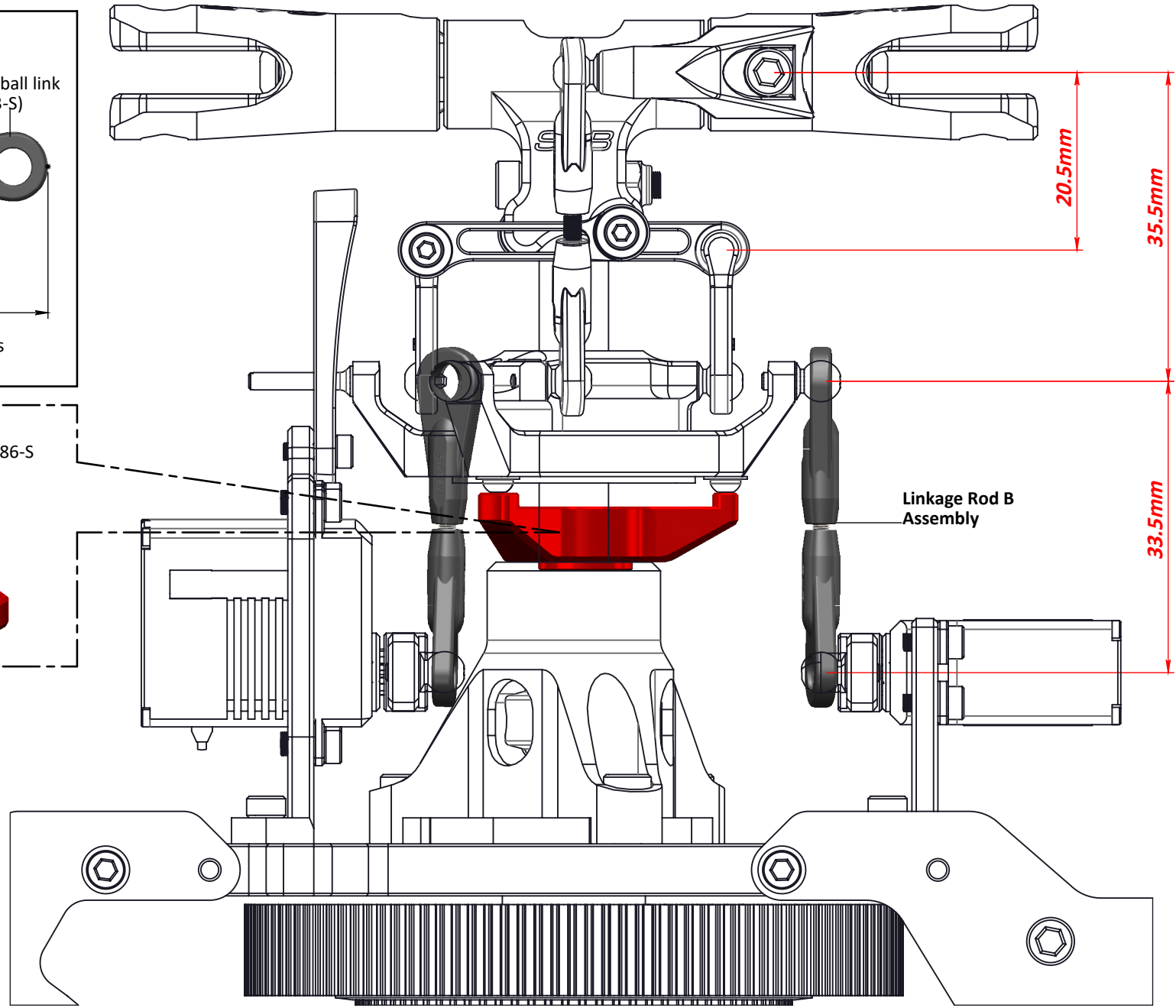
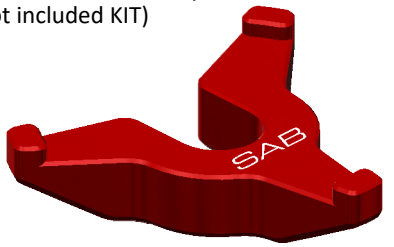

It is important to choose the right reduction ratio to maximize efficiency based on your required flight performance.

It is recommended to use wiring and connectors appropriate for the currents generated in a helicopter of this class.

If you are using a head speed calculator which requires a main gear and pinion tooth count, use 120 teeth for the main gear

BELOW IS A LIST OF AVAILABLE REDUCTION RATIOS:

- | | | | |
|---------------------------------|----------------|---------------------------------|----------------|
| H0501-19-S - 19T Pinion = ratio | 6.3 : 1 | H0501-22-S - 22T Pinion = ratio | 5.5 : 1 |
| H0501-20-S - 20T Pinion = ratio | 6.0 : 1 | H0501-23-S - 23T Pinion = ratio | 5.2 : 1 |
| H0501-21-S - 21T Pinion = ratio | 5.7 : 1 | H0501-24-S - 24T Pinion = ratio | 5.0 : 1 |

GOBLIN RAW 420 CONFIGURATIONS (BLADES 420mm)

| MOTOR | ESC | Motor Pulley | RPM Max | Pitch |
|-----------------------|--------------------------|------------------|--------------------|--------|
| Scorpion HK5 3220-955 | Scorpion Tribunus 06-80A | 20T - 21T | 3300 - 3400 | ± 12.5 |
| XNOVA 3220-945 | | 21T - 22T | 3300 - 3400 | |
| TENGU 3220HS / 960KV | | 20T - 21T | 3300 - 3400 | |
| MINIPYRO 400-10 | Platinum 80A V4 | 19T - 20T | 3300 - 3400 | |
| XNOVA 3215-935 | KOLIBRI 90LV-I | 20T - 21T | 3200 - 3300 | |
| XNOVA 2820-890 | | 21T - 22T | 3200 - 3300 | |
| TENGU 3220HS / 900KV | | YGE 95LVT | 21T - 22T | |



NOTE: For safety reason we recommend not exceeding 3400 RPM.

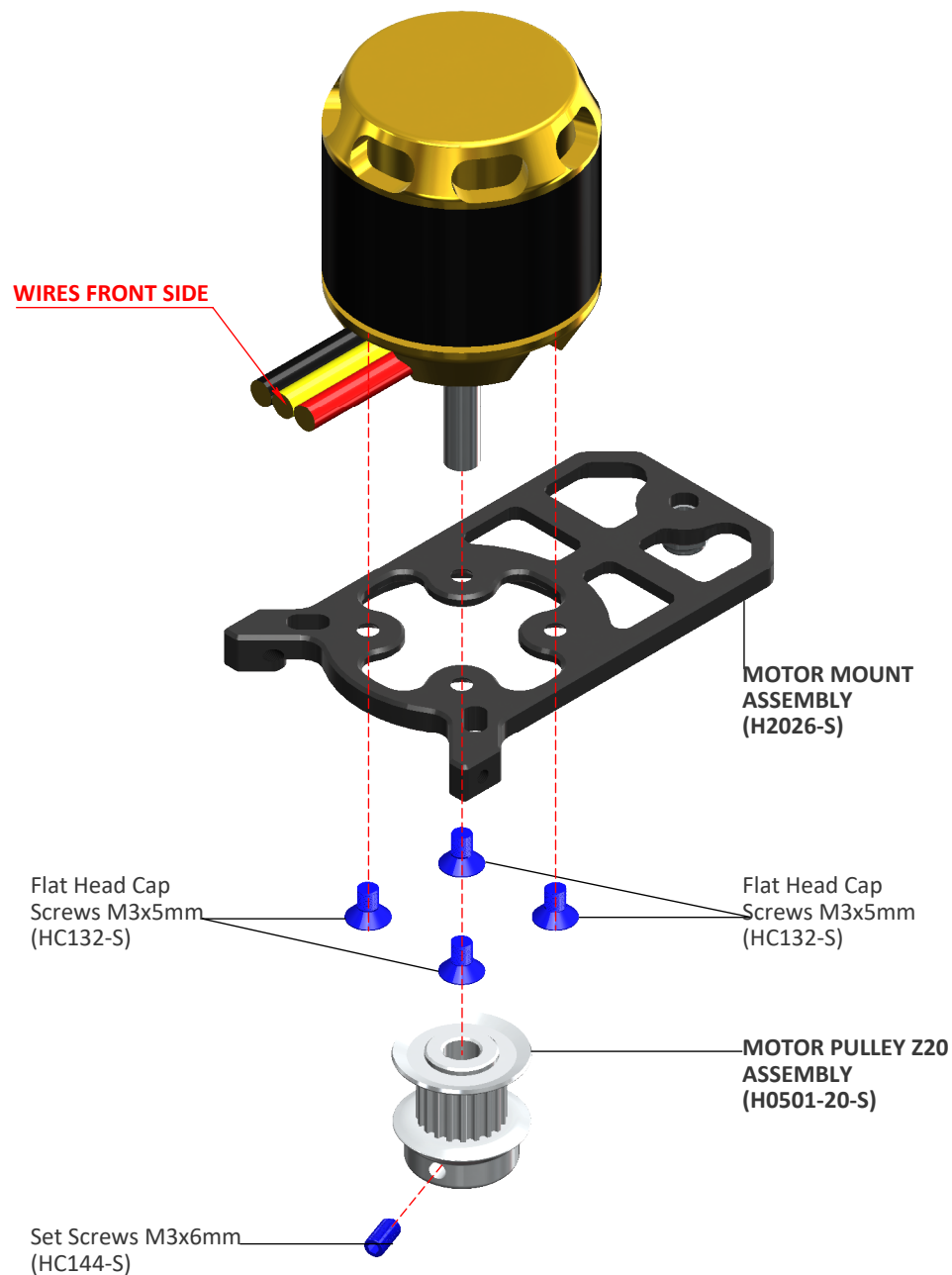

BOX 2, BAG FOR PAGE 17

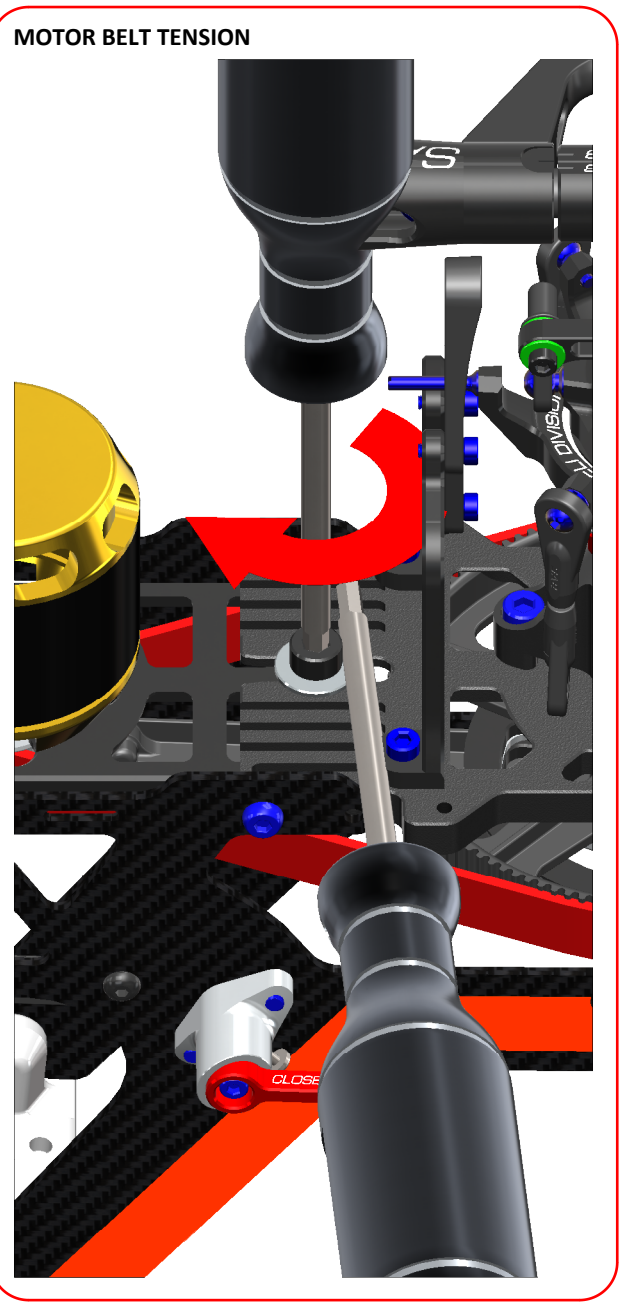
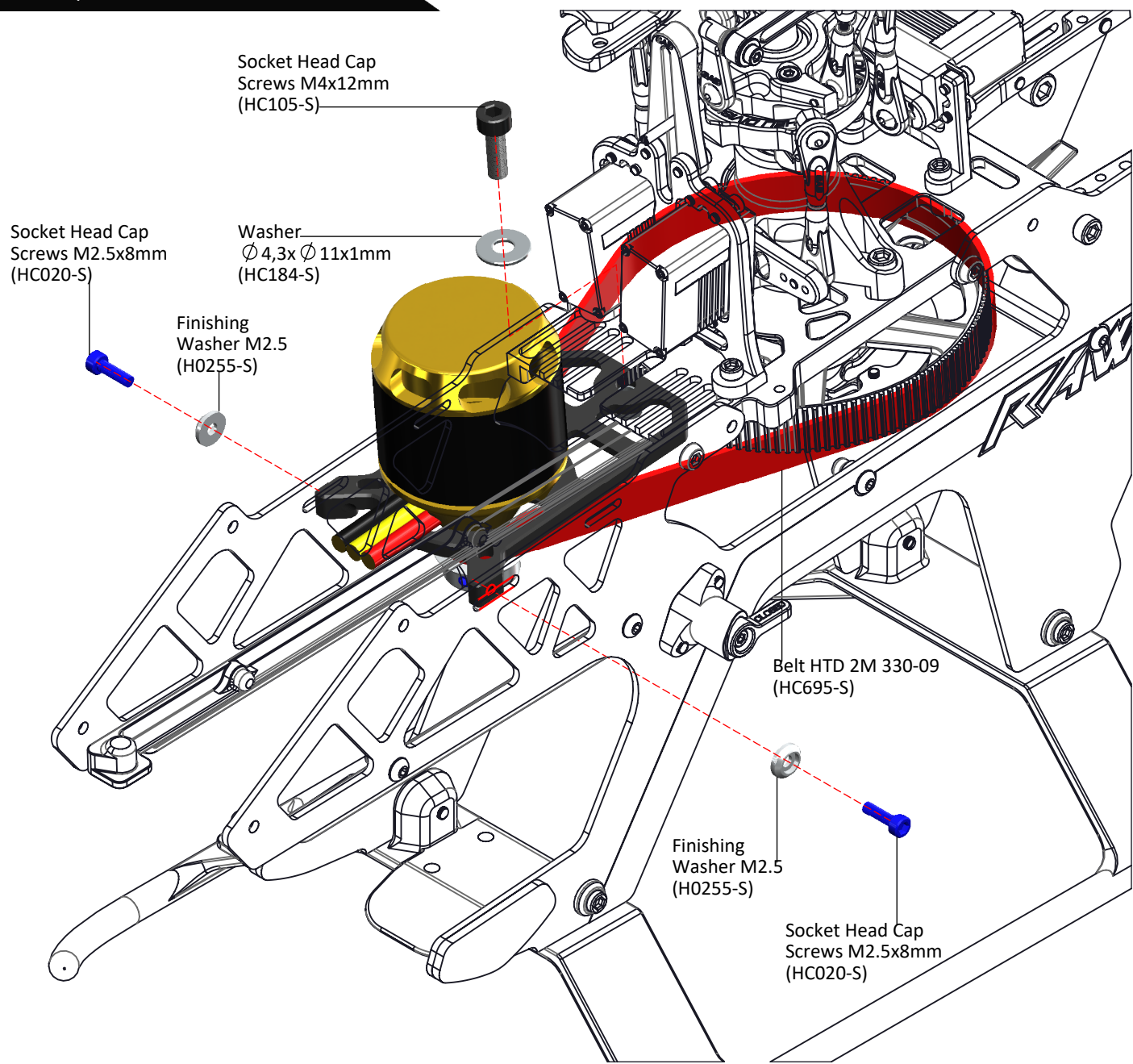

NOTE:
It is normal for the tail to feel a bit tight after initial assembly as the tail spindle preload is usually high when the helicopter is brand new. The preload will loosen up after 2-5 flights allowing the system to become smooth.

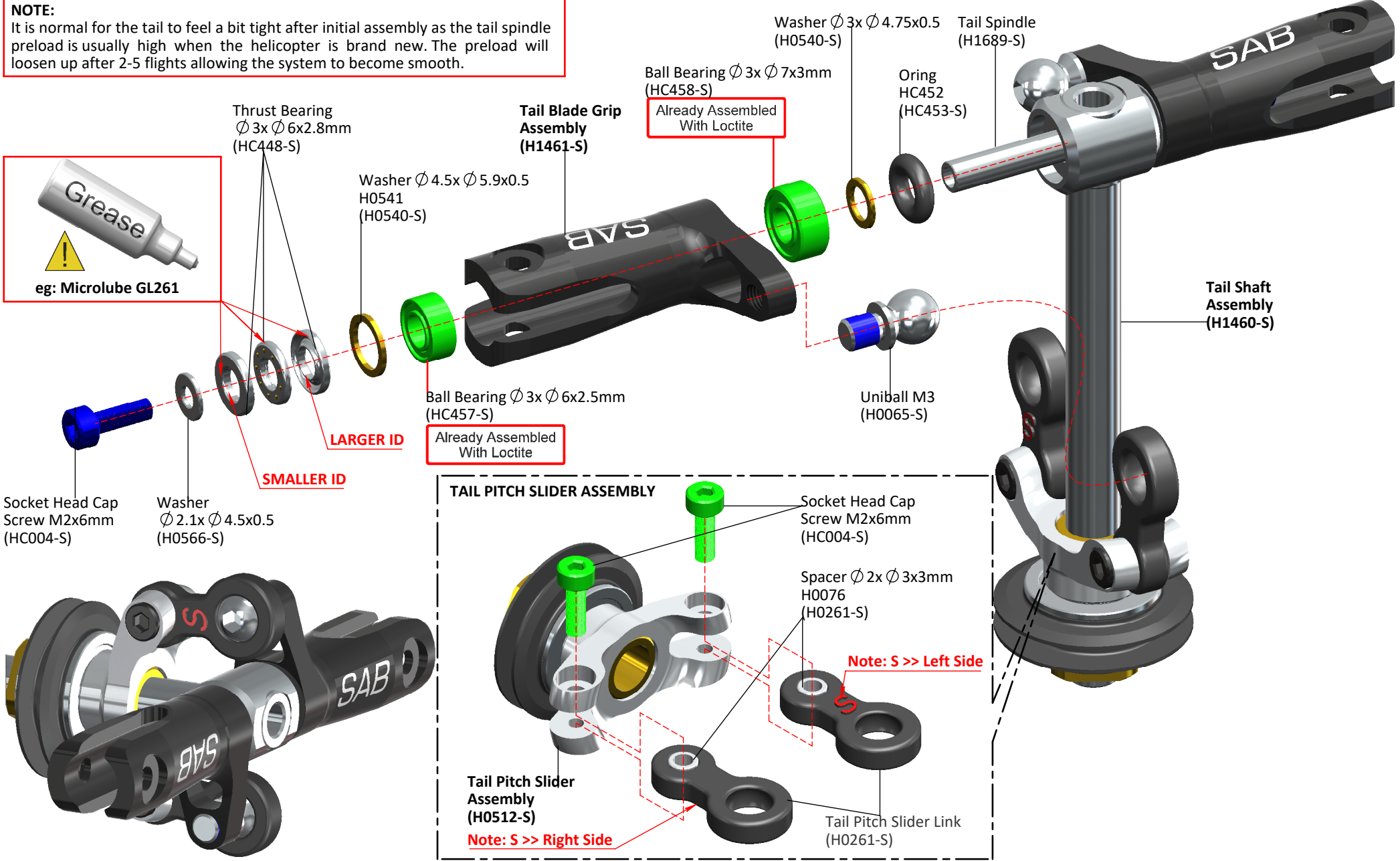

BOX 2, BAG FOR PAGE 19

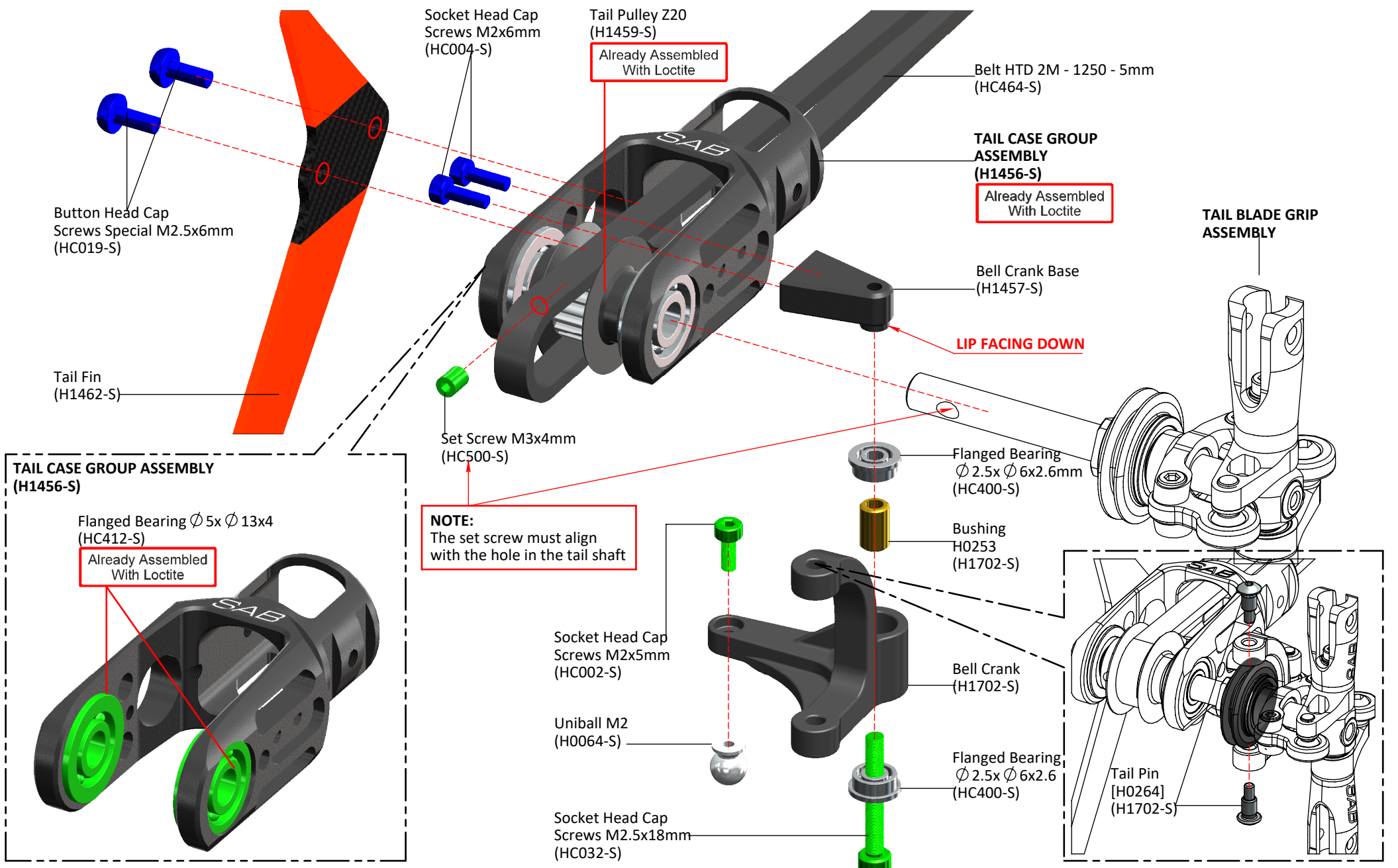

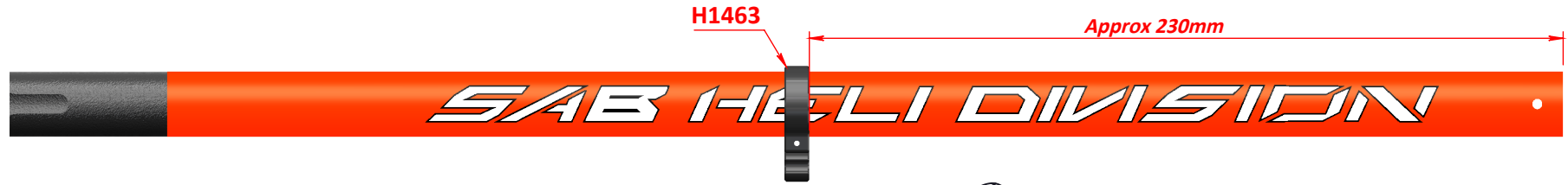

NOTE:
Please use a Tie Rod to insert the belt into the tube.

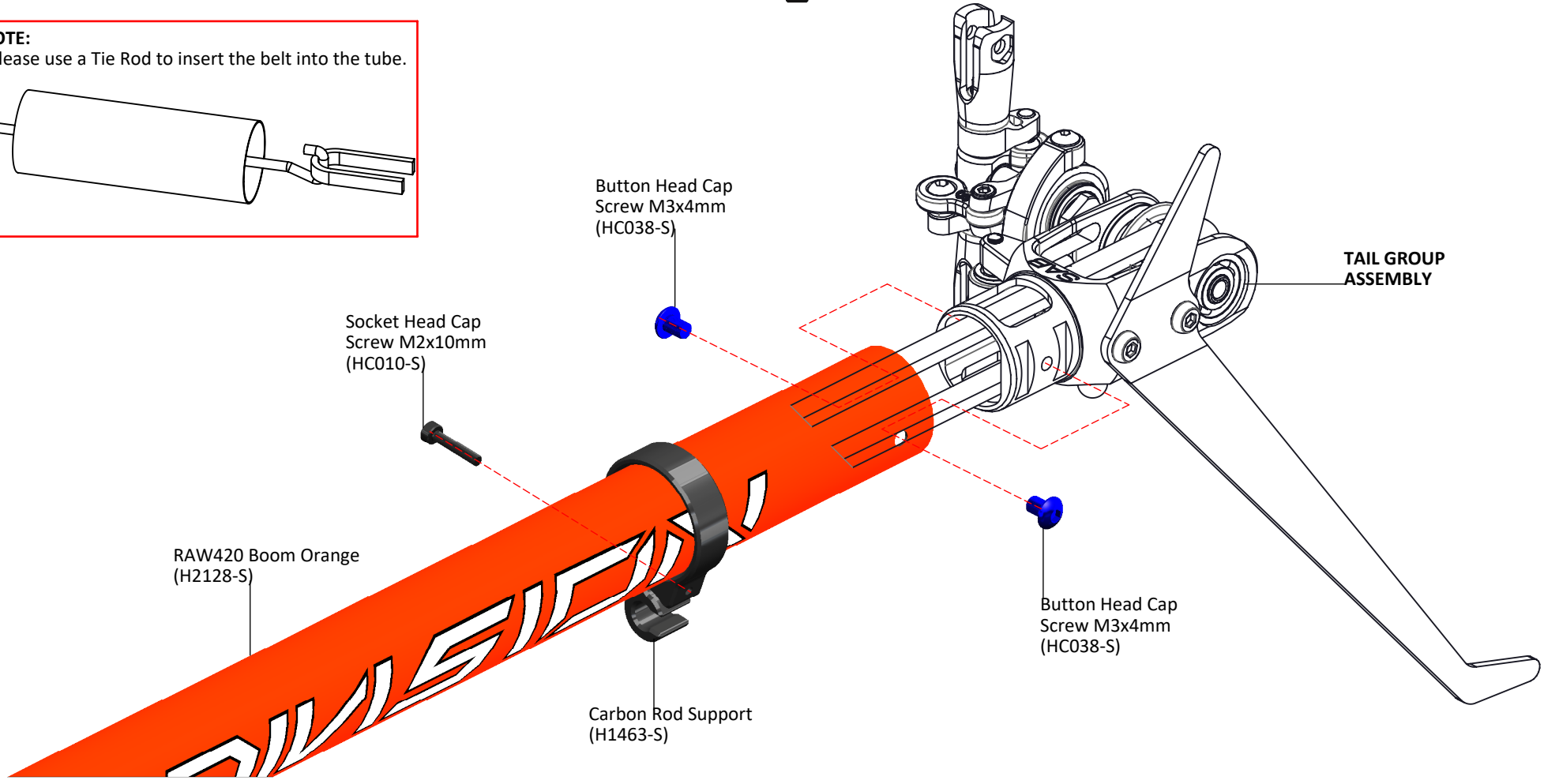

BOX 2, BAG FOR PAGE 21

BOOM CLAMP ASSEMBLY

NOTE: Do not tighten the M2.5x12 at this moment.

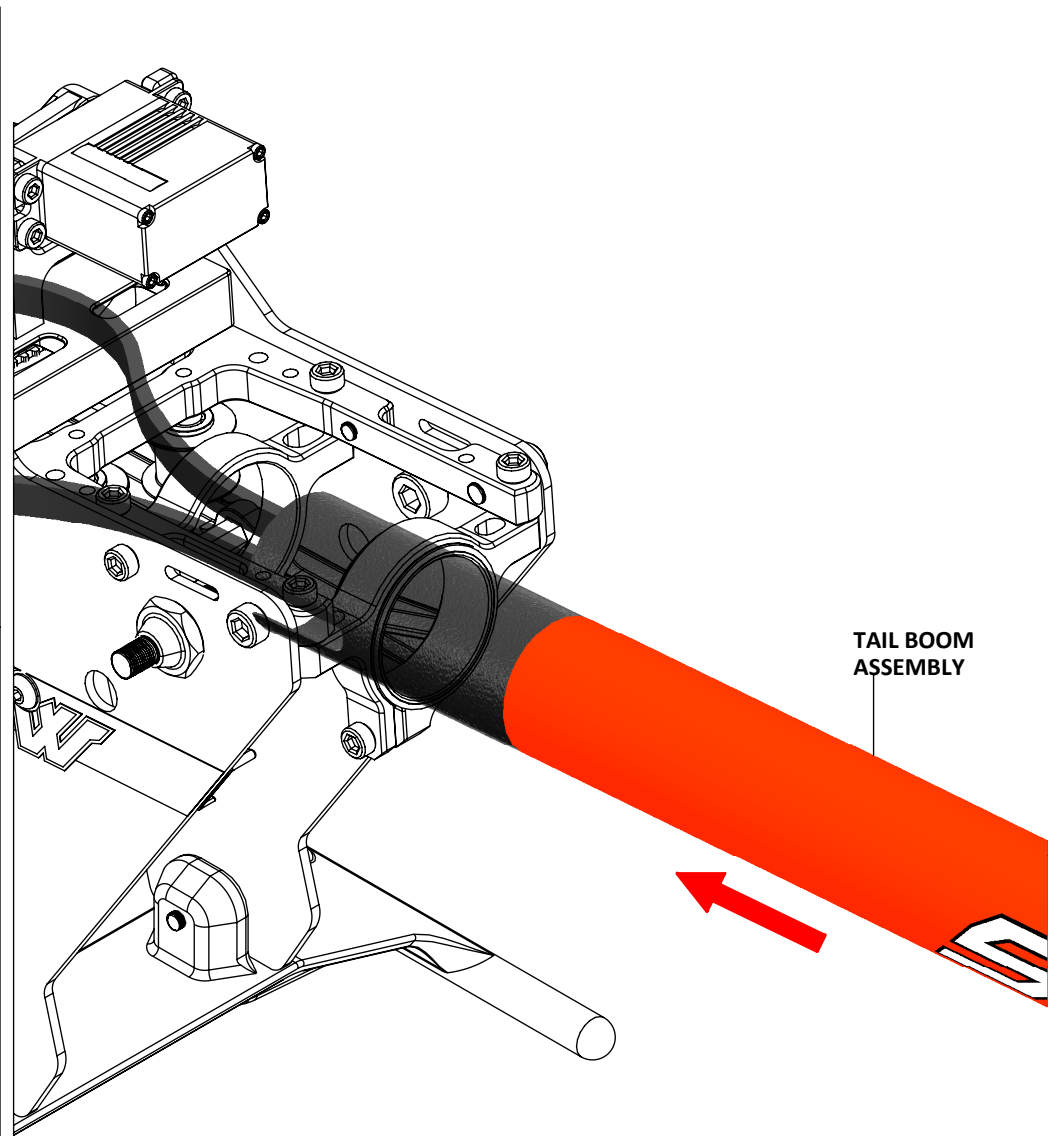
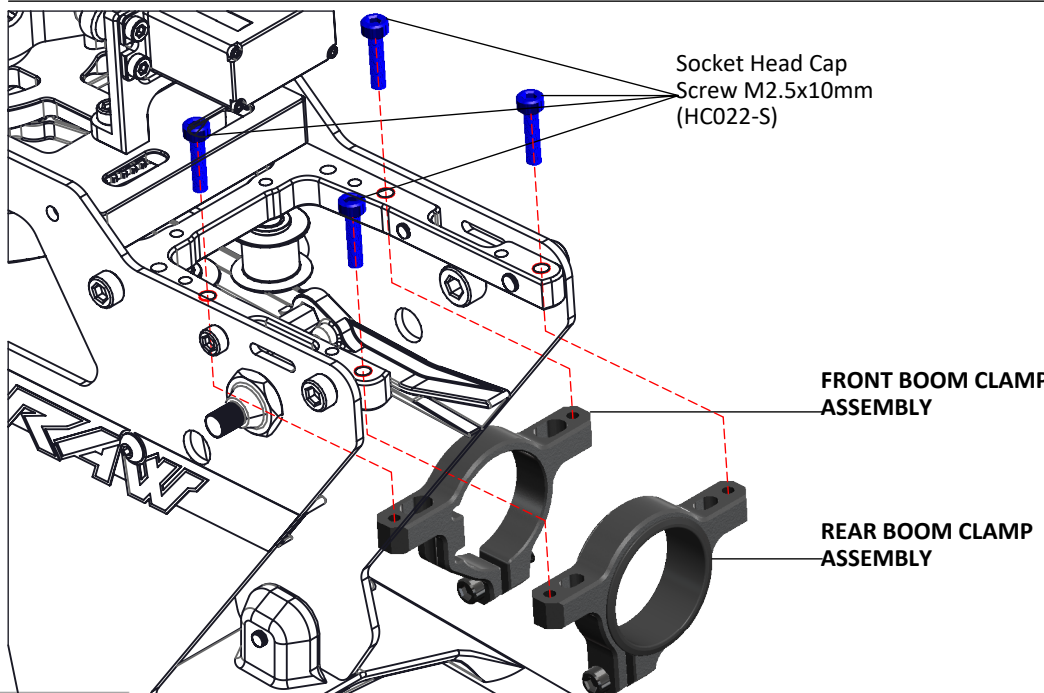
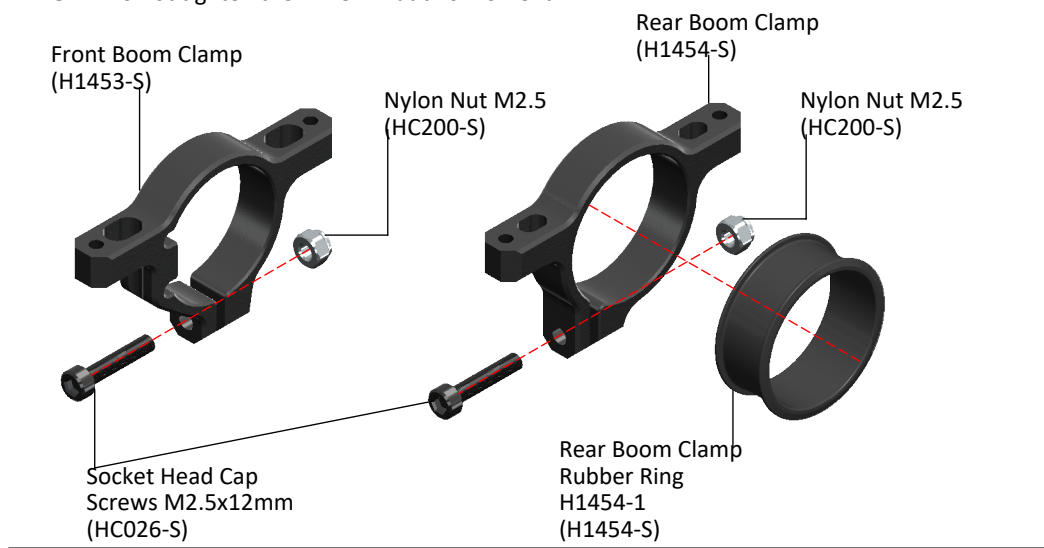

TAIL BOOM ASSEMBLY

- *Use the M3 screws to open the tail belt tensioner (See page 19).
- *Install the belt onto the tail front pulley, checking the direction of rotation.
- Rotate the belt 90 ° counterclockwise (Fig. 1).
- *Rotate the main rotor several times by hand.
- *Tension the tail belt by using the tool kit to slide the boom backwards.
- *Then slowly tighten the two red screws. (Fig. 2).

HOW TO USE THE TAIL BELT TENSION TOOL:

1. Insert fully the plastic rod (H1703-03) by unscrewing **the orange screw M2.5x12** and pushing the rod.
2. Install the tool on the boom, it needs to touch the H1454 clamp.
3. Tighten **the pink M2.5x10 screw** to lock the tool onto the boom.
4. Make sure the bolts for the tail boom clamp are not fully tightened yet.
Turn **the orange M2.5x12 screw** to tension the tail belt.
This will push the boom back, thus tightening the tail belt.
5. Once the correct tension is achieved, tighten the two boom clamps with **the two M2.5 screws**.
6. Remove the tool before flight.

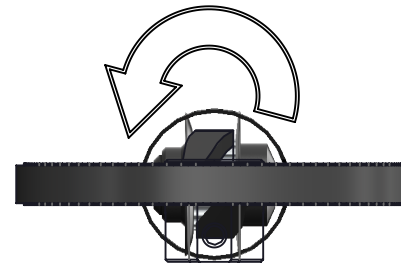
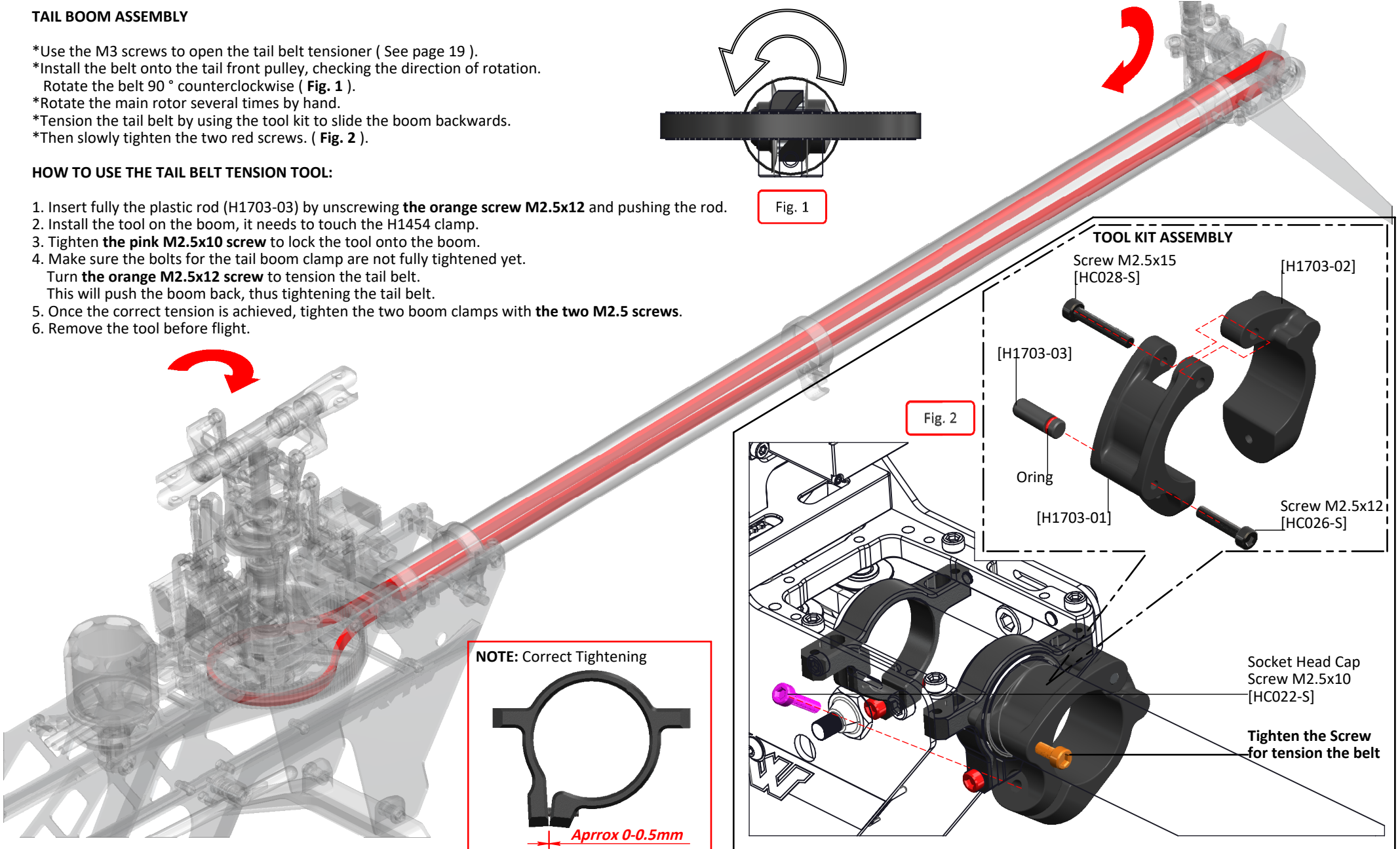

Fig. 1



TOOL KIT ASSEMBLY

- Screw M2.5x15 [HC028-S]
- [H1703-02]
- [H1703-03]
- Oring
- [H1703-01]
- Screw M2.5x12 [HC026-S]

Fig. 2

NOTE: Correct Tightening

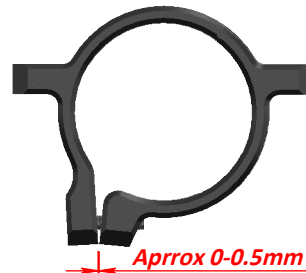

Socket Head Cap Screw M2.5x10 [HC022-S]

Tighten the Screw for tension the belt

BOX 2, BAG FOR PAGE 23

TAIL SERVO ASSEMBLY

Socket Head Cap Screw M3x6mm (HC044-S)

Uniball M2 (H0064-S)

Servo Arm (HA052-S)

Socket Head Cap Screw M2x6mm (HC004-S)

13-15mm

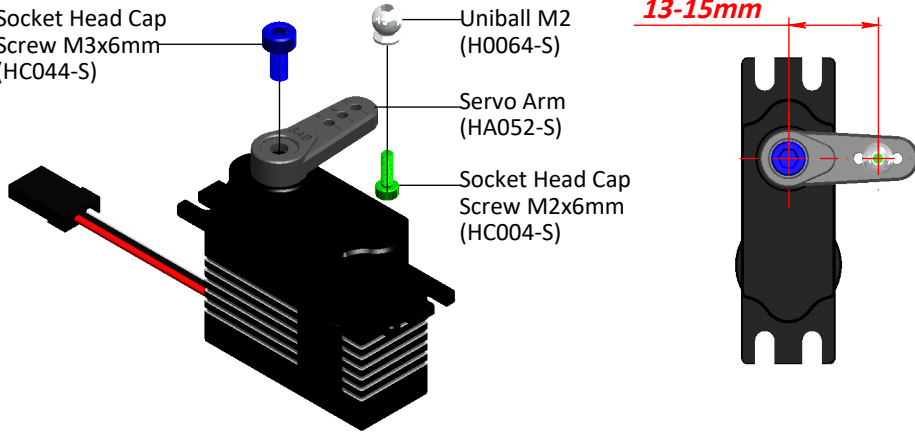

Socket Head Cap Screw M2.5x8mm (HC020-S)

Servo Spacer (H0572-S)

Servo Spacer (H0572-S)

Tail Servo Mount [H2034-01] (H2034-S)

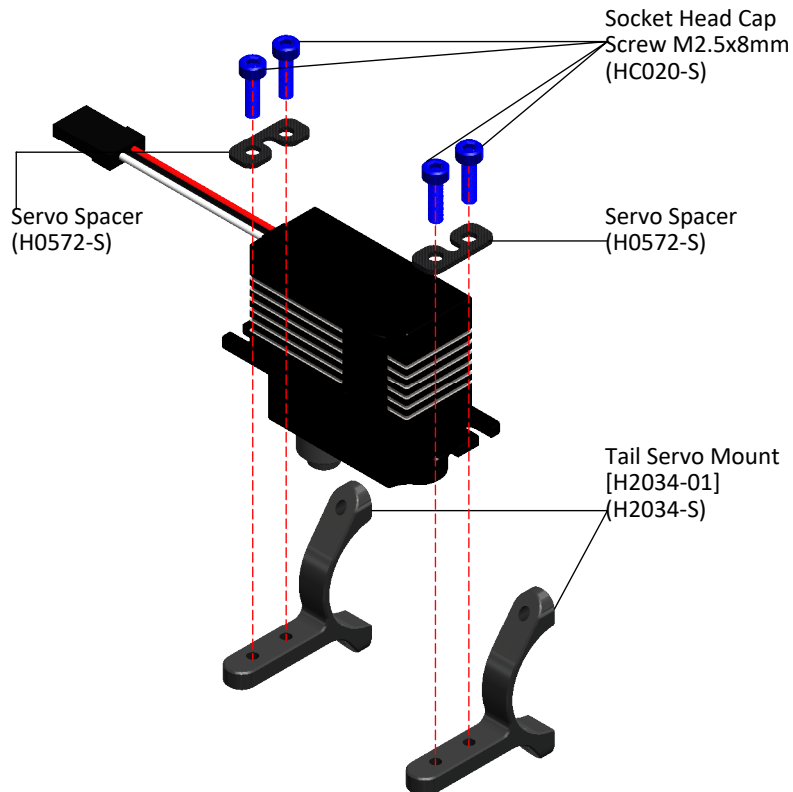

Note: Tighten carefully. Overnighting can damage the Boom.

Antenna Support (H2035-S)

Socket Head Cap Screw M2.5x8mm (HC020-S)

Tail Servo Mount [H2034-02] (H2034-S)

TAIL SERVO ASSEMBLY

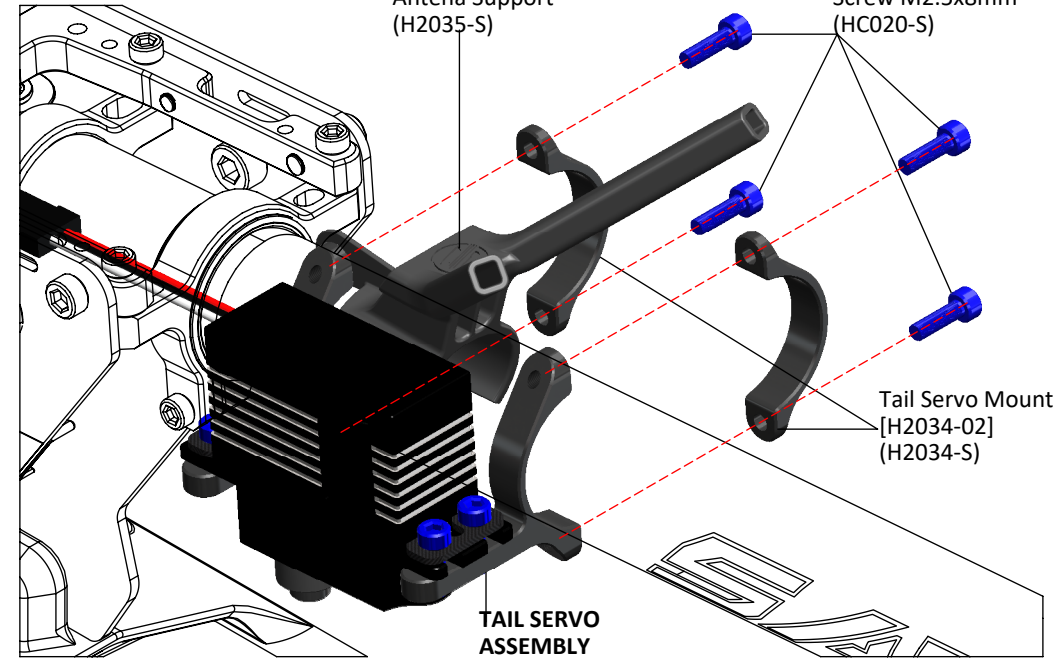

Approx 15mm

PARALLEL

1mm

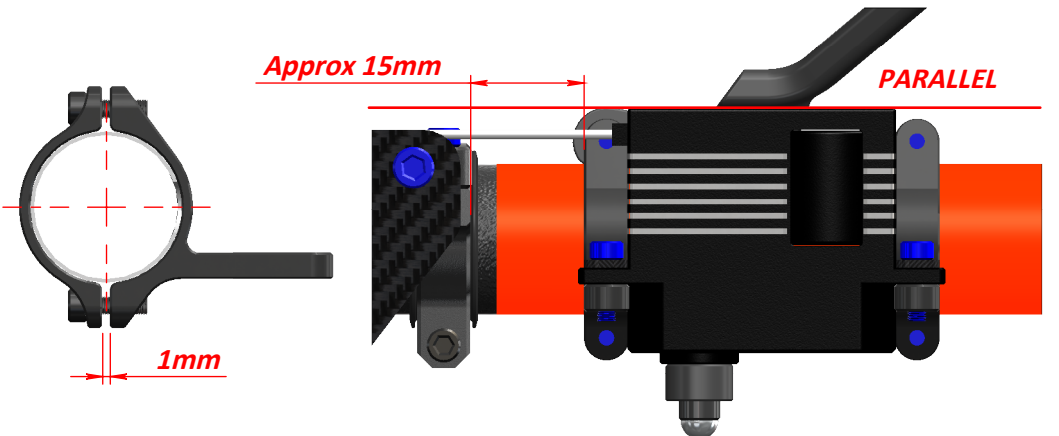

 Before installing the plastic links onto the threaded rod, be sure that you have waited for at least 12 hours and glue is fully cured.

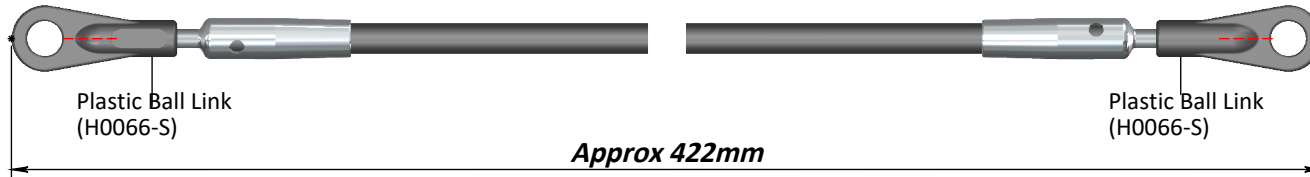

NOTE:
The carbon rod is slightly bent, generating a little preload against the carbon rod support

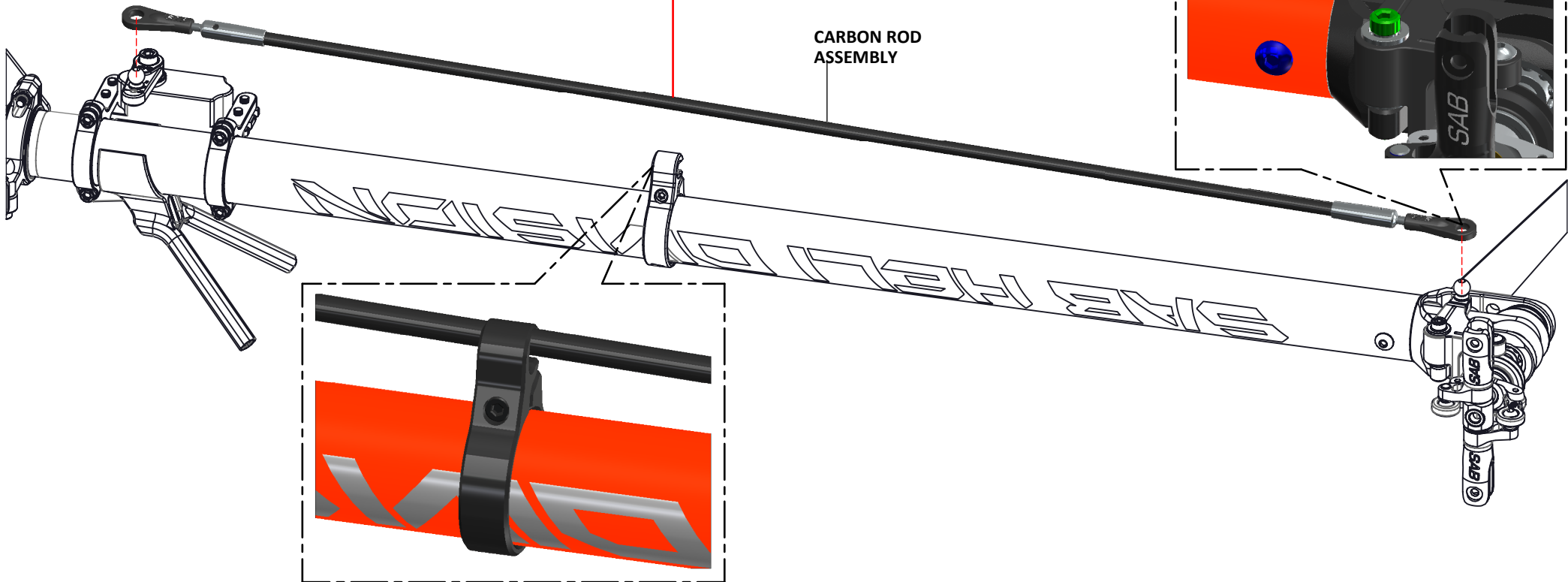

BOX 2, BAG FOR PAGE 25

ESC ASSEMBLY

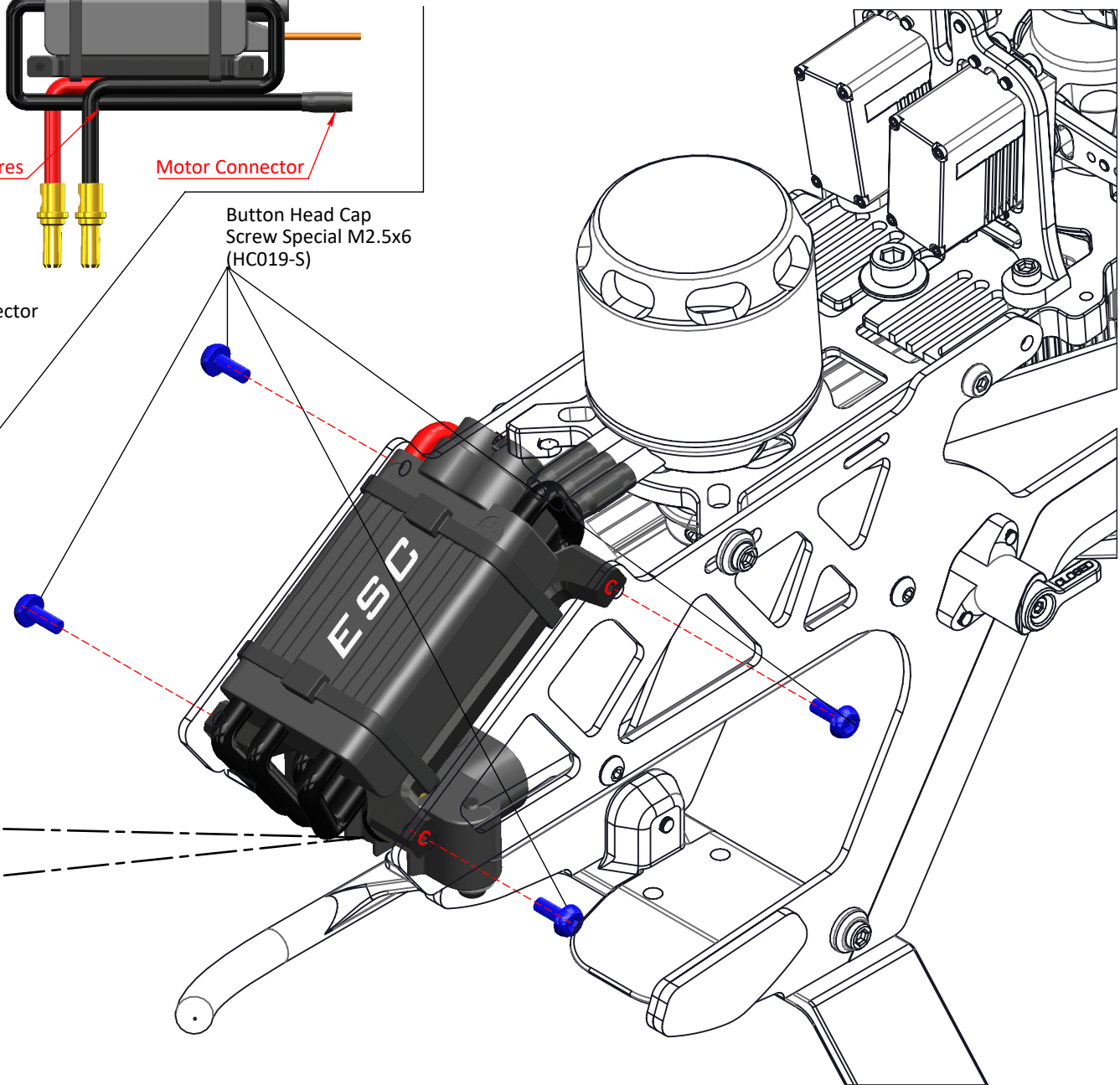
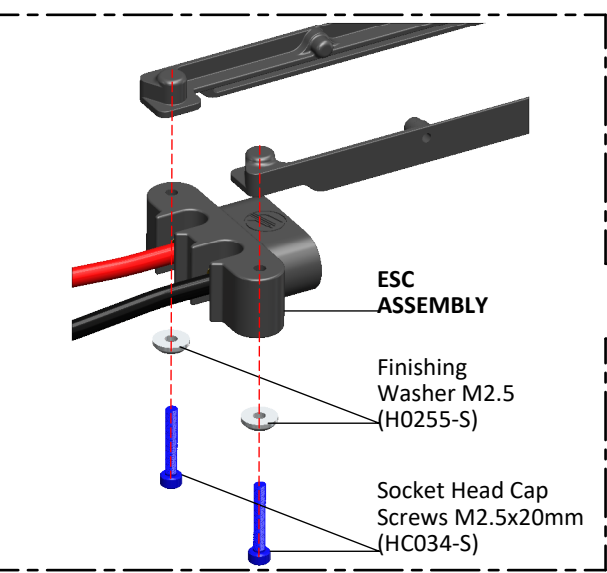
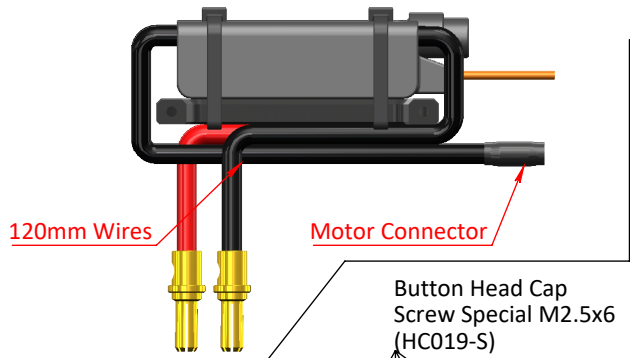
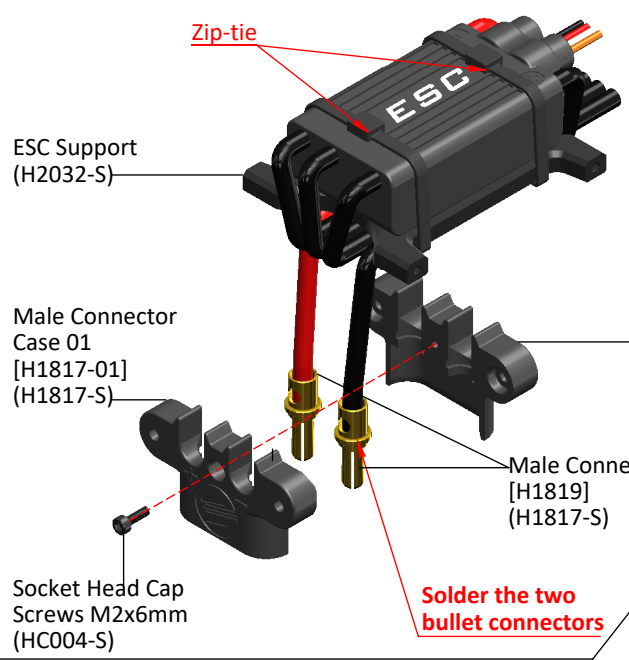

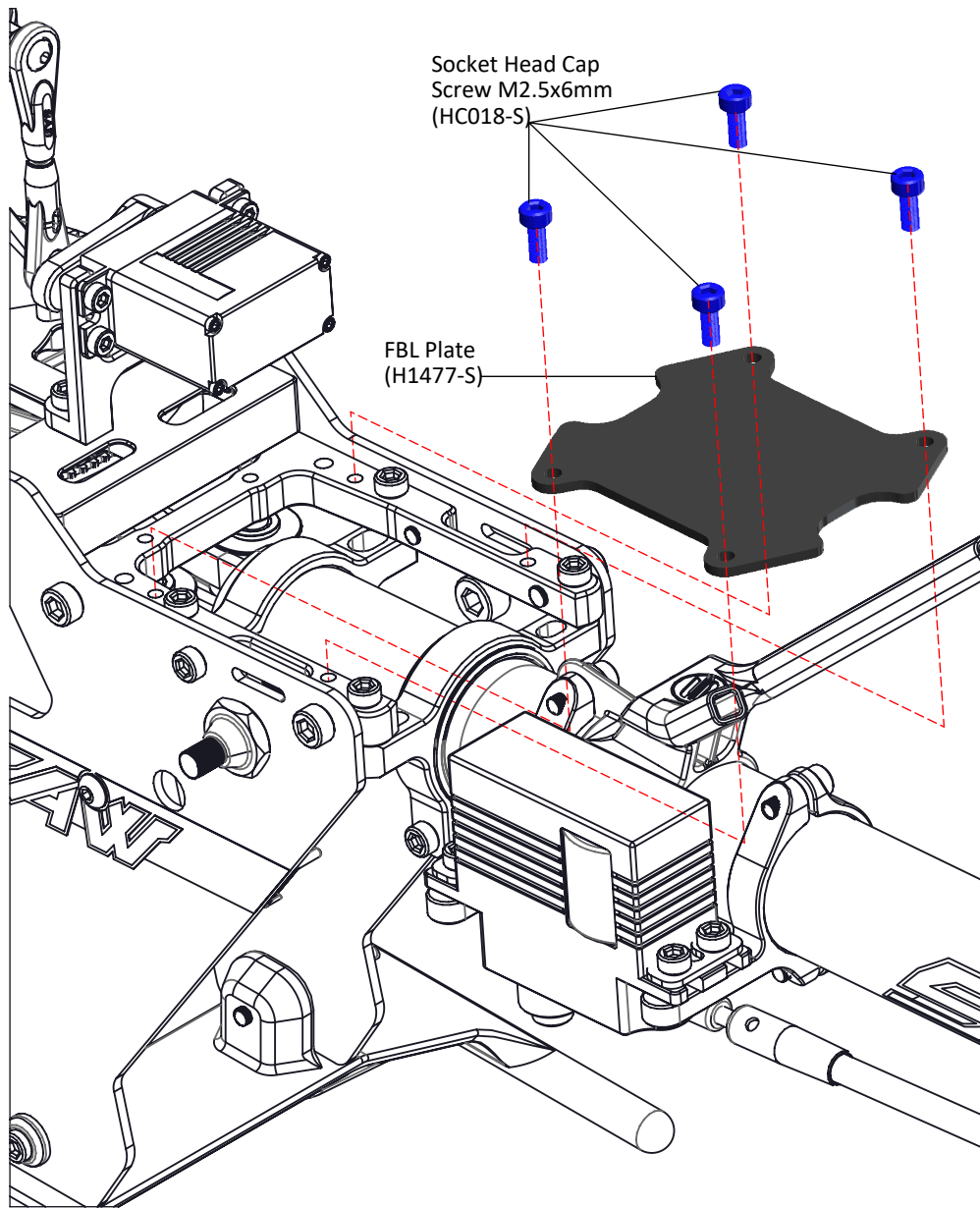

Socket Head Cap
Screw M2.5x6mm
(HC018-S)

FBL Plate
(H1477-S)

Note:
You can use a small piece of heat shrink tube to secure the antenna wires in place.

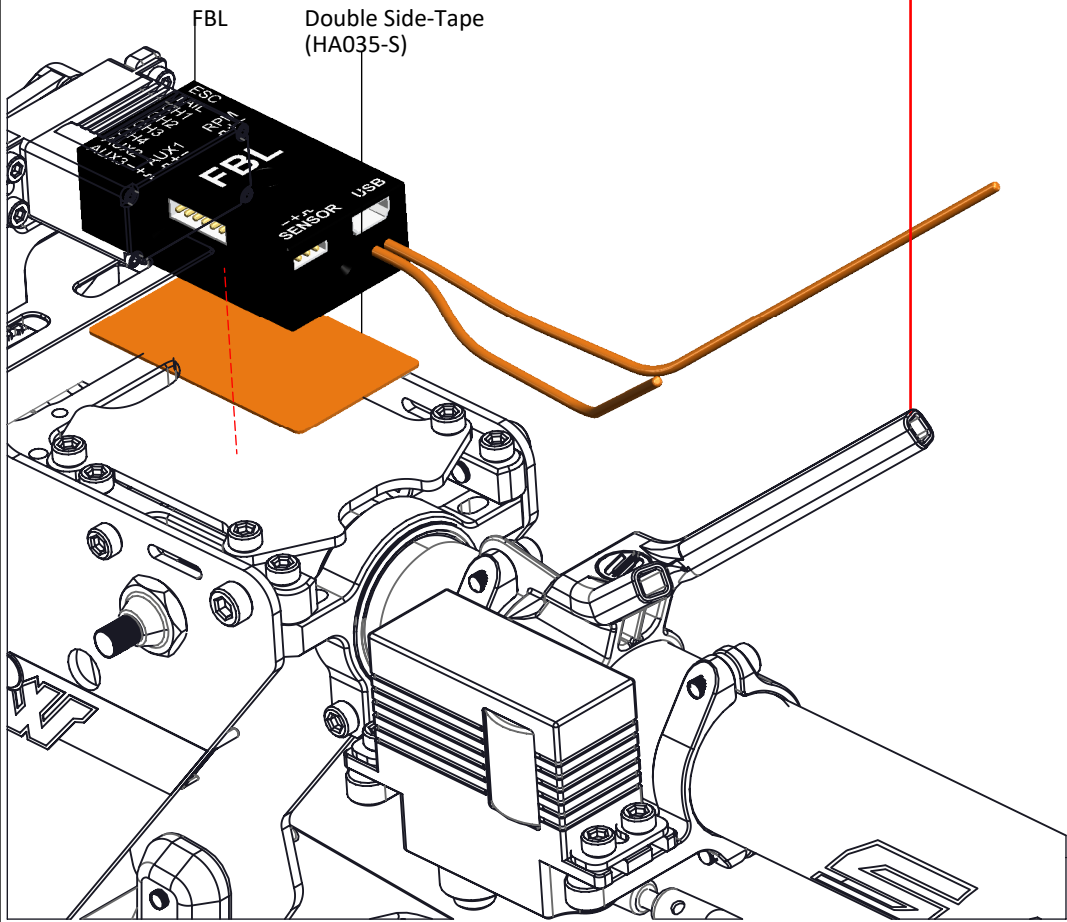

FBL

Double Side-Tape
(HA035-S)

BOX 2, BAG FOR PAGE 27

SUGGESTED WIRING

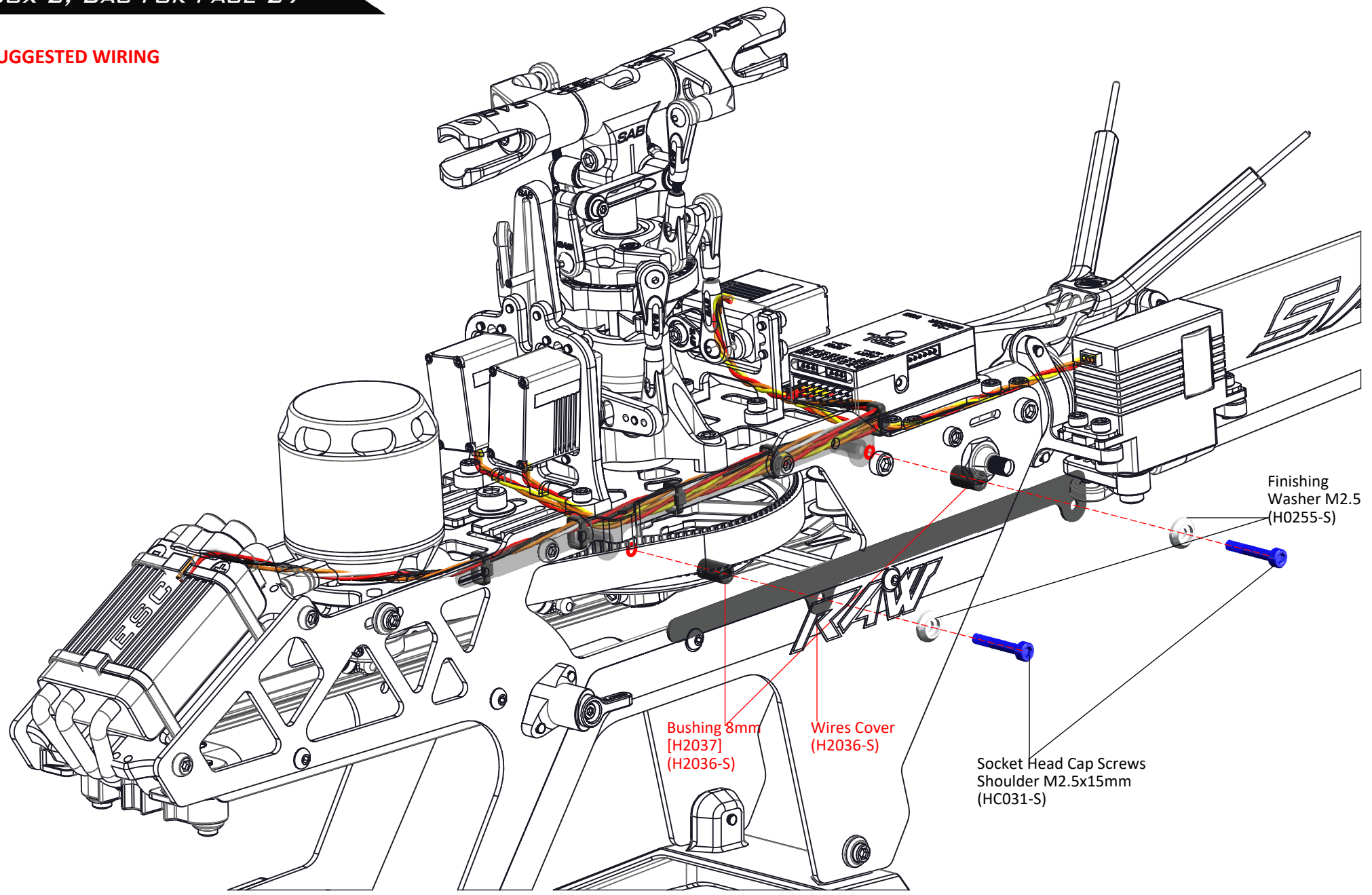

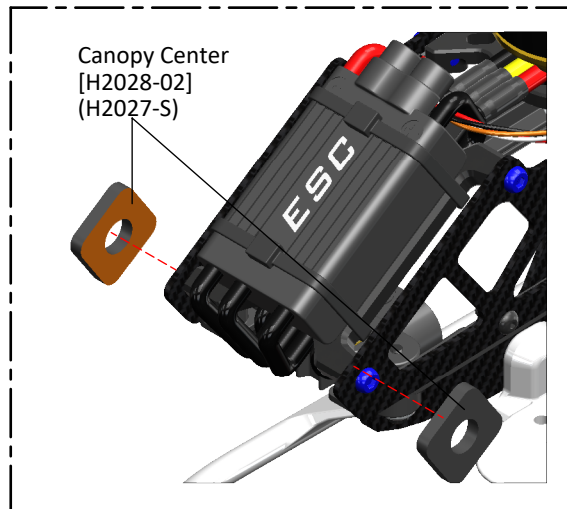
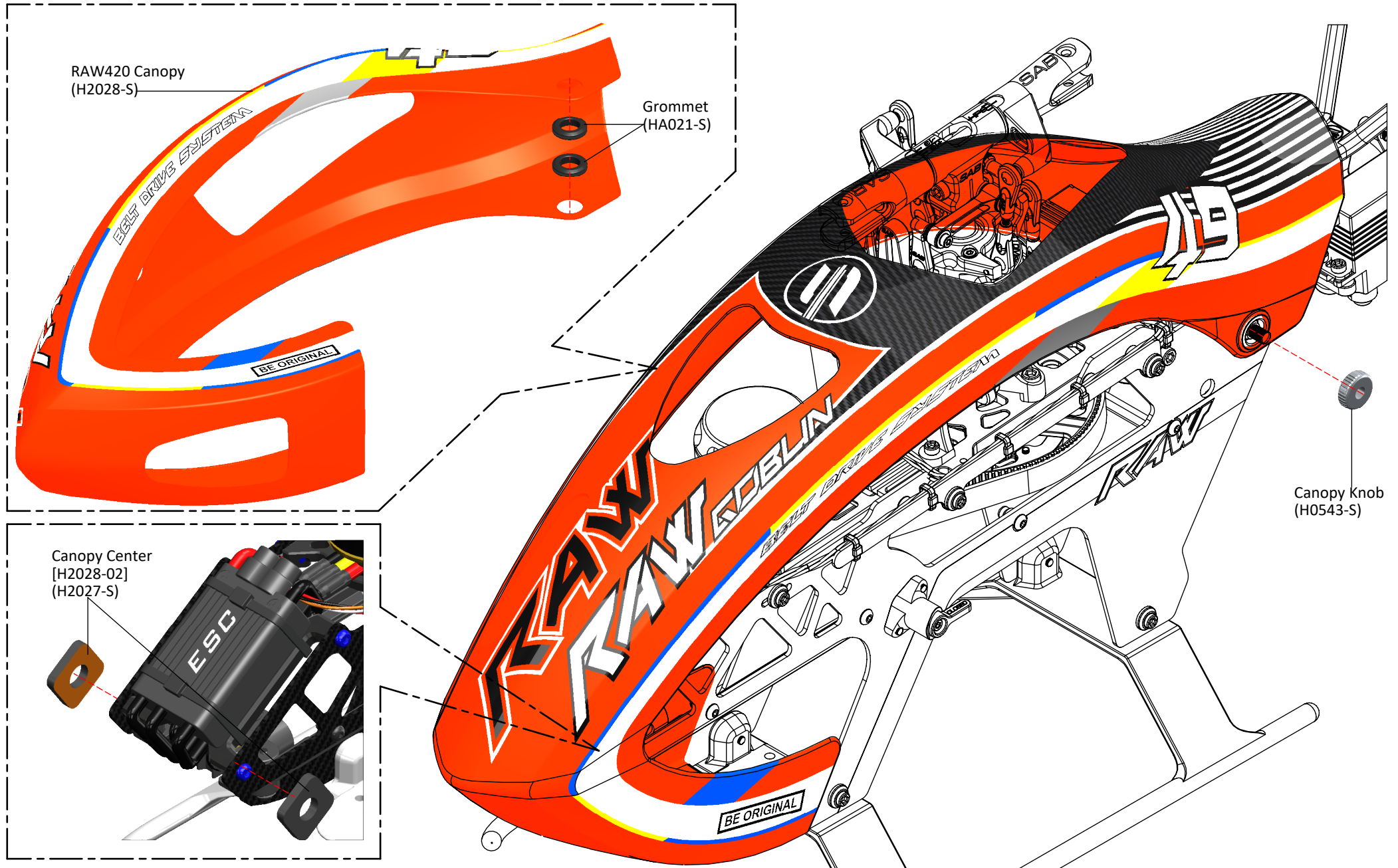

BOX 2, BAG FOR PAGE 29

! Before permanently mounting the battery on the battery tray, check the ideal position for the best center of gravity.



BATTERY ASSEMBLY

Use the included double sided tape to secure the battery to the tray. Use the Velcro Strap [HA023-S].

CAUTION: Please be extremely careful when soldering and installing the female connectors to the battery and installing them on the connector case. Lack of diligence and carefulness during this step could cause the connectors to make contact causing severe injury or death.

Solder the two bullet connectors

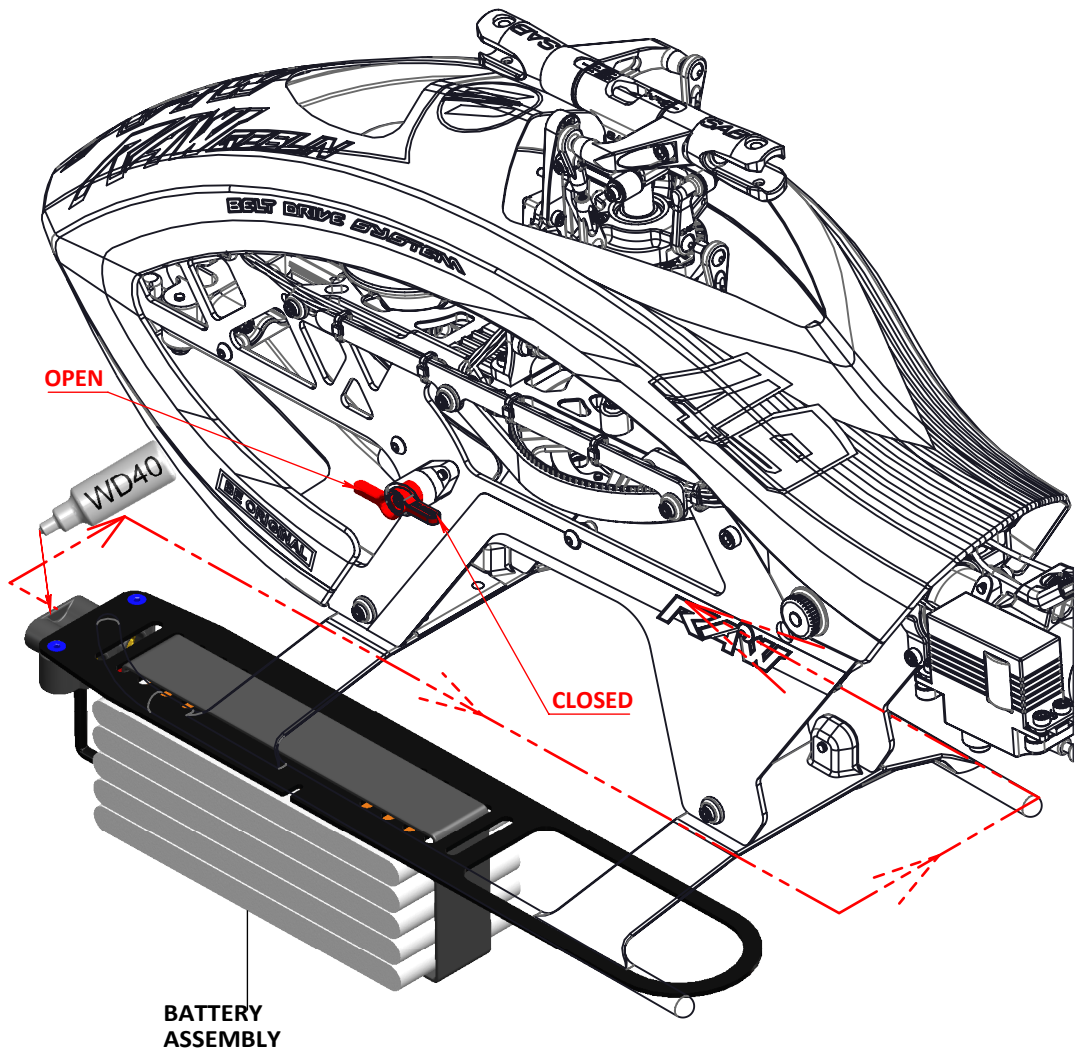
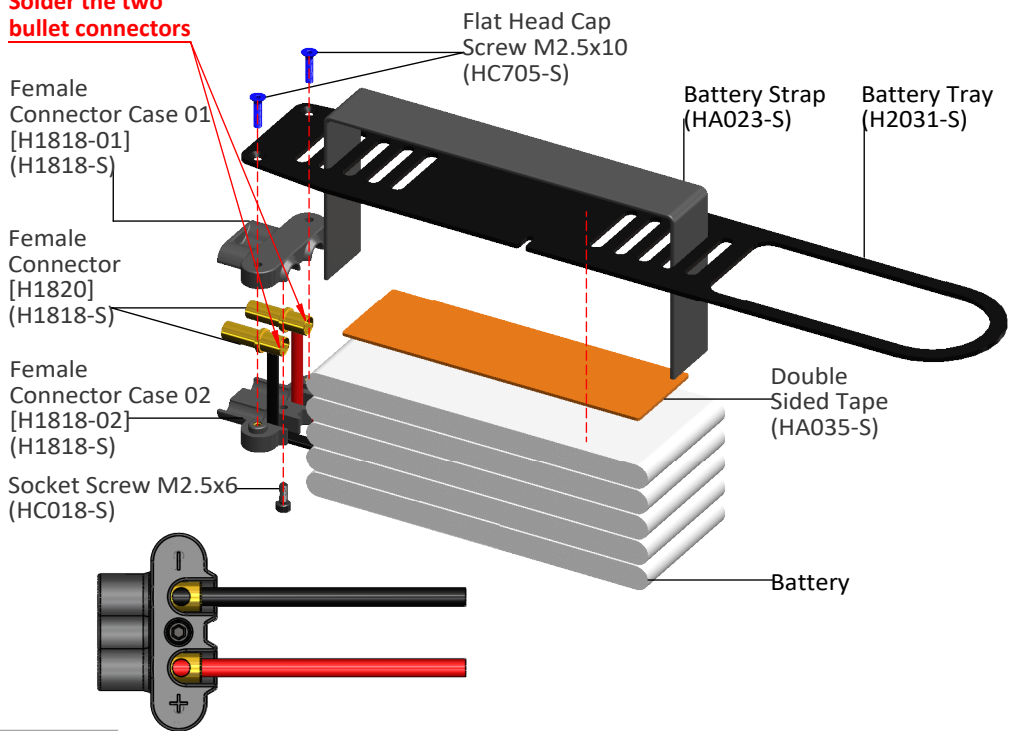

- * Lubricate the ESC and battery connectors with WD40. (If needed)
- * The locking lever has 2 positions, Open and Closed.
- * **The battery must be inserted with the lever in the closed position until a "click" is heard.**
- * To remove the battery, rotate the lever 180 degrees to the open position and pull the tray out. We highly recommend to immediately turn the lever back to the closed position to avoid forgetting to lock the battery on the next flight.
- * Always check that the battery is securely locked before each flight. You can check this by pulling on the battery, it should not come off if the lever is in the correct position and the battery tray is locked.



OPERATIONS BEFORE FLIGHT

- *Set up the remote control and the flybarless system with utmost care.
- *It is advisable to test the correct settings of the remote and flybarless system without main blades or tail blades fitted.
- *Check that all wiring is isolated from the carbon/aluminum parts. It is good practice to protect them at the points where they are at most risk.

! Be sure of the gear ratio, verifying carefully the motor pulley in use. The forces acting on the mechanics increase enormously with increase of rpm. Although the Goblin can fly at high rpm, for safety reasons we suggest to not exceed 3400rpm.

- *Fit the main blades and tail blades. (Figure.1 and Figure.2)
- *Please make sure the main blades are tight on the blade grips, you should be able to violently jerk the head in both directions and the blades should not fold. Failure to tighten the blades properly can result in a boom strike. To fold the blades for storage, it is advisable to loosen them.
- *Check the collective and cyclic pitch. For 3D flight, set about +/-13°.

*It is important to check the correct tracking of the main blades.
On the Goblin, in order to correct the tracking, adjust the main link rod. This is provided with a right/left thread system that allows continuous fine adjustments of the length of the control rod; for this adjustment it is not necessary to detach the ball link.

- *Confirm the canopy is secure prior to each flight.
- *Make sure that the battery locking pin is back in its resting position, blocking in correct way the battery tray.

! Perform the first flight at a low headspeed, 2200/2300 RPM.
After this first flight, do a general check of the helicopter. Verify that all screws are correctly tightened.

FIRST FLIGHT

- * Check that the connectors to the FBL / RX are all inserted correctly and secure.
- * We suggest initially using a tail gain setting in your FBL system between 40 to 50%.

! Check that the battery is securely locked and properly seated in the guides. The locking lever must always be oriented with the word closed facing upwards.

- * Perform the first flight at a low head speed, not exceeding 2200 rpm. After this first flight, do a general check of the helicopter. Verify that all the screws and bolts are correctly tightened.
- * It's very important to check the model over before every flight, check all bolts, screws, belts, ball links, etc.
- * If the model is making any strange noises check the blades balance.
If you want to fly high RPM (over 3000 rpm) you can replace the tail pulley with H1742-S 21T.

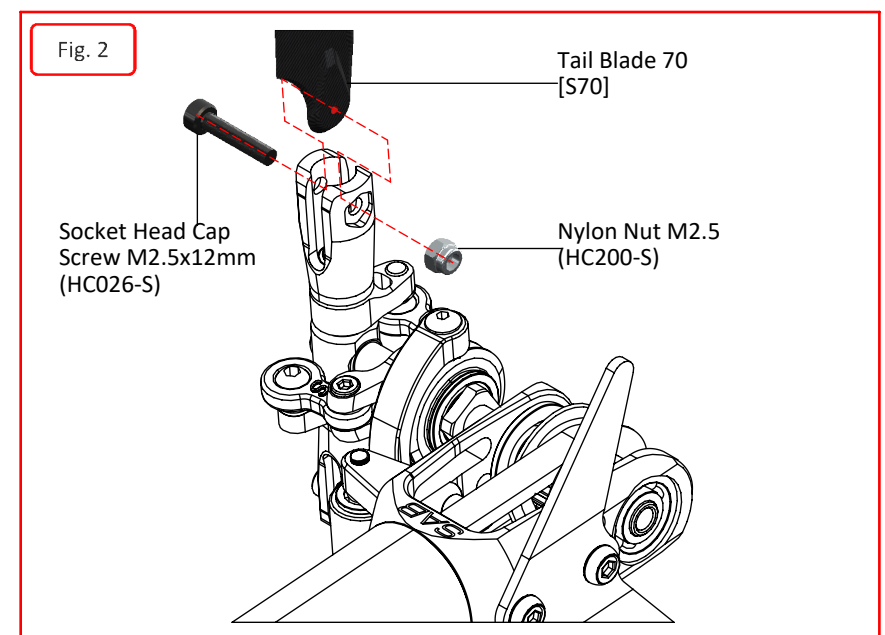
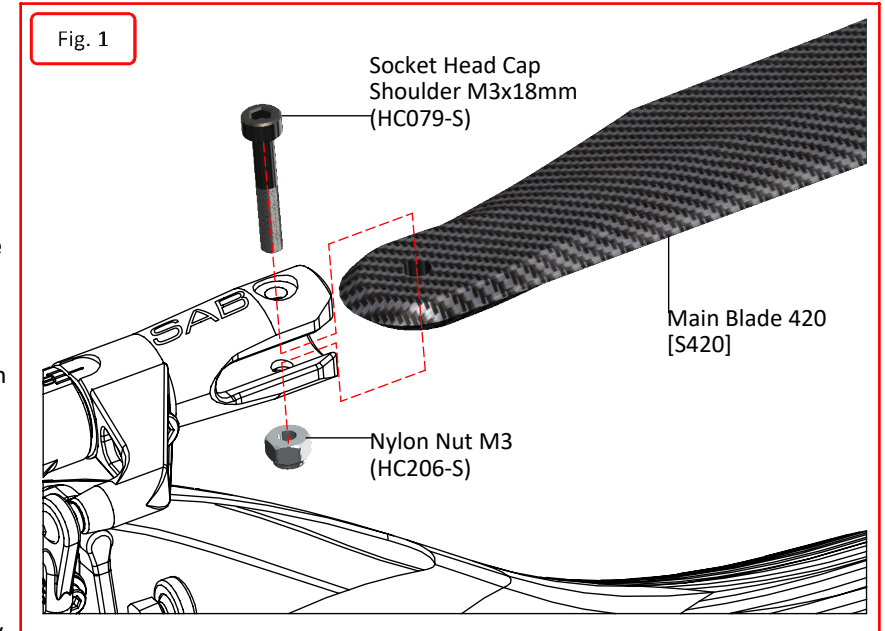

MAINTENANCE

Take a look at the red parts.

Check them frequently. All other parts are not particularly subject to wear.

The lifespan of these components varies according to the type of flying.

On average it is recommended to check these parts every 20 flights. In some instances, based on wear, these parts should be replaced every 100 flights.

Periodically lubricate the tail slider movement and its linkages as well as the swash plate movement and its linkages.

To ensure safety you should do a general inspection of the helicopter after each flight. You should check:

- Proper belt tension (engine belt and tail belt).
- Proper isolation of the wires from the carbon and aluminum parts.
- All screws and bolts remain tight.

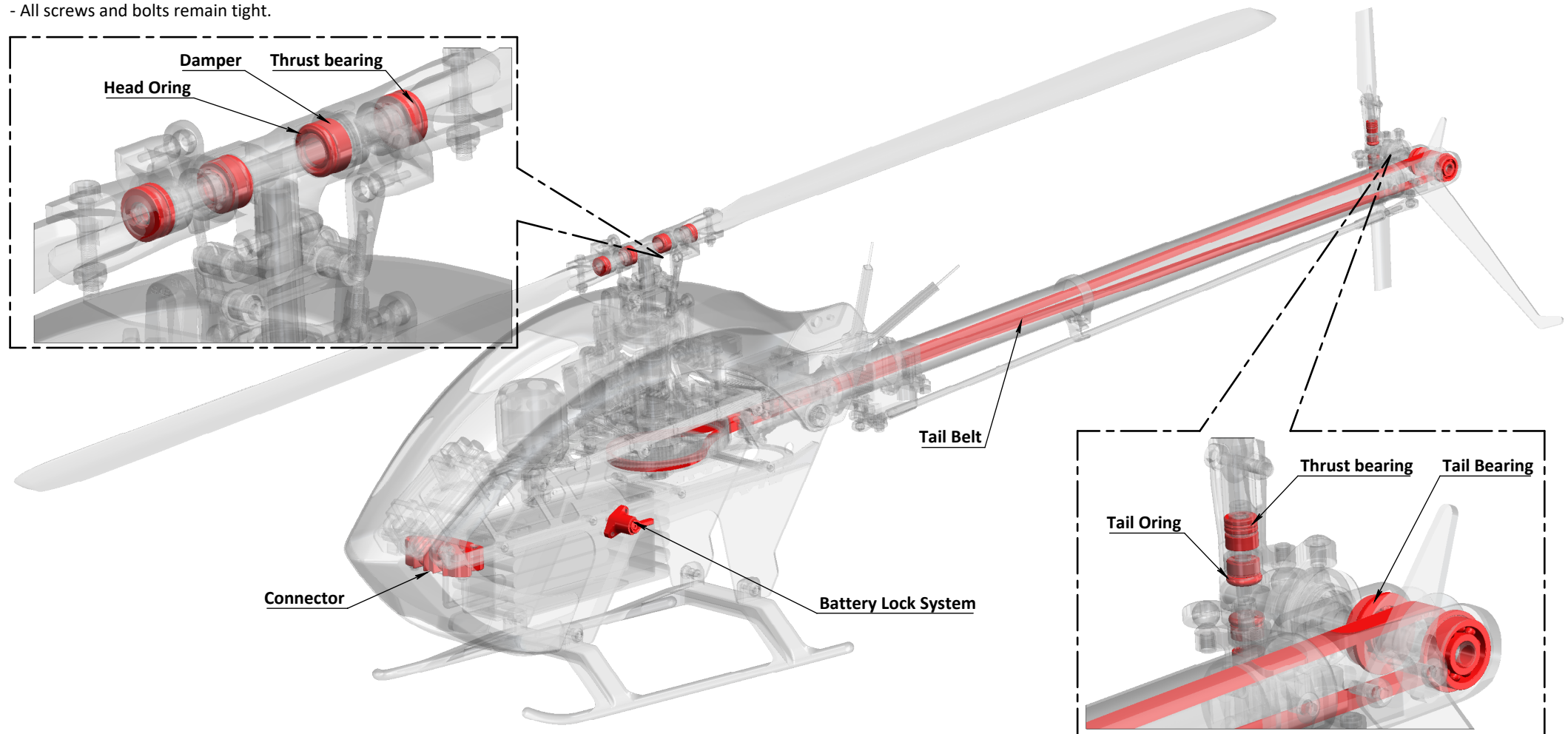

1 Check the dampening on the main and tail rotor to be the same as always.

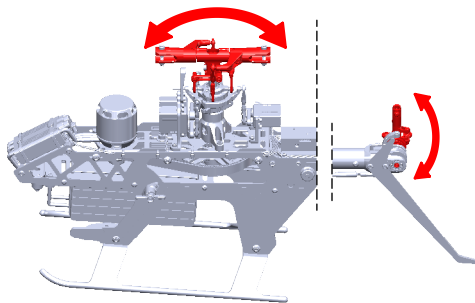

2 Tighten the main blades before flight.

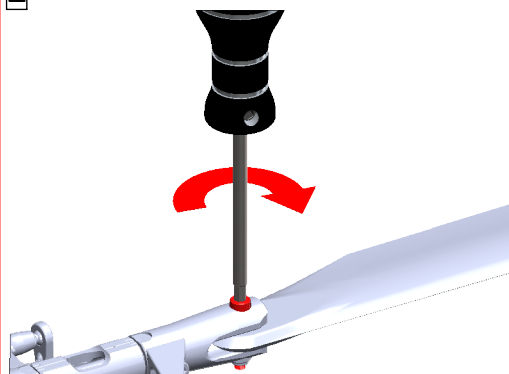

3 Check main hub screws M3
Ensure they are tight.

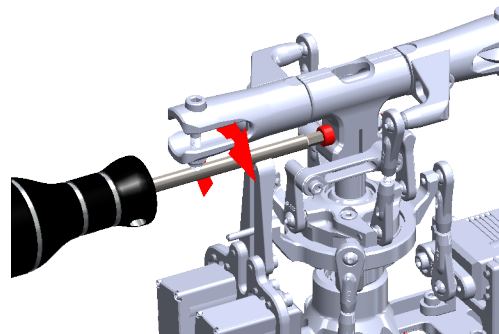

4 Check all power connectors
(Good mechanical connection).

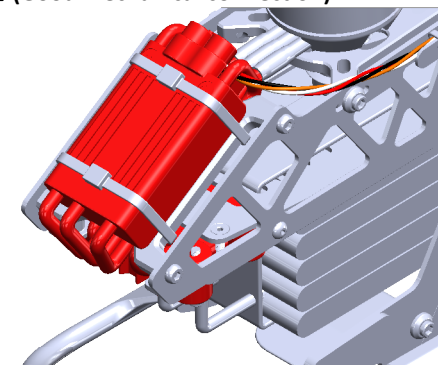

5 Check Tail belt tension.
The tension has to be tight.

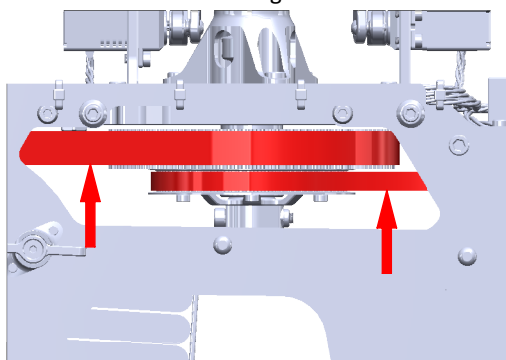

6 Check the 2 M3 Tail group screws.
Ensure they are tight.

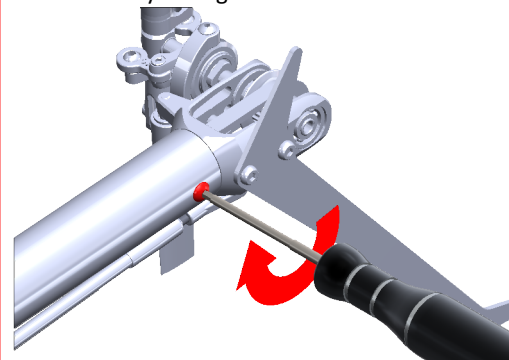

7 Check the Main Linkages & Servo Linkages

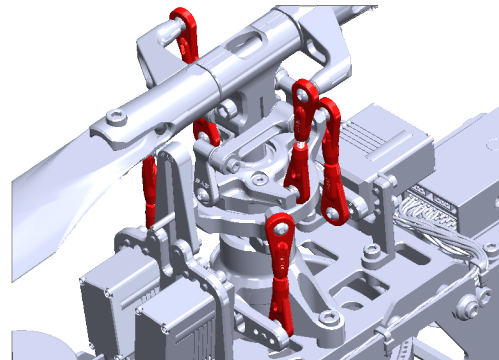

8 Check tail pulley set screw:
Ensure it is tight.
(It is suggested use a bit of Green Loctite.)

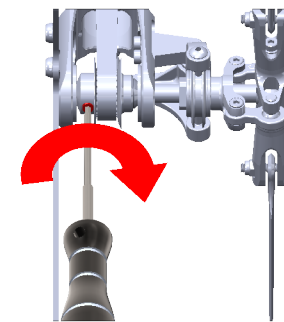

9 Check for vertical play of the main shaft.

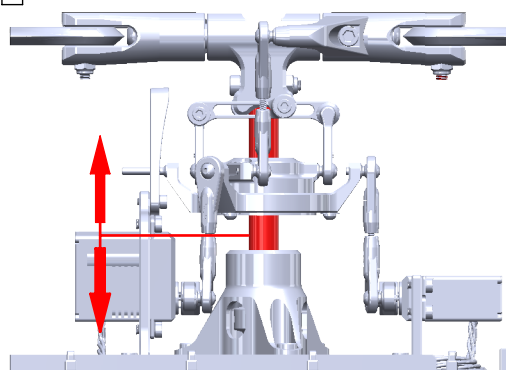

10 Check if the FBL-RX connectors are OK
(hot glue is recommended).

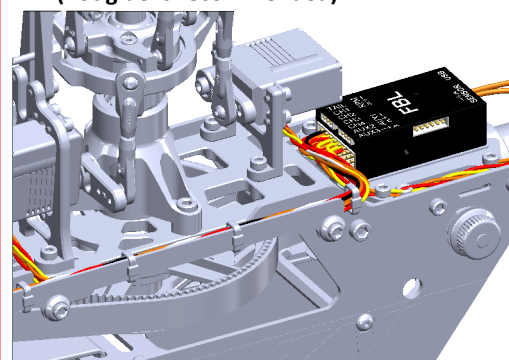

11 Check the M2.5 bell crank:
Bell crank movement must be smooth
and the screw locked.
(It is suggested use a bit of Green Loctite.)

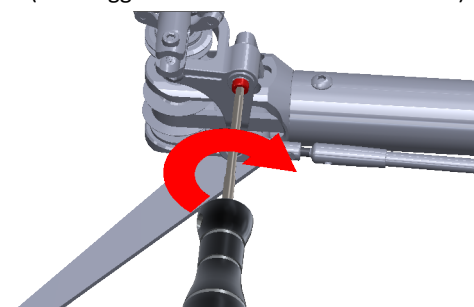











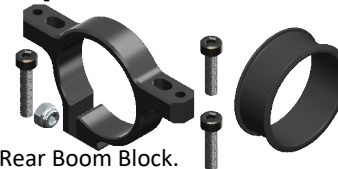

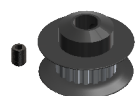
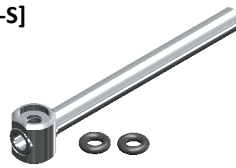

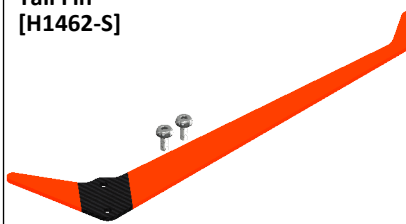

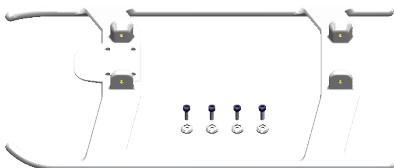
12 Be sure the following parts are properly lubricated

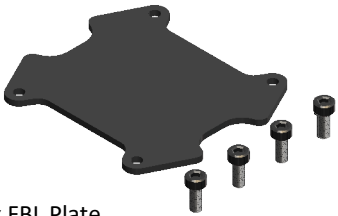
- *Main shaft/swashplate
- *Tail slider/tail shaft
- *Carbon rod/carbon rod support
- *All thrust bearings
- *All plastic balls connections

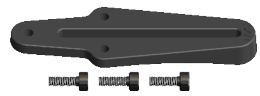

| | | | | |
|---|--|--|--|--|
| <p>Uniball M2 [H0064-S]</p>  <p>- 5 x Uniballs M2. - 5 x Uniball Spacers. - 5 x Head Cap Screws M2x8mm. - 5 x Head Cap Screws M2x6mm.</p> | <p>Uniball M3 [H0065-S]</p>  <p>- 5 x Uniball M3.</p> | <p>Plastic Ball Link [H0066-S]</p>  <p>- 10 x Plastic Ball Link.</p> | <p>Finishing Washer M2.5 [H0255-S]</p>  <p>- 10 x Finishing Washer M2.5.</p> | <p>Plastic Linkage [H0261-S]</p>  <p>- 2 x Plastic Linkage. - 2 x Spacers. - 2 x Head Cap Screws M2x6mm.</p> |
| <p>Plastic Ball Link M2 [H0403-S]</p>  <p>- 5 x Plastic Ball Link M2.</p> | <p>Motor Pulley 19T-24T [H0501-19-24-S]</p>  <p>- 1 x Motor Pulley Assembly 19T-24T. - 1 x Set Screw M3x6mm.</p> | <p>Main Spindle [H0508-S]</p>  <p>- 1 x Main Spindle. - 2 x Button Cap Screws M4x6mm.</p> | <p>Tail Spitch Slider [H0512-S]</p>  <p>- 1 x Tail Spitch Slider 01. - 1 x Tail Spitch Slider 02. - 1 x Tail Spitch Slider 03. - 2 x Flanged Bearing $\phi 7x \phi 11x2.5$.</p> | <p>Damper Set [H0518-S]</p>  <p>- 2 x Damper. - 2 x Oring 106, 1.78 x 6.75. - 2 x Shims $\phi 5x \phi 7x 0,1mm$. - 2 x Washer $\phi 7,5x \phi 10x0,5$. - 2 x Button Cap Screws M4x6mm.</p> |
| <p>Radius Plastic Arm [H0525-S]</p>  <p>- 2 x Radius Plastic Arm. - 2 x Washer $\phi 2,2x \phi 5x 0,3mm$.</p> | <p>Uniball M2 [H0538-S]</p>  <p>- 5 x Uniball M2.</p> | <p>Tail Spacers Set [H0540-S]</p>  <p>- 2 x Washer $\phi 3x \phi 4.75x0,5$. - 2 x Washer $\phi 4.5x \phi 5.9x0,5$. - 2 x Washer $\phi 2,1x \phi 4,5x0,5$. - 2 x Head Cap Screws M2x6mm. - 2 x Oring 2012, DI=2,9, S=1,78.</p> | <p>Canopy Position [H0542-S]</p>  <p>- 2 x Canopy Position. - 2 x Set Screws M4x20mm.</p> | <p>Canopy Knob [H0543-S]</p>  <p>- 2 x Canopy Knobs.</p> |
| <p>Servo Spacer [H0572-S]</p>  <p>- 4 x Servo Spacer.</p> | <p>Tail Belt Ilder [H0575-S]</p>  <p>- 1 x Tail Belt Ilder. - 2 x Flanged Bearing $\phi 2,5x \phi 6x2,6$.</p> | <p>Serial Number [H1212-S]</p>  <p>- 1 x Serial Number. - 1 x Flat Cap Screw M2.5x5mm.</p> | <p>Center Hub [H1445-S]</p>  <p>- 1 x Center Hub. - 1 x Head Shoulder Screw M3x16mm. - 1 x Nylon Nut M3.</p> | <p>Main Blade Grip [H1446-S]</p>  <p>- 2 x Main Blade Grip. - 4 x Bearing $\phi 5x \phi 10x4$. - 2 x Washer $\phi 7.5x \phi 10x0,5$. - 2 x Thrust Bearing $\phi 5x \phi 10x4$. - 2 x Button Head Screws M4x6mm.</p> |

| | | | | |
|--|--|--|--|--|
| <p>Boom Lock Support [H1452-S]</p>  <p>- 1 x Boom Lock Support.</p> | <p>Front Boom Lock [H1453-S]</p>  <p>- 1 x Front Boom Block. - 2 x Head Cap Screws M2.5x10mm - 1 x Head Cap Screw M2.5x12mm. - 1 x Nylon Nut M2.5.</p> | <p>Rear Boom Block [H1454-S]</p>  <p>- 1 x Rear Boom Block. - 1 x Rear Boom Block Ring. - 2 x Head Cap Screws M2.5x10mm. - 1 x Head Cap Screw M2.5x12mm. - 1 x Nylon Nut M2.5.</p> | <p>Tail Case [H1456-S]</p>  <p>- 1 x Tail Case. - 2 x Button Cap Screws M3x4mm. - 2 x Flanged Bearing $\varnothing 5x\varnothing 13x4$.</p> | <p>Bell Crank Base [H1457-S]</p>  <p>- 1 x Bell Crank Base. - 2 x Head Cap Screws M2x6mm.</p> |
| <p>Tail Pulley 20T [H1459-S]</p>  <p>- 1 x Tail Pulley 20T. - 1 x Set Screw M3x4mm.</p> | <p>Tail Shaft [H1460-S]</p>  <p>- 1 x Tail Shaft. - 1 x Tail Hub. - 2 x Tail Oring.</p> | <p>Tail Blade Grip [H1461-S]</p>  <p>- 2 x Tail Blade Grip. - 2 x Washer $\varnothing 4,5 x \varnothing 5,9x0,5$. - 2 x Washer $\varnothing 2,1 x \varnothing 4,5x0,5$. - 2 x Head Cap Screws M2x6mm. - 2 x Thrust Bearing $\varnothing 3 x \varnothing 6x2,8$. - 2 x Bearing $\varnothing 3 x \varnothing 7x3$. - 2 x Bearing $\varnothing 3 x \varnothing 6x2,5$.</p> | <p>Tail Fin [H1462-S]</p>  <p>- 1 x Tail Fin. - 2 x Button Cap Screws M2,5x6mm.</p> | <p>Carbon Rod Support [H1463-S]</p>  <p>- 1 x Carbon Rod Support. - 1 x Head Cap Screw M2x10mm.</p> |
| <p>Landing Gear [H1465-W-S]</p>  <p>- 1 x Landing Gear. - 4 x Finishing Washer M2.5. - 4 x Head Cap Screws M2.5x8mm.</p> | <p>Bearing Support [H1473-S]</p>  <p>- 1 x Bearing Support. - 1 x Bearing $\varnothing 8x\varnothing 16x5$. - 3 x Head Cap Screws M3x10mm.</p> | <p>Bearing Support [H1477-S]</p>  <p>- 1 x FBL Plate. - 4 x Head Cap Screws M2.5x6mm.</p> | <p>Swashplate [H1566-S]</p>  <p>- 7 x Uniball M2. - 1 x Reference Pin. - 1 x Swashplate ASM.</p> | <p>Main Shaft Block [H1567-S]</p>  <p>- 1 x Main Shaft Block. - 2 x Set Screws M4x4mm.</p> |
| <p>Front Servo Mount [H1568-S]</p>  <p>- 1 x Front Servo Mount. - 1 x Micro Servo Tool. - 2 x Head Cap Screws M2.5x8mm.</p> | <p>Rear Servo Mount [H1569-S]</p>  <p>- 1 x Rear Servo Mount. - 2 x Head Cap Screws M2.5x8mm.</p> | <p>Anti-rotation [H1687-S]</p>  <p>- 1 x Anti-Rotation. - 3 x Head Cap Screws M2x6mm.</p> | <p>Tail Spindle [H1689-S]</p>  <p>- 1 x Main Spindle. - 2 x Head Cap Screws M2x6mm. - 2 x Washer $\varnothing 2,1x\varnothing 4,5x0,5$.</p> | <p>Battery Lock [H1694-S]</p>  <p>- 1 x Shim. - 1 x Battery Lock Base. - 1 x Battery Lock CAM. - 1 x Battery Lock Pin. - 1 x Battery Lock Spring. - 1 x Head Cap Screw M2x6mm.</p> |

Blade Grip Arm
[H1701-S]



- 2 x Blade Grip Arm.
- 2 x Uniball M2.
- 2 x Head Cap Screws M3x6mm.

Bell Crank Clever
[H1702-S]



- 1 x Bushing.
- 2 x Tail Pin.
- 1 x Bell Crank Clever.
- 1 x Uniball M2.
- 1 x Head Cap Screw M2x5mm.
- 2 x Flanged Bearing $\phi 2.6 \times \phi 6 \times 2.6$.
- 1 x Head Cap Screw M2.5x18mm.

Tensioner Boom
[H1703-S]



- 1 x Clamp 01.
- 1 x Clamp 02.
- 1 x Clamp 03.
- 1 x Oring 3x0.8.
- 1 x Head Cap Screw M2.5x10mm.

Male Connector Case (ESC Side)
[H1817-S]

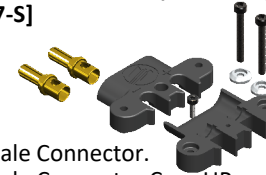

- 2 x Male Connector.
- 1 x Male Connector Case UP.
- 1 x Male Connector Case DOWN.
- 2 x Finishing Washer M2.5.
- 1 x Head Cap Screw M2x6mm.
- 2 x Head Cap Screws M2.5x20mm.

Female Connector Case (Battery Side)
[H1818-S]

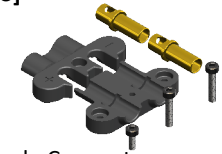

- 2 x Female Connector.
- 1 x Female Connector Case UP.
- 1 x Female Connector Case DOWN.
- 1 x Head Cap Screw M2.5x6mm.
- 2 x Head Cap Screws M2.5x12mm.

Main Plate
[H2023-S]

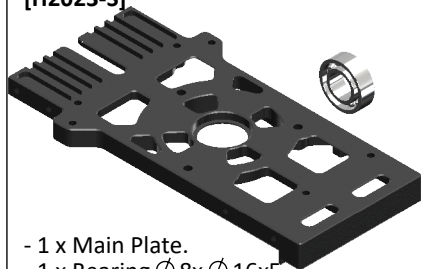

- 1 x Main Plate.
- 1 x Bearing $\phi 8 \times \phi 16 \times 5$.

Main Shaft
[H2024-S]

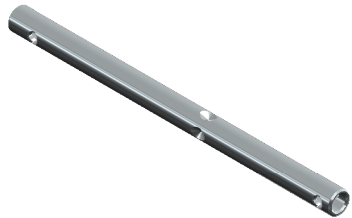

- 1 x Main Shaft.

Front Tail Pulley
[H2025-S]



- 1 x Front Tail Pulley ASM.
- 1 x Shoulder Cap Screw M3x16mm.
- 1 x Nylon Nut M3.

Motor Mount
[H2026-S]



- 1 x Motor Mount.
- 2 x Finishing Washer M2.5.
- 2 x Head Cap Screws M2.5x8mm.
- 1 x Head Cap Screw M4x15mm.
- 1 x Washer $\phi 4.3 \times \phi 11 \times 1$.

Main Frame
[H2027-S]



- 1 x Main Frame.
- 1 x Sticker.
- 1 x Foam 2mm.
- 1 x Foam 3mm.

Canopy
[H2028-S]



- 1 x Canopy.
- 2 x Canopy Gommel.

ESC Mount
[H2032-S]

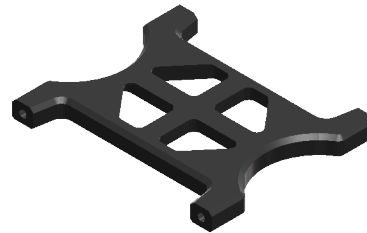

- 1 x ESC Plate.

Battery Guide
[H2029-S]

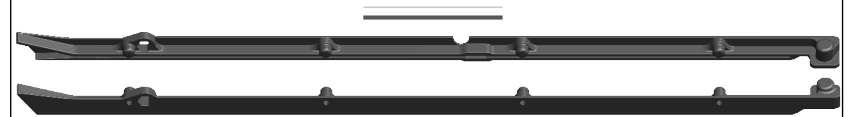

- 1 x SX Battery Guide.
- 1 x DX Battery Guide.
- 1 x HEX Spacer.

Battery Tray Connector
[H2030-S]

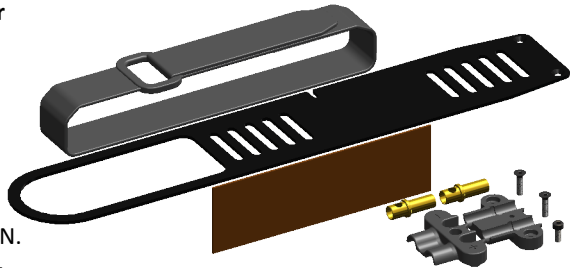

- 1 x Battery Tray.
- 1 x Battery Strap.
- 1 x Double Side Tape.
- 1 x Female Case UP.
- 1 x Female Case DOWN.
- 2 x Female Connector.
- 1 x Head Cap Screw M2.5x6mm.
- 2 x Flat Cap Screws M2.5x10mm.

Battery Tray
[H2031-S]

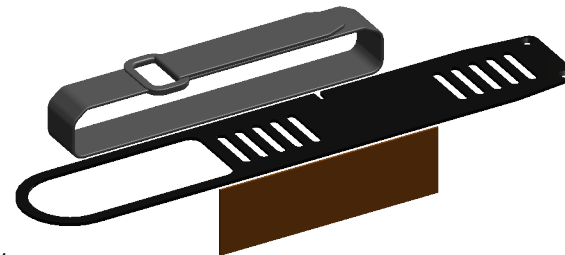















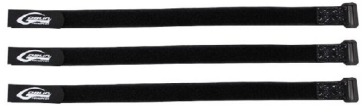

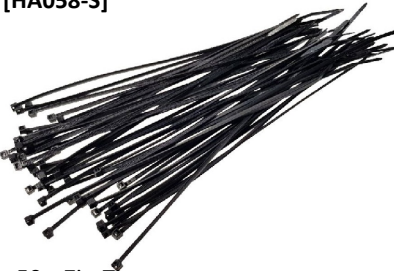
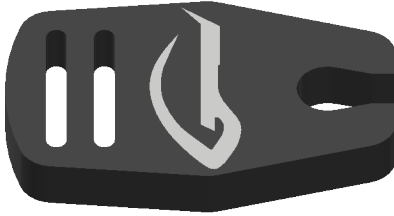
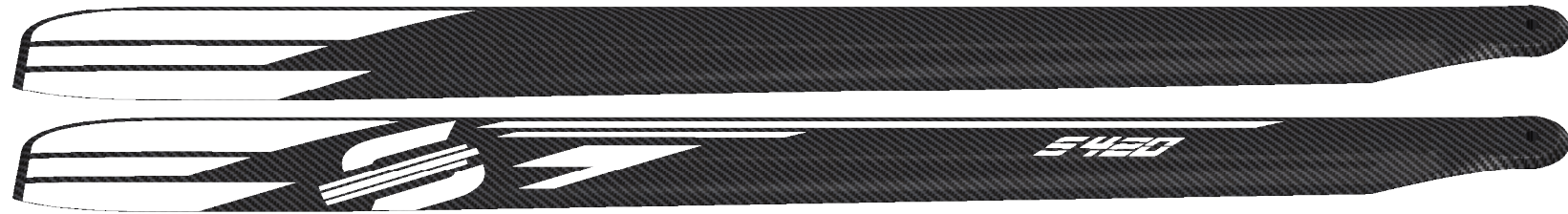























- 1 x Battery Tray.
- 1 x Battery Strap.
- 1 x Double Side Tape.











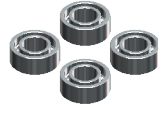
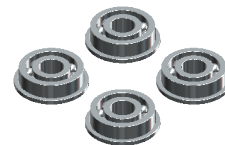



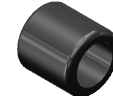

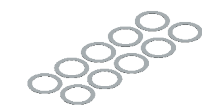
Tail Servo Mount
[H2034-S]

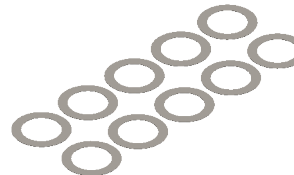

- 1 x Tail Servo Mount 01.
- 1 x Tail Servo Mount 02.
- 2 x Head Cap Screws M2.5x10mm.

| | | | | |
|---|--|---|---|---|
| <p>Antena Support [H2035-S]</p>  <p>- 1 x Antena Support.</p> | <p>Wire Cover [H2036-S]</p>  <p>- 1 x Wire Cover. - 2 x Bushing.</p> | <p>Radius Arm [H2040-S]</p>  <p>- 1 x Radius Arm. - 1 x Bushing. - 4 x Flanged Bearing $\phi 2x \phi 5x2.5$.</p> | <p>One Way Bearing Bushing [H2069-S]</p>  <p>- 1 x One Way Bearing Bushing.</p> | <p>Main Pulley [H2070-S]</p>  <p>- 1 x Main Pulley Assembly. - 2 x Shims $\phi 10.1x \phi 12x0,1$.</p> |
| <p>Tube Boom [H2128-S]</p>  <p>- 1 x RAW420 Orange Boom.</p> | <p>Battery Strap [HA023-S]</p>  <p>- 2 x Battery Strap.</p> | <p>Double Side Tape [HA035-S]</p>  <p>- 2 x Double Side Tape.</p> | <p>Zip-Tie [HA058-S]</p>  <p>- 50 x Zip-Tie.</p> | <p>Blade Holder [HA119-S]</p>  <p>- 1 x Blade Holder.</p> |
| <p>Main Blade 420 [S420]</p>  <p>- 1 x Main Blade S420.</p> | | | | <p>Tail Blade 70 [S70]</p>  <p>- 1 x Tail Blade S70.</p> |
| <p>[HC002-S]</p>  <p>- 10 x Head Cap Screws M2x5.</p> | <p>[HC004-S]</p>  <p>- 10 x Head Cap Screws M2x6.</p> | <p>[HC008-S]</p>  <p>- 10 x Head Cap Screws M2x8.</p> | <p>[HC010-S]</p>  <p>- 10 x Head Cap Screws M2x10.</p> | <p>[HC014-S]</p>  <p>- 10 x Head Cap Screws M2x12.</p> |

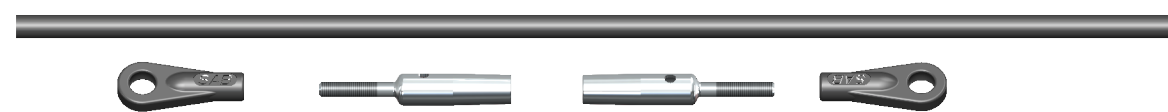
| | | | | |
|---|--|--|--|---|
| <p>[HC018-S]</p>  <p>- 10 x Head Cap Screws M2.5x6.</p> | <p>[HC019-S]</p>  <p>- 10 x Button Screws Special M2.5x6.</p> | <p>[HC020-S]</p>  <p>- 10 x Head Cap Screws M2.5x8.</p> | <p>[HC022-S]</p>  <p>- 10 x Head Cap Screws M2.5x10.</p> | <p>[HC026-S]</p>  <p>- 10 x Head Cap Screws M2.5x12.</p> |
| <p>[HC028-S]</p>  <p>- 10 x Head Cap Screws M2.5x15.</p> | <p>[HC031-S]</p>  <p>- 10 x Shoulder Cap Screws M2.5x15.</p> | <p>[HC032-S]</p>  <p>- 10 x Head Cap Screws M2.5x18.</p> | <p>[HC034-S]</p>  <p>- 10 x Head Cap Screws M2.5x20.</p> | <p>[HC038-S]</p>  <p>- 10 x Button Cap Screws M3x4.</p> |
| <p>[HC044-S]</p>  <p>- 10 x Head Cap Screws M3x5.</p> | <p>[HC056-S]</p>  <p>- 10 x Head Cap Screws M3x10.</p> | <p>[HC074-S]</p>  <p>- 2 x Shoulder Cap Screws M3x16. - 2 x Nylon Nut M3.</p> | <p>[HC079-S]</p>  <p>- 2 x Shoulder Cap Screws M3x18. - 2 x Nylon Nut M3.</p> | <p>[HC096-S]</p>  <p>- 10 x Button Cap Screws M4x6.</p> |
| <p>[HC105-S]</p>  <p>- 10 x Head Cap Screws M4x12.</p> | <p>[HC128-S]</p>  <p>- 10 x Flat Cap Screws M2.5x5.</p> | <p>[HC132-S]</p>  <p>- 10 x Flat Cap Screws M3x5.</p> | <p>[HC134-S]</p>  <p>- 10 x Flat Cap Screws M3x8.</p> | <p>[HC144-S]</p>  <p>- 10 x Set Screws M3x6.</p> |
| <p>[HC152-S]</p>  <p>- 10 x Set Screws M4x4.</p> | <p>[HC200-S]</p>  <p>- 10 x Nylon Nuts M2.5.</p> | <p>[HC206-S]</p>  <p>- 10 x Nylon Nuts M3.</p> | <p>[HC212-S]</p>  <p>- 10 x Nylon Nuts M4.</p> | <p>[HC242-S]</p>  <p>- 3 x Thread Rod M2.5x40.</p> |

| | | | | |
|---|--|--|---|--|
| <p>[HC400-S]</p>  <p>- 4 x Flanged Bearing ϕ 2.5x ϕ 6x2.6.</p> | <p>[HC411-S]</p>  <p>- 4 x Ball Bearing ϕ 5x ϕ 10x4.</p> | <p>[HC412-S]</p>  <p>- 4 x Flanged Bearing ϕ 5x ϕ 13x4.</p> | <p>[HC419-S]</p>  <p>- 2 x Bearing ϕ 8x ϕ 16x5.</p> | <p>[HC420-S]</p>  <p>- 2 x Ball Bearing ϕ 10x ϕ 15x4.</p> |
| <p>[HC435-S]</p>  <p>- 2 x Thrust Bearing ϕ 5x ϕ 10x4.</p> | <p>[HC442-S]</p>  <p>- 1 x One Way Bearing ϕ 10x ϕ 14x12.</p> | <p>[HC448-S]</p>  <p>- 2 x Thrust Bearing ϕ 3x ϕ 6x2.5.</p> | <p>[HC450-S]</p>  <p>- 10 x Shims ϕ 5x ϕ 7x0.1.</p> | <p>[HC453-S]</p>  <p>- 2 x Oring 1.78x2.9. - 2 x Oring 1.78x6.75.</p> |
| <p>[HC456-S]</p>  <p>- 4 x Flanged Bearing ϕ 2x ϕ 5x2.5.</p> | <p>[HC457-S]</p>  <p>- 4 x Ball Bearing ϕ 3x ϕ 6x2.5.</p> | <p>[HC458-S]</p>  <p>- 4 x Ball Bearing ϕ 3x ϕ 7x3.</p> | <p>[HC462-S]</p>  <p>- 10 x Shims ϕ 8x ϕ 12x0.1.</p> | <p>[HC500-S]</p>  <p>- 10 x Set Screws M3x4mm.</p> |
| <p>[HC464-S]</p>  <p>- 1 x Belt HTD 2M - 1250mm.</p> | | <p>[HC626-S]</p>  <p>- 10 x Set Screws M2x18mm.</p> | <p>[HC695-S]</p>  <p>- 1 x Belt HTD 2M - 330 - 09.</p> | |
| <p>[HC696-S]</p>  <p>- 2 x Plastic Ball Linkage. - 1 x Carbon Rod ϕ 2.5x ϕ 4x369mm. - 2 x Carbon Rod D4 Protect M2.5.</p> | | | <p>[HC697-S]</p>  <p>- 10 x Tapping Head Screws M2.5x6mm.</p> | <p>[HC705-S]</p>  <p>- 10 x Flat Head Screws M2.5x10mm.</p> |

Carefully check your model before each flight to ensure it is airworthy.

Consider flying only in areas dedicated to the use of model helicopters.

Check and inspect the flying area to ensure it is clear of people and obstacles.

Rotor blades can rotate at very high speeds! Be aware of the danger they pose.

Always keep the model at a safe distance from other pilots and spectators.

Avoid maneuvers with trajectories towards a crowd.

Always maintain a safe distance from the model.



GOBLIN RAW 420 COMPETITION

Release 1.0 - March 2024

WORLD DISTRIBUTION

www.goblin-helicopter.com

For sales inquiries, please email:

sales@goblin-helicopter.com

For info inquiries, please email:

support@goblin-helicopter.com

Attention: If you are a customer and have questions or need of assistance, please contact in a first time the Goblin retailer where you made the purchase.

EUROPEAN DISTRIBUTION

www.sabgroup.it

For sales inquiries, please email:

sale@sabgroup.it

For info inquiries, please email:

support@sabgroup.it

Attention: If you are a customer and have questions or need of assistance, please contact in a first time the Goblin retailer where you made the purchase.

WWW.GOBLIN-HELICOPTER.COM



SABGROUP



SAB HELI DIVISION